

This article was downloaded by:

On: 25 January 2011

Access details: *Access Details: Free Access*

Publisher *Taylor & Francis*

Informa Ltd Registered in England and Wales Registered Number: 1072954 Registered office: Mortimer House, 37-41 Mortimer Street, London W1T 3JH, UK



## Journal of Sulfur Chemistry

Publication details, including instructions for authors and subscription information:

<http://www.informaworld.com/smpp/title~content=t713926081>

### The chemistry of aqueous S(IV)-Fe-O<sub>2</sub> system: state of the art

Dave T. F. Kuo<sup>a</sup>; Donald W. Kirk<sup>a</sup>; Charles Q. Jia<sup>a</sup>

<sup>a</sup> Department of Chemical Engineering and Applied Chemistry, University of Toronto, Toronto, Ontario, Canada

**To cite this Article** Kuo, Dave T. F. , Kirk, Donald W. and Jia, Charles Q.(2006) 'The chemistry of aqueous S(IV)-Fe-O<sub>2</sub> system: state of the art', *Journal of Sulfur Chemistry*, 27: 5, 461 – 530

**To link to this Article:** DOI: 10.1080/17415990600945153

**URL:** <http://dx.doi.org/10.1080/17415990600945153>

PLEASE SCROLL DOWN FOR ARTICLE

Full terms and conditions of use: <http://www.informaworld.com/terms-and-conditions-of-access.pdf>

This article may be used for research, teaching and private study purposes. Any substantial or systematic reproduction, re-distribution, re-selling, loan or sub-licensing, systematic supply or distribution in any form to anyone is expressly forbidden.

The publisher does not give any warranty express or implied or make any representation that the contents will be complete or accurate or up to date. The accuracy of any instructions, formulae and drug doses should be independently verified with primary sources. The publisher shall not be liable for any loss, actions, claims, proceedings, demand or costs or damages whatsoever or howsoever caused arising directly or indirectly in connection with or arising out of the use of this material.

## REVIEW ARTICLE

# The chemistry of aqueous S(IV)-Fe-O<sub>2</sub> system: state of the art

DAVE T. F. KUO, DONALD W. KIRK and CHARLES Q. JIA\*

Department of Chemical Engineering and Applied Chemistry, University of Toronto,  
200 College Street, Toronto, Ontario, Canada

(Received 20 March 2006; in final form 4 August 2006)

The aqueous Fe-S(IV)-O<sub>2</sub> system is kinetically superior to pure O<sub>2</sub> in oxidizing inorganic (e.g., As(III) to As(V), S(IV) to S(VI)) or organic (e.g., phenol) compounds and can achieve E<sub>H</sub> levels (>1.3 V) that exceeds the O<sub>2</sub>-H<sub>2</sub>O couple. Fe-S(IV)-O<sub>2</sub> is important in various geochemical, biochemical, atmospheric, and industrial processes, and thus much effort has been devoted to understanding the mechanistic aspect of its redox chemistry. Despite the many advances made recently, Fe-S(IV)-O<sub>2</sub> redox chemistry has not been fully understood and elucidated. Clarification is needed on the redox chemistry of Fe-S(IV)-O<sub>2</sub>: from a mechanistic level (e.g. mode of catalysis, effects of ligand) to its relative importance in various natural processes (e.g., acid rain formation). We attempt to initiate some of these clarifications by: 1) critically examining experimental results, conclusions, and disagreements found in literature, 2) considering the Fe-S(IV)-O<sub>2</sub> system in the light of other relevant chemistries, 3) highlighting difficulties in experimental practice that can interfere with the chemistry of Fe-S(IV)-O<sub>2</sub>, and 4) discussing future research needs. This review ends with a large compilation of available thermodynamic properties (complex stability constants, E<sub>H</sub><sup>0</sup>) and kinetic data (rate expression, rate constants) relevant to Fe-S(IV)-O<sub>2</sub> system.

**Keywords:** Aqueous S(IV); Transition metal ions; Oxysulphur anions/radicals; Reaction mechanisms; Rate constants; Thermodynamics

## 1. Introduction

### 1.1 Historical studies on Me<sup>n+</sup>-S<sup>IV</sup>-O<sub>2</sub> and its applications

The Fe-S(IV)-O<sub>2</sub> system has been of great industrial and academic interests since the last century. In early 1900's, accelerated aqueous S(IV) oxidation by O<sub>2</sub> in the presence of trace transition metal ion, Me<sup>n+</sup>, was observed [1]. Catalytic oxidation of alcohols [2] and transition metal ions [3] by Me<sup>n+</sup>-S<sup>IV</sup>-O<sub>2</sub> were also found. As early as the 1920's, an air-SO<sub>2</sub> mixture has been used for producing ferric sulphate and sulphuric acid from ferrous sulphate [4]. Other important industrial processes involving Fe-S(IV)-O<sub>2</sub> (or the generic Me<sup>n+</sup>-S(IV)-O<sub>2</sub>) include treatment of mining effluents containing cyanide [5, 6], extraction of valuable metals from metal concentrates/smelter slag [7–10], flue gas desulphurization [11–14], and destruction of organic pollutants [15]. SO<sub>2</sub>-O<sub>2</sub> chemistry is also of great interest to food industry. S(IV) is

\*Corresponding author. Email: cqjia@chem-eng.toronto.edu

important for wine making [16], fruit preservation [17], or as dehydrated food additive [18] and textural altering agents [19, 20]. More recently, the possibility of using  $\text{SO}_2\text{-O}_2$  to oxidise As(III) to As(V) have also been investigated [21, 22]. After  $\text{SO}_2$  was identified as one of the major contributors to acid rain, atmospheric chemists suggested Fe-catalyzed S(IV) oxidation may be a major acid rain production pathway [23–25]. Since then, much effort has been devoted to understanding the mechanism and kinetics of  $\text{SO}_2$  oxidation in the atmosphere, where transitional metal ions, including Fe ions, are present at trace levels [26, 27]. Geochemists are also interested in the role  $\text{Me}^{n+}\text{-S(IV)-O}_2$  plays in geochemical cycles and interactions such as the potential coupling [28] of marine reduced sulphurs [29] and air-borne metal dust [30] and redox chemistry involving reduced species and transition metals in acid mine streams [31, 32] or natural lake system [33]. Recently, biochemical investigation of the S(IV) metabolism [34] and toxicity [35] in human bodies, and its ability to damage DNA [36, 37] have also started. In all cases, the presence of iron (or some other transition metal ions) is the essential catalyst that accelerates oxidation of S(IV).

## 1.2 Motivations of the review

Many recent studies have looked into the complex mechanistic nature of the Fe-S(IV)- $\text{O}_2$  (or  $\text{Me}^{n+}\text{-S(IV)-O}_2$ ) system in synthetic solutions [38–40] or environmental samples [6, 31, 41, 42]. They have employed various experimental techniques to test mechanistic hypotheses regarding different aspects of the system (e.g., predominant metal complexes [43, 44] and their relative catalytic importance [45], early time complexation and transformation dynamics [46, 47], inhibitory effects by organic species [48, 49], catalytic synergism [50, 51]), to probe the kinetics of particular reaction steps (e.g., radical-metal complex formation rate [52], intra-complex electron transfer rate [53], rate constants for elementary reactions involving oxysulphur radicals [54–56]), or to obtain thermodynamic properties of relevant species [57, 58]. Since the 1980's, reviews have tried to compile and condense the massive amount of data, hypotheses, models in literature and to elucidate the complex nature of  $\text{Me}^{n+}\text{-S(IV)-O}_2$  systems [26, 27, 59–66].

Although many explorations and explanations have been made regarding the Fe-S(IV)- $\text{O}_2$  system, much of its chemistry still remained unclear. Because many studies were conducted in simplified, synthetic settings, the behavioural sensitivity of Fe-S(IV)- $\text{O}_2$  towards the synergistic stress (i.e., due to uncharacterized organic/inorganic species, mineral precipitations, system parameter fluctuations such as T, pH, ionic strength, irradiation, etc) is poorly characterized and understood. This difficulty, together with the intrinsic complexity of the system, has driven some studies to adopt a pragmatic approach by establishing rate expressions with key system parameter dependencies that are empirically determined [67]. As a result, the relative importance of Fe-S(IV)- $\text{O}_2$  in a real context (e.g. atmospheric waters, surficial aquatic systems, engineered systems) still needs to be determined.

For example, the  $\text{O}_3\text{-S(IV)}$  redox pathway, which is significant at alkaline conditions, only accounts for  $\sim 10\text{--}30\%$  of the sulphate production in marine boundary layer aerosols [68]. The relative contributions by  $\text{H}_2\text{O}_2$ ,  $\bullet\text{OH}$ , or  $\text{Fe}^{\text{III}}$  (and  $\text{Me}^{n+}$ ) catalytic pathways are still unclear. In two other cloud/rain chemistry simulation studies [69, 70] where gas-water partitioning, physical transport, and extensive reaction networks (both aqueous and gaseous phase reactions) were considered, the role of Fe-catalyzed S(IV) oxidation remained ambiguous. The first study [69] reported  $\text{S(IV)}_{(\text{aq})}$  being converted to  $\text{S(VI)}_{(\text{aq})}$  at a rate of  $3.7 \times 10^{-9} \text{ mol}^{-1} \text{ s}^{-1}$  for a typical urban cloud/rainwater composition. Modeling results showed that about 8% of S(VI) were formed via  $\text{H}_2\text{O}_2$  (6%) or  $\text{O}_3$  (2%) pathway while the rest are oxidised primarily by  $\text{Br}_2^{\bullet-}$  (12%),  $\text{Cl}_2^{\bullet-}$  (17%), and  $\bullet\text{OH}$  (64%) radicals. It is well known that oxysulphur radicals

(SO<sub>X</sub><sup>•-</sup>, X = 2–5) and •OH can undergo interchange reaction with each other, and that Br<sub>2</sub><sup>•-</sup>, Cl<sub>2</sub><sup>•-</sup>, and •OH may all react with S(IV)<sub>(aq)</sub> (see C1 and C2 in Appendix C). Considering the huge network of radical reactions, it is thus very difficult to know how much of S(VI) formed is initiated by transition metal catalysis. The data presented in the second modeling study [70], however, indicated that atmospheric S(IV)<sub>(aq)</sub> was oxidised primarily by peroxy-species (H<sub>2</sub>O<sub>2</sub> and HNO<sub>4</sub>) depending on time of the day and their relative abundance. Likewise, the role of purely metal catalyzed S(IV) oxidation in colloidal suspension remains ambiguous when photo-induced oxidation also takes place [71].

It is generally accepted that the oxidation of Fe(II) to Fe(III) and the oxidation of S(IV) to S(VI) proceed much faster in an Fe-S(IV)-O<sub>2</sub> environment than in pure O<sub>2</sub>. However, there have been disagreements on both the kinetic and the mechanistic aspects of these reactions [43, 44, 64, 67, 72–75]. Although studies over the last ten years have greatly favoured the radical chain mechanism in explaining the redox behaviour in aqueous Fe-S(IV)-O<sub>2</sub> system [48, 54, 60, 66, 76]; refs within [26, 65], wide discrepancies on rate constants for specific reactions [54] (see also rate constant variability in C1, C2, C5 in Appendix C), disagreement on interpretation of the chain mechanism network, and contradictory observations are still found in literature. Furthermore, alternative mechanisms have not been conclusively invalidated. Many studies have quoted the radical chain mechanism, but very few have provided experimental evidence for its functioning in the particular case (e.g., [36, 37]). In other cases where the metal catalyst is bound by a relatively large ligands, alternative mechanisms may indeed prevail [77]. Lastly, experimental results from many investigations were ‘problematic’ due to interpretational bias or analytical negligence. All these disagreements, discrepancies, and deficiencies prompt for clarifications

This review attempts to initiate some of these clarifications by: 1) critically examining experimental results, conclusions, and disagreement found in literature, 2) considering the Fe-S(IV)-O<sub>2</sub> system in the light of other relevant chemistries, 3) highlighting difficulties in experimental practice that can interfere with the chemistry of Fe-S(IV)-O<sub>2</sub>, and 4) discussing future research needs. This review will end with compilations of available thermodynamic properties and kinetic data relevant to the chemistry of aqueous Fe-S(IV)-O<sub>2</sub> system.

## 2. Overview on general redox chemistry [78–81]

### 2.1 Thermodynamics of redox reaction

The general thermodynamic relationships for redox reaction are very well established. The spontaneity of a proposed redox reaction depends on the free energy for the reaction,  $\Delta G_{ET}$ , which can be related to the redox potential for the reaction  $\Delta E_H$ . A redox reaction with  $\Delta G_{ET} < 0$  will proceed spontaneously, but the rate of reaction is determined by the height of the activation energy barrier (see section 2.2). At thermodynamic equilibrium,  $\Delta G_{ET} = 0$ , and all redox couples present in the system should share the same  $pE$  or  $E_H$ .

### 2.2 Kinetics of redox reaction

**2.2.1 Dependence of rate on activation energy.** Redox reactions often have very favourable  $\Delta G_{ET}$  but they proceed rather slowly [79, 81]. Scheme 1 illustrates how oxidant (e<sup>-</sup> acceptor, ‘A’) and reductant (e<sup>-</sup> donor, ‘D’) get transformed to A<sup>-</sup> and D<sup>+</sup> through various energy states. The reactants first form a precursor-complex (PC) AD. A fraction of AD are energetic enough to overcome  $\Delta G_{ET}^{\ddagger}$ , the free energy of activation for the electron transfer, and

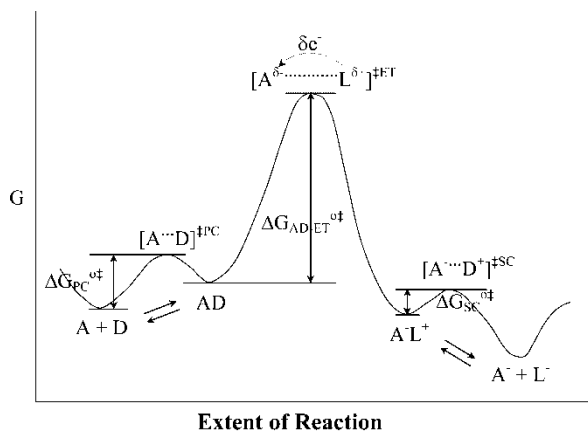

SCHEME 1 Generic energy diagram for electron transfer reaction.

form the highly unstable transition complex  $[A^{\delta-}\cdots L^{\delta+}]^{\ddagger ET}$ . Completion of electron transfer results in the formation successor complex (SC),  $A^-D^+$ , which dissociates to give the final products,  $A^-$  and  $D^+$ . Assuming  $\Delta G_{ET}^{o\ddagger}$  is much larger than  $\Delta G_{PC}^{o\ddagger}$  or  $\Delta G_{SC}^{o\ddagger}$ , the overall rate,  $r_{ET}$ , is then proportional to the concentration of the transition complex. Arrhenius equation and transition state theory allow  $r_{ET}$  and  $\Delta G_{ET}^{o\ddagger}$  to be mathematically related as [80]:

$$r_{ET} = \left(\frac{kT}{h}\right) \exp\left(\frac{-\Delta G_{rxn}^{o\ddagger}}{RT}\right) \{A\}\{D\} \approx \left(\frac{kT}{h}\right) \Delta G_{ET}^{o\ddagger} \{A\}\{D\} \quad (1)$$

The Marcus theory [78, 82] elaborates the meaning of  $\Delta G_{rxn}^{o\ddagger}$  for electron transfer reactions in more concrete terms. It is shown that the free energy of activation for electron transfer is determined by the standard free energy of the reaction  $\Delta G_{rxn}^o$  and the reorganization energy  $\lambda$ , which describes the energetic cost for electron to tunnel from optimal energy state of the  $e^-$  donor (i.e. bottom of 'energy well' of D) to that of the  $e^-$  acceptor (i.e. bottom of 'energy well' of A). Mathematically,  $\Delta G_{rxn}^{o\ddagger}$  is expressed as:

$$\Delta G_{rxn}^{o\ddagger} = \frac{(\Delta G_{rxn}^o + \lambda)^2}{4\lambda} \quad (2)$$

**2.2.2 Kinetics of oxidation by molecular oxygen [80].** Dissolved oxygen is known to exist predominantly as the ground state triplet oxygen (or dioxygen)  $^3O_2$ . The much more reactive singlet form,  $^1O_2$ , is much less abundant ( $\sim 10^{-14}$  to  $10^{-12}$  M  $^1O_2$  in natural waters [80]). Oxidation by triplet oxygen (or dioxygen) is often slow because reducing it to  $O_2^{\cdot-}$  is thermodynamically unfavourable ( $E_H^o(^3O_2/O_2^{\cdot-}) = -0.16$  V), while reduction of singlet oxygen is quite favourable ( $E_H^o(^1O_2/O_2^{\cdot-}) = 0.83$  V) (see B8 in Appendix B).  $^1O_2$  and other reactive oxidative species (ROS) (e.g.,  $H_2O_2$ ,  $\cdot OH$ ,  $HO_2^{\cdot}/O_2^{\cdot-}$ ) [83] mediate stepwise reduction of  $^3O_2$  [84], and thus the abundance of ROS essentially determines the overall rate of oxidation by molecular oxygen. In natural waters, ROS are primarily produced from the photolytic reactions of organic chromophores (e.g., dissolved organic matter DOM), hence their abundance is controlled by the intensity and duration of irradiation, the concentration of DOM, and the presence of oxidizable matters that serve as sinks for ROS.

**2.2.3 Enhanced reactivity of molecular oxygen by transition metal ions.** The presence of transition metal ions can improve redox reactivity of molecular oxygen (activation of

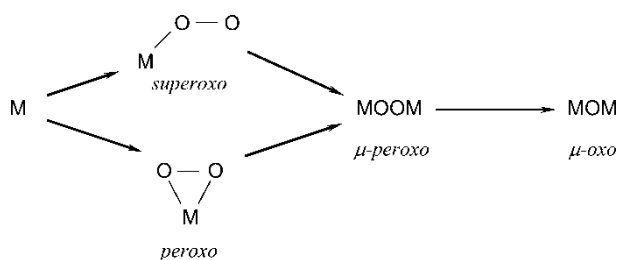

SCHEME 2 Structures of metal oxygen complexes.

oxygen) [85, 86] by forming metal-oxygen complexes such as a superoxo, peroxo and oxo structures (scheme 2) [87]. Dioxygen can also form an adduct with transition metal ions complexed by polydentates (i.e.  $\text{Me}^{n+}\text{-L}_{\text{poly}}$ ) via a superoxo configuration, with the unpaired electron resonated in the dioxygen structure [88–90]. Due to the stronger electron affinity of O than metal ions, electron density on the metal center is partially drawn/transferred to  $-\text{O}_2$  (i.e.  $\text{L}^{\prime}\text{-Me}^{(n+\delta)-\delta-}\text{O}_2^{\bullet}$ ), with the extent of transfer dependent on the nature of the polydentate ligand as well as its substituent functionalities [90]. Well known examples of  $\text{Fe-L}_{\text{poly}}$  capable of forming adduct with  ${}^3\text{O}_2$  are hemoglobin [88] and cytochrome [89], which are essentially Fe complexed by porphyrins. Both are actively involved in biochemical electron transfer reactions – the former as oxygen carrier, the latter as oxygenase [89, 91]. Qualitatively, the catalytic promotion of dioxygen redox activity in the presence of transition metal ions can be understood as a lowering in activation energy to the transition state (or  $E_{\text{H}}^{\circ}(\text{Me-O}_2/\text{O}_2^{\bullet-}) > E_{\text{H}}^{\circ}({}^3\text{O}_2/\text{O}_2^{\bullet-})$ ).

### 3. Speciations in aqueous Fe-S(IV)-O<sub>2</sub> system

#### 3.1 Dissolution of $\text{SO}_{2(\text{g})}$ and speciation of aqueous S(IV) oxides

$\text{SO}_{2(\text{g})}$  is very soluble in water when compared to  $\text{O}_{2(\text{g})}$  and other gases (see Appendix A). Dissolved S(IV) oxides exist mostly in three major forms,  $\text{SO}_2 \cdot \text{H}_2\text{O}$ ,  $\text{HSO}_3^-$  and  $\text{SO}_3^{2-}$ . Reactivity of aqueous S(IV) depends strongly on its speciation. Previous studies have suggested that  $\text{SO}_3^{2-}$  is about 20–40 times more reactive than  $\text{HSO}_3^-$ , which in turn is about 50 times more reactive than  $\text{SO}_2 \cdot \text{H}_2\text{O}$  [92–94]. The equilibrium distribution of dissolved S(IV) can be estimated according to the following equation:

$$[\text{S(IV)}] = [\text{SO}_2 \cdot \text{H}_2\text{O}](1 + K_{\text{a}1}\{\text{H}^+\}^{-1} + K_{\text{a}1}K_{\text{a}2}\{\text{H}^+\}^{-2}) \quad (3)$$

Where  $K_{\text{a}1}$  and  $K_{\text{a}2}$  are the acid dissociation constants for  $\text{SO}_2 \cdot \text{H}_2\text{O}$  and  $\text{HSO}_3^-$ , respectively. Acid dissociation constants for selected acids are tabulated in B1 and B2 in Appendix B. If the solution is in equilibrium with  $\text{SO}_{2(\text{g})}$ ,  $[\text{SO}_2 \cdot \text{H}_2\text{O}]$  is related to the partial pressure of  $\text{SO}_{2(\text{g})}$ ,  $P_{\text{SO}_2}$ , by Henry's Law constant (Appendix A).

Aqueous  $\text{HSO}_3^-$  has two tautomeric forms: bisulphite ion (form I,  $\text{HOSO}_2^-$ ) and sulphate ion (form II,  $\text{HSO}_3^-$ ) (see D.1 in Appendix D for structural configurations). More evidence is pointing towards bisulphite ion as the dominant species [26]. Furthermore, tautomeric form II can best explain the reactivity of  $\text{HSO}_3^-$  [63]. However, a recent *ab initio* study showed that the sulphate ion is more stable in both gaseous phase and aqueous phase by about 32–40  $\text{kJ mol}^{-1}$  [95]. In this review,  $\text{HSO}_3^-$  will mean a sum of both tautomeric forms. At high  $\text{HSO}_3^-$  concentration, dimerization can occur to produce disulphite ion,  $\text{S}_2\text{O}_5^{2-}$  ( $K_{\text{dimer}} = 7 \times 10^{-2} \text{ M}^{-1}$  [55]) [26, 96, 97]. However, disulphite is a minor form of S(IV) and accounts for no more than 3% of total S(IV) [26] and so it may be practically neglected [98].

### 3.2 Speciation of aqueous Fe ions

**3.2.1 Monomeric speciation of Fe in water.** Transitional metal ions, including Fe(II) and Fe(III) ions, do not freely exist in water. They are always coordinated with ligands. In the absence of other ligands, they are coordinated with H<sub>2</sub>O, the most abundant ligand in aqueous system. In the 'free' state, both Fe<sup>2+</sup> and Fe<sup>3+</sup> are complexed by six water molecules (i.e. Fe(H<sub>2</sub>O)<sub>6</sub><sup>2+</sup> and Fe(H<sub>2</sub>O)<sub>6</sub><sup>3+</sup>). The coordinated water molecules will be left out, and the aqua-complexes abbreviated as Fe<sup>2+</sup> or Fe<sup>3+</sup> hereafter.

Fe ions also hydrolyze water to form Fe-hydroxo complexes, i.e.:

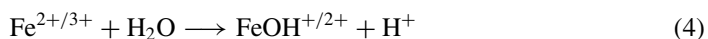

Thus addition of Fe(II) and Fe(III) increases system acidity [26]. The dominant Fe(II) form in water up to pH 7 is Fe(H<sub>2</sub>O)<sub>6</sub><sup>2+</sup> [99]. Speciation of Fe(III) in water, however, is more complicated as it can exist in several hydroxo forms, each of which dominates over different pH ranges. At elevated pH, the total Fe(III) concentration is constrained by precipitation. A list of Fe(II)- and Fe(III)-hydroxo complexes and their formation constants can be found in B3 and B5 in Appendix B.

**3.2.2 Hydrolytic polymerization of Fe(III) in water.** Fe(III) speciation is further complicated by the issue of hydrolytic polymerization at low pH [100]. Polymerization of Fe(III)-hydroxo complexes starts with dimerization and formation of small, multi-meric complexes (2–4 nm spherical structures;  $t \sim 10^2$ – $10^3$  s). These complexes will be converted into red cationic polymer. These polymers will go through a relatively slow aging phase, in which they are gradually converted to oxide phases through the removal of H from the entity ( $t \sim 10^6$  s). Upon maturity, polymeric oxide phase will precipitate out of the aqueous phase ( $t \sim 10^8$  s) [101–104], the speed of which depends on the nature and valencies of anions. Depending on the stage and time of aging, these polymer may range from  $10^3$  to  $10^4$  units [102, 105].

The polymerization mechanism essentially involves the bridging of Fe centers via oxygen species (OH<sup>-</sup>, O<sub>2</sub><sup>-</sup>) and the release of H<sup>+</sup> with more monomer addition. Thus, as Fe(III)-hydroxo polymers age, the OH<sup>-</sup>/Fe ratio increases (OH<sup>-</sup>/Fe ratio:  $\sim 1$  to 2 for fresh polymers;  $\sim 2.5$  for aging time < 1 d;  $\sim 2.8$  for > 10 d) and the system pH decreases. An ultimate lowest pH is expected as the polymerization reaches a limit [104, 105].

Hydrolytic polymerization is sensitive to pH, presence of other anion species, and Fe(III) concentrations. Addition of a small quantity of base to an Fe(III) solution containing NO<sub>3</sub><sup>-</sup>, Cl<sup>-</sup>, or SO<sub>3</sub><sup>2-</sup> can trigger rapid formation of hydrolytic polymer. Also, the formation of such precursor complex for Fe<sub>2</sub>(SO<sub>4</sub>)<sub>3</sub> is kinetically favoured at lower pH to the formation of Fe(III)-monovalent anionic complexes.

**3.2.3 Lability and reactivity of Fe-hydroxo complexes.** In general, Fe(III) becomes more reactive when it is coordinated with OH<sup>-</sup>. For instance, FeOH<sup>2+</sup> is about a few hundreds times more reactive than Fe<sup>3+</sup> [46, 107]. This has been attributed to the translabilization effect of the OH<sup>-</sup> ligand [26]. Furthermore, coordinated water molecules are more labile in the monohydroxo complex than in the hexaqua complex [46, 108], probably due to the stabilization effect of OH<sup>-</sup> on the Fe center. It is important to note, however, that metal ions in complexes with dimeric, trimeric, and multi-meric nuclei tend to react slower than those in monomeric complexes [100].

### 3.3 General consideration on the stability and speciation of Fe-S complexes

**3.3.1 Relative coordination strength of ligand.** The magnitude of the complex formation constant [79, 81],  $\beta$ , (most simplified case,  $\beta = \{\text{Me}^{n+}\text{L}^{w-}\}\{\text{Me}^{n+}\}^{-1}\{\text{L}^{w-}\}^{-1}$ ), for a complex is reflective of the strength of the metal-ligand(s) interaction. A high value for  $\beta$  implies the coordinated state is thermodynamically much preferred to the dissociated state, and thus the resulting complex is more stable. An example of this is Fe-EDTA complexes. Conversely, a low value for  $\beta$  would mean that the binding ligand is rather labile – it is equally ‘comfortable’ (or ‘uncomfortable’) in the dissociated or the coordinated form. An example of this is Fe<sup>II/III</sup>-Cl<sub>X</sub> complexes (log  $\beta$  roughly from 0.4 to 2).

The ability of a ligand to form a stable complex with a metal ion may not be inferred from its order in the spectrochemical series. For instance, in the series, H<sub>2</sub>O is known to have a higher order than oxalate (C<sub>2</sub>O<sub>4</sub><sup>2-</sup>), with OH<sup>-</sup> as the ‘weakest’ ligand of the three [109, 110]. Yet, Fe<sup>III</sup>OH<sup>2+</sup> (log  $\beta \sim 12$ ) is about three orders of magnitude more stable than Fe<sup>III</sup>C<sub>2</sub>O<sub>4</sub><sup>+</sup> (log  $\beta \sim 9$ ) (see B6 in Appendix B), and OH<sup>-</sup> exerts a greater stabilization effect than H<sub>2</sub>O on metal center (see section 3.2.3).

Although different mechanistic models have been offered to explain the catalytic redox activity in Fe-S(IV)-O<sub>2</sub> system, the critical role of Fe-S(IV) complexes being the rate determining species is unanimously recognized [26, 27, 59–66]. Thus it is important to understand how Fe-S complexes may be affected by the presence of other ligands.

**3.3.2 Relative stability of Fe-sulphato<sup>VI</sup> vs Fe-sulphito<sup>IV</sup> complexes.** Sulphite or related species can complex with metal ions in different ways. They can be bonded to the metal center through one single atom (S or O) or two atoms (S and O, or O and O). The O-bonded sulphito complexes could further undergo substitution, linkage isomerization and electron transfer reactions [43]. It has also been claimed that a more willing electron donating bonding-atom would form a more stable complex with the metal ion [44, 72]. Since S is less electronegative than O, it was expected that an S-bonded complex would be more stable than an O-bonded metal-sulphito complex. Another study [111] claimed that whether the metal-sulphito complex is S-bonded or O-bonded depended on the inertness of the metal complexes: an inert metal complex would form a S-bond with a sulphito group, whereas a labile complex would have a O-bond. Kraft and van Eldik [43, 73], however, stated that the O-bonded sulphito complexes were typically formed by nonlabile octahedral metal hydroxo species whereas the labile species would form S-bonded complexes. Various atmospheric groups have also suggested that pH has a critical role in controlling the structure of metal complexes and their relative distribution [112, 113].

Fe-sulphato complexes are generally much less stable than Fe-sulphito complexes. For instance, log  $\beta(\text{Fe}^{\text{II}}\text{SO}_3) \approx 8-9 > \log \beta(\text{Fe}^{\text{II}}\text{SO}_4) \approx 2$ ; log  $\beta(\text{Fe}^{\text{III}}\text{SO}_3^+) \approx 7 > \log \beta(\text{Fe}^{\text{III}}\text{SO}_4^+) \approx 3$ ; log  $\beta(\text{Fe}^{\text{III}}(\text{SO}_3)_2^-) \approx 18 > \log \beta(\text{Fe}^{\text{III}}(\text{SO}_4)_2^-) \approx 5.5$  (see B3 and B5 in Appendix B). If one may assume that the oxygen atoms bonded to the sulphito-S and the sulphato-S have more or less the same electron density around themselves, then the relative difference in Fe-sulphito and Fe-sulphato complexes must be rooted in the difference between sulphito-S and sulphato-S. Sulphato-S<sup>VI</sup>, being more deprived of electron density when compared to sulphito-S<sup>IV</sup>, should be less willing to associate with the electron-deprived Fe ion. Thus it may be argued that both sulphate and sulphite are bound to Fe<sup>II/III</sup> via a Fe-S linkage (rather than Fe-O) in a substantial fraction of Fe-S<sup>IV/VI</sup> complexes. Thus, it seems unlikely for Fe and sulphite/sulphate to interact through an O-Fe-O linkage, although Fe-S and O-Fe-S linkages still remain possible.



**3.3.3 Effects of  $H^+$  on the stability of Fe-S complexes.**  $H^+$  and  $OH^-$  are important species that will influence speciation chemistry of Fe-S complexes. By chemical intuition, association of  $Fe^{II/III}$  and a protonated ligand ( $H^+L^{w-}$ ) should be less favourable than the unprotonated ligand ( $L^{w-}$ ). Rearranging the complex formation equation to the form of equation (5) with the corresponding equilibrium constant  $\beta'$  (equation (6)). The relative stability of the two forms can be compared by considering  $\log\beta'$ , which can be derived from constants listed in B3–B6 in Appendix B.

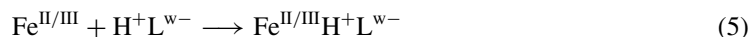

$$\beta' = \{Fe^{II/III}H^+L^{w-}\} \{Fe^{II/III}\}^{-1} \{H^+L^{w-}\}^{-1} \quad (6)$$

It can be shown that unprotonated ligands can indeed form more stable complexes with Fe ions ( $\log\beta'(Fe^{III}SO_3^+) \cong 7 > \log\beta'(Fe^{III}HSO_3^{2+}) \cong 2$ ;  $\log\beta'(Fe^{II}CO_3) \cong 5.5 > \log\beta'(Fe^{II}HCO_3^+) \cong 1.5$ ).

The effect of  $OH^-L^{w-}$  on complex stability is more ambiguous. Inconsistent trends are observed when comparing the formation constants between Fe-HL and Fe-OHL. It seems that in the presence of Fe(II), HL or OHL complexes are roughly equal in stability ( $\log\beta$  about the same for  $Fe^{II}HCO_3^+$  vs  $Fe^{II}(OH)(CO_3)^-$ , and for  $Fe^{II}HEDTA^-$  vs  $Fe^{II}OHEDTA^{3-}$ ). However, for Fe(III) complexes,  $OH^-$  does impose a pronounced stabilization effect ( $\log\beta(Fe^{III}OH(SO_3)) \cong 19 > \log\beta(Fe^{III}HSO_3^{2+}) \cong 9$ ;  $\log\beta(Fe^{III}OHEDTA^{2-}) \cong 34 > \log\beta(Fe^{III}HEDTA) \cong 29$ ).

### 3.4 Formation and dissociation kinetics of Fe-sulphito complexes

The forward and reverse rate constants for the formation/dissociation reactions of some Fe(II/III) complexes are listed in C8 in Appendix C. The intrinsic rates for other equilibrium reactions such as dissociation/formation of  $H_2O$  or  $HSO_3^-$  are also listed as references.

## 4. Reactions in aqueous Fe-S(IV)- $O_2$ system

In strict terms, Fe-S(IV)- $O_2$  is not a catalytic system because all three species are chemically transformed. The ‘catalytic’ nature of the system refers to its capability to accelerate, under appropriate chemical conditions, the oxidation rate by  $O_2$ . This rate enhancement feature is caused by the co-participation of the oxidative Fe(III) and reductive S(IV) in a series of redox reactions. The ultimate electron acceptor in the system is  $O_2$ , though other species such as Fe(III) may also be reduced. Energetically, the Fe(III)-S(IV) interaction in the presence of  $O_2$  leads to a lower activation barrier for electron transfer reactions. The oxidation speed of molecular oxygen is greatly reduced when either Fe(III) or S(IV) is absent. For instance, Fe(II) exposed to molecular oxygen at pH 4 has a half-life of almost a year [81], while S(IV) exposed to pure oxygen is fairly stable until transition metals are added [114].

The overall redox behaviour of the system depends highly upon the relative dominance of the oxidative species (i.e.  $O_2$ , Fe(III)) versus that of the reductive ones (i.e. Fe(II), S(IV)). In natural or engineered systems, the presence of other oxidative and reductive chemicals will also influence the redox behaviour of Fe-S(IV)- $O_2$ . Qualitatively, oxidation of Fe(II), S(IV), or other reductants will occur when the oxidative species are controlling. Under reducing condition, or insufficient  $O_2$  supply, S(IV) oxidation will stop and Fe(III) reduction may occur. The  $[Fe(III)]/[Fe(II)]$  ratio, the initial ratio  $[Fe]_{Tot}/[S(IV)]$  [66], as well as %  $SO_2$  relative to  $O_2$  [4, 39, 115] have been reported to dictate the system between its ‘oxidative’ and ‘reductive’ modes.

#### 4.1 Oxidation of chemical species by Fe-S(IV)-O<sub>2</sub>

SO<sub>2(g)</sub>-O<sub>2(g)</sub> becomes a powerful and efficient oxidant in the presence of transitional metal ions such as Fe, Mn, Cu, Ni and Co [50, 64, 116, 117]. The oxidation of oxidizing Ni(II) and cyanide has been reported [5]. In another study, the oxidation of As(III) to As(V) was found to be enhanced by a 2% SO<sub>2(g)</sub> in O<sub>2(g)</sub> mixture in the presence of Fe(III) at pH 0.5–2 [22]. Complete degradation of phenol to CO<sub>2</sub> has also been observed in Cu(II)-SO<sub>3</sub><sup>2-</sup>-O<sub>2</sub> at industrial conditions (80–110 °C, P<sub>O<sub>2</sub></sub> = 1.5–4.5 atm) [15]. Similarly, accelerated Fe(II) oxidation [4, 39, 74, 115, 118] and S(IV) oxidation [67, 73, 74, 114, 119] were also reported in various batch or semi-batch Me<sup>n+</sup>-S(IV)-O<sub>2</sub> systems.

Regardless of the transformation direction, S(IV) is often oxidised. Sulphates (HSO<sub>4</sub><sup>-</sup>, SO<sub>4</sub><sup>2-</sup>) are the major oxidation products, though production of other species such as dithionate (S(V), S<sub>2</sub>O<sub>6</sub><sup>2-</sup>) [39, 73] and disulphate (S(VI), S<sub>2</sub>O<sub>7</sub><sup>2-</sup>) have also been observed or reported [120, 121]. For instance, dithionate production was observable at 9% SO<sub>2</sub>, and it could account for as high as 15% of the oxidised sulphur at 15% SO<sub>2</sub> [39]. Its stoichiometric production from S(IV) oxidation can be expressed as:

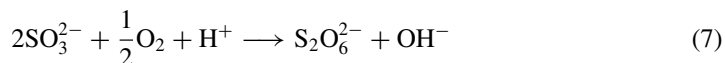

The selectivity between sulphate and dithionate depends primarily on the relative availability of O<sub>2</sub> and [S(IV)]/[Fe(III)] ratio. Dithionate production is usually preferred at high [S(IV)]/[Fe(III)] [122, 123], or low O<sub>2</sub> availability (section 5.2.3). The oxidation of S(IV) to sulphate is favoured in the presence of Cu(II), Cr(III), [122–125], though not Co(II), Mn(II), and Ni(II) [124]. According to [124], formation of dithionate is influenced by the initial pH, but is independent of the initial O<sub>2</sub> concentration. Their data showed that dithionate formation was maximum at pH 2.5.

S<sub>2</sub>O<sub>7</sub><sup>2-</sup> production was first documented via laser Raman spectroscopy by Chang *et al.* [120] in non-catalytic S(IV) oxidation under high oxygen partial pressure and acidic conditions. It was believed to be a redox intermediate with very short half-life (~50 s) that undergoes hydrolysis to give sulphate:

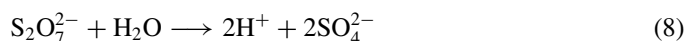

The production of S<sub>2</sub>O<sub>7</sub><sup>2-</sup> was also reported in a later investigation, also on non-catalytic S(IV) oxidation by O<sub>2</sub> [121]. Disulphate has been suggested to be an important intermediate in S(IV) oxidation with metal oxides as ‘catalysts’ [126, 127], though it is infrequently reported or measured.

Disregarding S<sub>2</sub>O<sub>6</sub><sup>2-</sup> and S<sub>2</sub>O<sub>7</sub><sup>2-</sup> as minor products, the oxidation of Fe(II) and S(VI) to higher states can be stoichiometrically expressed as in equation (9).

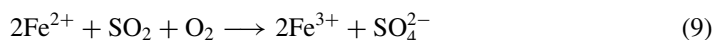

The overall catalytic oxidation of S(IV) can be expressed as in equation (10) when O<sub>2</sub> is relatively abundant and equation (11) when it becomes limiting [128].

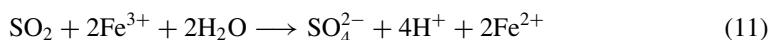
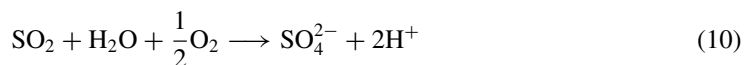

## 4.2 Reduction of species by Fe-S(IV)-O<sub>2</sub>

Reduction of Fe(III) to Fe(II) by S(IV) occurs when [Fe(III)] and [O<sub>2</sub>] are relatively low to [S(IV)]. S(IV) is transformed to sulphate or dithionate (S<sub>2</sub>O<sub>6</sub><sup>2-</sup>) [39, 73, 74, 122, 129–132], depending on how much S(IV) is in excess [39, 122, 129] and the relative supply of O<sub>2</sub> [73, 74]. Krause [74] reported insignificant Fe(III) reduction rates at [S(IV)]/[O<sub>2</sub>] ≤ 60, though the corresponding [Fe(III)]/[S(IV)] values were not reported.

## 5. Redox behaviour of pure Fe-S(IV)-O<sub>2</sub> system

### 5.1 Timeframe of transformation in aqueous Fe-S(IV)-O<sub>2</sub> system

**5.1.1 Timeframe for process kinetics.** The overall transformation process can be divided into three periods: induction period, steady state or pseudo-steady state period, and completion period. Semi-batch and batch studies showed that, upon the co-presence of Fe(II/III), S(IV), and O<sub>2</sub>, the system first goes through an induction period [4, 39, 74, 98, 133–135]. In industrial or engineered processes where S(IV)-O<sub>2</sub> and Fe(II) are continuously brought into contact and react, a true steady state will be established. In semi-batch (continuous supply of SO<sub>2(g)</sub>-O<sub>2(g)</sub>, fixed total [Fe]) mode, the induction period may be succeeded by a pseudo-steady state period [4, 39, 74] in which oxidation proceeds at fairly constant rates independent of the reductant level, most probably due to the limited supply of S(IV)-O<sub>2</sub> relative to reductant concentration. In the completion period, the oxidation rate declines as [Fe(II)] or [S(IV)] diminishes. The reaction timeframe in batch mode is more complicated. Steady O<sub>2</sub> consumption and H<sup>+</sup> production have been observed in batch mode [121]. However, the pseudo-steady state period may be absent if all reactants are equally limiting.

The length of the induction reflects the relative balance between the oxidative and the reductive species, and whether or not an optimal mixture of Fe-S(IV) and O<sub>2</sub> is present. For example, Tiwari *et al.* [4] found the duration of the induction period to be independent of initial [Fe<sup>3+</sup>] but shortened as O<sub>2</sub> partial pressure increased; Zhang *et al.* [39] observed a shortened induction period with higher SO<sub>2</sub> %.

**5.1.2 Timeframe for species kinetics.** Since Fe(III)-S(IV) interaction induces the rapid oxidation by O<sub>2</sub>, the relative timeframe for the formation and decay of various Fe(III)-S(IV) complexes will shed light on the catalytic nature of the system.

A skeletal timeframe for identified Fe(III)-S(IV) complexes is shown in scheme 3. These complexes are formed in sub-second timescale. Chemical equilibrium between Fe(III)-S(IV) complexes and their constituent ions are essentially established within the first 200 ms after mixing (phase I in scheme 3) [43, 45, 73, 136, 137]. Formation of mono-nuclear-mono-ligand complexes are completed first, followed by that involving three constituents (e.g., Fe<sup>III</sup>-bis(sulphito) complexes) or more [43, 45, 136]. This cascading pattern of simple complex formed first can be explained kinetically by the fact that all compounded complexes (e.g., Fe<sub>2</sub><sup>III</sup>(OH)<sub>2</sub><sup>4+</sup>) are built from the binding of simple complexes (e.g., Fe<sup>III</sup>OH<sup>2+</sup>) with another ligand or complex. Formation of Fe<sup>III</sup>SO<sub>3</sub><sup>+</sup>, Fe<sup>III</sup>(SO<sub>3</sub>)<sub>2</sub><sup>-</sup> (cis- and trans-), and Fe<sup>III</sup>(SO<sub>3</sub>)<sub>3</sub><sup>3-</sup> were reported at acidic, excess S(IV) conditions [43]. Analysis of absorbance spectra in early times showed that the bis(sulphito) complexes were formed within 5–10 ms, whereas the formation timeframe for tris(sulphito) complex was about 10–200 ms. The longer formation period for Fe(III)-tris(sulphito) complex can be understood by its dependence on excess S(IV). In a similar study at acidic but excess Fe(III) condition, FeSO<sub>3</sub><sup>+</sup> formation was

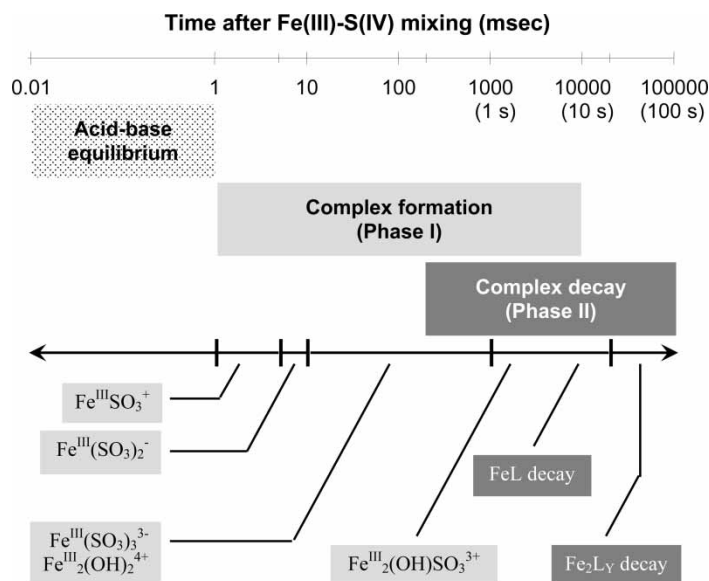

SCHEME 3 Timeframe for Fe(III)-S(IV) complexes formation and decay.

observed again within the first 200 ms [137]. Due to excess Fe(III), dimerized hydroxo complex ( $\text{Fe}_2^{\text{III}}(\text{OH})_2^{4+}$ ) formation was also observed [138]. The dimerization equilibrium between  $\text{Fe}_2^{\text{III}}(\text{OH})_2^{4+}$  and  $\text{FeOH}^{2+}$  was coupled to the formation of  $\text{Fe}_2^{\text{III}}(\text{OH})\text{SO}_3^{3+}$ , and the formation timeframe was identified to be from 1 to 10 s [45]. The more varied and later formation period for  $\text{Fe}_2^{\text{III}}(\text{OH})\text{SO}_3^{3+}$  can again be explained by the extended time needed to  $\text{Fe}^{\text{III}}\text{OH}^{2+}$  and  $\text{Fe}^{\text{III}}\text{SO}_3^+$  to meet and interact. Conklin *et al.* [136] observed roughly two kinetic phases. The first phase ( $\tau_{1/2} \sim 3$  ms) was believed to correspond to formation of  $\text{FeSO}_3^+$  from  $\text{FeOH}^{2+}$  and S(IV), while the second phase ( $\tau_{1/2} \sim 30$  ms at excess S(IV),  $\tau_{1/2} \sim 200$  ms at excess Fe(III)) may be related to isomerization from Fe-SO<sub>3</sub> to Fe-OSO<sub>2</sub> linkage [136, 139]. The two-phase distinction was consistent with the findings in an earlier study [140].

The complex formation phase, which ends roughly at around 200 ms to 1 s, is succeeded by a decay phase for Fe(III)-S(IV) complexes [43, 45]. Kraft *et al.* [73] commented that the complexes were unstable after phase I, and the decay phase corresponded to the intra-complex electron transfer reaction that took place between Fe(III) and S(IV). Based on kinetic analysis of absorbance, the decay of  $\text{Fe}^{\text{III}}\text{SO}_3^+$  took place from about 1 to 20 s [43, 73], and the decay after 20 s was attributed to the intra-complex electron transfer in the compounded complexes such as  $\text{Fe}^{\text{III}}(\text{SO}_3)_2^-$ . The decay of  $\text{FeSO}_3^+$  was observed to be about 10 times faster than that of the bis or tris(sulphito) complexes. Likewise, Lente *et al.* also attributed the decline in absorbance after  $\sim 10$  s to the Fe(III)-S(IV) induced oxidation by O<sub>2</sub> [45]. The timeframe for subsequent chemical transformations is less well characterized.

The period or phase durations presented in scheme 3 are not absolute. They vary with temperature and pH. For instance, the formation phase was shortened from 200 to 50 ms as temperature was raised from 10 °C to 25 °C [45], and from 200 ms to 20 ms when pH was lowered from 2 to 1 [136]. Finally, both Kraft *et al.* and Lente *et al.* consistently found that oxygen did not influence the formation rate of Fe(III)-S(IV) complexes [43, 45, 73]. As a final note, it should be emphasized that the early-time period (0  $\sim$  100 s) is not the same as the 'induction' period mentioned in 5.1.1. The latter refers to the delayed on-set of Fe(III)-S(IV) interaction as a result of highly reducing initial condition (e.g., high [Fe(II)] or [S(IV)]).

## 5.2 Factors influencing redox chemistry in Fe-S(IV)-O<sub>2</sub> system

**5.2.1 Fe.** It is generally agreed that Fe(III) is the active ‘catalyst’ that brings about the oxidative power of S(IV)-O<sub>2</sub> and that Fe(II) is catalytically inactive [26, 134, 141]. The critical role of Fe(III) in oxidation reactions involving SO<sub>2(g)</sub>-O<sub>2(g)</sub> was demonstrated [21]. Induced S(IV) oxidation was observed to proceed less efficiently [64] or even stop [98] when Fe(II) was the dominant iron species. The non-catalytic or even prohibitive nature of Fe(II) is further confirmed by its effect on the induction period (section 5.1.1). The induction period is extended in the presence of Fe(II) [4, 39, 74, 98, 133] but much shortened when started with Fe(III) [135]. It has been suggested that the redox unreactive or even prohibitive nature of Fe(II) may be caused by its stable interaction with SO<sub>4</sub><sup>2-</sup> (see 5.2.8) [64, 98, 142].

However, Fe(II) catalyzed S(IV) oxidations have been reported, though Fe(II) did not catalyze S(IV) oxidation as efficiently as Fe(III) [64, 116]. It is unclear whether the catalysis was carried out by Fe(II) or by trace levels of Fe(III) [60].

**5.2.2 Sulphites S(IV).** Semi-batch investigations on Fe(II) oxidation by SO<sub>2(g)</sub>-O<sub>2(g)</sub> showed that an optimal SO<sub>2</sub> % range exists for Fe(II) oxidation. Fe(II) oxidation rate decreases below this optimal range while Fe(III) reduction takes place at SO<sub>2</sub> % levels above it due to excess SO<sub>2</sub> input. The optimal SO<sub>2</sub> % range is strongly pH and temperature dependent. Ferron *et al.* [115] studied the reaction at 80 °C and pH 3.5 and found that the optimal SO<sub>2</sub> % to be between 2 to 5%. Zhang *et al.* [39] found the optimal SO<sub>2</sub> % to be about 14% and 2% at 40 °C and 80 °C, respectively.

**5.2.3 O<sub>2</sub>.** O<sub>2</sub> is the ultimate electron acceptor while Fe(III) and S(IV) together serves the ‘catalytic’ role of kinetically inducing and speeding up redox reactions (section 4). It also partly determines the critical switch of the system between its oxidative role (section 4.1) and its reductive one (section 4.2). The selectivity of S(IV) oxidation products is also influenced by O<sub>2</sub>. Podkrajšek *et al.* [143] observed minor dithionate (S<sub>2</sub>O<sub>6</sub><sup>2-</sup>) production only in Fe(III)-S(IV)-N<sub>2</sub> system while only sulphate was found in the presence of O<sub>2</sub>. The exclusive S<sub>2</sub>O<sub>6</sub><sup>2-</sup> formation under anoxic condition was similarly observed in non-catalytic S(IV) oxidation studies [38, 71, 144]. However, the data in [73] convincingly demonstrated that S<sub>2</sub>O<sub>6</sub><sup>2-</sup> production was enhanced in the presence of O<sub>2</sub> and higher [Fe(III)].

**5.2.4 [Fe(III)]/[S(IV)], [Fe(III)]/[Fe(II)], [S(IV)]/[O<sub>2</sub>] ratios.** These ratios determine the redox behaviour of Fe-S(IV)-O<sub>2</sub> system. When the system is characterized by high [Fe(III)]/[S(IV)], high [Fe(III)]/[Fe(II)], and low [S(IV)]/[O<sub>2</sub>], the system behaves overall as an oxidant. On the contrary, when these ratios point in the opposite direction, the system redox tendency will be predominantly reducing. In the later case, oxidation of reduced species will proceed very slowly, until sufficient number of catalytically active metal centers (e.g. Fe(III)) has been generated.

In theory, all three ratios are important in determining the redox inclination of the system. In practice, however, often only one of them is controlling. The reason for this is analogous to the case of a multiple-reactants reaction where usually only one of them is limiting, or that among a series of sequential reaction steps, only one step is rate limiting for the entire scheme.

For instance, Brandt *et al.* [114] observed that when all dissolved oxygen was consumed the redox recycling of Fe would come to a halt, implying that the [S(IV)]/[O<sub>2</sub>] was controlling. In another case where Fe(II) oxidation by SO<sub>2</sub>-O<sub>2</sub> was studied, Tiwari *et al.* [4] found the duration of the induction period to be independent of initial [Fe<sup>3+</sup>] but shortened as O<sub>2</sub> partial pressure

increased. Qualitatively, this means that  $[\text{Fe(III)}]/[\text{Fe(II)}]$  was quite low (highly reductive) when compared to  $[\text{S(IV)}]/[\text{O}_2]$ , and that the reductive tendency of the system could be reversed by supplying more O<sub>2</sub>.

On the contrary, Zhang *et al.* [39] reported a shortened induction period with higher SO<sub>2</sub> % up to a point, implying the system catalytic activity had not reached its maximum and that it could be further boosted with more S(IV) 'catalyst'. Such observation raises an important point about S(IV). Being a reducing species, excess S(IV) can prevent the system acting as an oxidant; however, as part of the 'catalyst', S(IV) is also needed for rapid oxidation. Hence a critical balance exists between the reducing nature of S(IV) and its catalytic character, whereas for Fe(III) and O<sub>2</sub>, the more they are present, the better is the system, kinetically, as an oxidant.

In a recent review, Yermakov and Purmal [66] have attempted to characterize the boundaries for  $[\text{Fe(III)}]/[\text{Fe(II)}]$ ,  $[\text{Fe(III)}]/[\text{S(IV)}]$ , and how these two ratios were related in the light of a radical-based mechanism (see section 6.2). However, the  $[\text{S(IV)}]/[\text{O}_2]$  ratio itself, as well as its relation to the other two ratios, were left out of the analysis.  $[\text{S(IV)}]/[\text{O}_2]$  may be of no consequence to atmospheric systems because O<sub>2</sub> is much more abundant than S(IV) in rain-, cloud-, or fog-waters. But in industrial processes or engineered systems,  $[\text{S(IV)}]/[\text{O}_2]$  is very likely to be important, as various studies on the Fe-SO<sub>2(g)</sub>-O<sub>2(g)</sub> system have shown [4, 74, 75, 115].

**5.2.5 pH.** Acidity influences the Fe-S(IV)-O<sub>2</sub> redox chemistry primarily by affecting the speciation of Fe ions and S(IV), which in turn controls the concentration of catalytically active Fe-S(IV) complexes such as  $\text{FeSO}_3^+$  [45, 73],  $\text{Fe(OH)(SO}_3\text{H)}^+$  [60]. These complexes are thought to be the rate limiting species in the induced oxidation of Fe(II), S(IV), or other compounds. pH also controls the total amount of dissolved Fe ions by constraining the catalytically active Fe(III). Fe(III) precipitates readily with increasing pH, and the precipitated or polymerized Fe(III) are less redox-reactive compared with dissolved Fe(III) (section 3.2.2). This may partially explain why the S(IV)-oxidation rate generally declines with increasing pH.

Electron transfer reactions also depend strongly upon pH. Generally, anions in deprotonated form undergo oxidation more readily because of the relatively richer electron densities. This effect has been well-documented for the oxidation of organic compounds [80]. Similarly, deprotonated sulphites lose electrons more willingly than the protonated forms. Such trends can be observed for the rate constants reported for various elementary reactions (see C1 and C2 in Appendix C).

It is rather difficult to summarize the overall influence of pH on Fe(III)-S(IV) induced oxidation because a change in pH often favours one aspect (e.g., S(IV) in more reactive form) of the reaction kinetics and disfavors another (e.g., less Fe(III)). Literature has been reported with a widely varied reaction order in  $[\text{H}^+]$  dependence at different pH ranges and  $[\text{Fe}]$ ,  $[\text{S(IV)}]$ , and  $[\text{O}_2]$  settings [26].

Yermakov and Purmal [60, 66] attempted to explain the influence of pH on catalytic S(IV) auto-oxidation in a systematic way. They plotted S(IV) normalized oxidation rate data from five studies [50, 133, 145–147] against pH, and tried to show that the general bell-shape rate data corresponded to the normalized distribution of  $\text{Fe(OH)SO}_3\text{H}^+$ , which they believed to be the rate determining complex (section 6.2.1). Although the  $\text{Fe(OH)SO}_3\text{H}^+$  curve was systematically biased toward the lower pH regime and fitted well only the data from two of the studies, the plot did illustrate two important points. The first is that S(IV) oxidation is determined primarily by the speciation of some rate determining Fe(III)-S(IV) complexes, which in turn depends heavily on the system pH. The second is to affirm the general bell shape of rate vs pH, with an optimal oxidation range from about pH 3 to 5. This is consistent with the division of rate into a 'high' pH (pH > 5) and a 'low' pH (pH < 3) regime, as proposed by Martin *et al.* [67]. As the system pH moves away from the optimal pH 3–5 range, the oxidation

rate of Fe(II) (or other low valency metal ions) or S(IV) is expected to decline, as shown by the results in other Fe(II) oxidation [39, 115, 148–150] and S(IV) auto-oxidation studies [94, 151]. The importance of speciation on oxidation rate is reinforced by an observation of Huss *et al.* [150] who showed addition of HCl (0.005–0.2 M) could extend the induction period (section 5.1.1) considerably (0.5–40 hrs) in catalytic Fe(II) oxidation.

pH also influenced oxidation product selectivities. For instance, dithionate ( $S_2O_6^{2-}$ ) formation is generally favoured at high acidity [152] and at low  $O_2$  levels [38, 71, 124] due to the suppression of sulphate production [152].

**5.2.6 Temperature.** The rate of Fe(II) oxidation catalyzed by S(IV) generally increases with temperature until an optimum point and declines with further temperature increase. Schlitt *et al.* [128] observed S(IV) oxidation rate increased with higher temperature up to a limit beyond which no further increase was found. Tiwari *et al.* [4] studied the Fe- $SO_{2(g)}-O_{2(g)}$  system from 50 °C to 90 °C and found the maximum Fe(II) oxidation rate at 70 °C. A similar temperature range (65 °C to 80 °C) on the identical system was explored in another study [115], and the reaction rate was found to increase slightly with temperature. Zhang *et al.* [153] studied Fe(II) oxidation by  $SO_2-O_2$  from 40 °C to 95 °C and found the rate to be the fastest at around 80 °C. The presence of an optimal temperature on Fe(II) oxidation rate has been interpreted as a balance point between the kinetic benefit of higher temperature and the disbenefit of reduced  $O_2$  solubility (see A1 in Appendix A).

**5.2.7 Ionic effect—ionic strength.** Generally, oxidation rate tends to decline with higher ionic strength [150, 154–160]. The rate-retarding effect imposed by ions may be understood at two levels. The primary ionic effect is non-ionic specific. Stronger ionic interaction in the aqueous phase alter the activities of reactive species, ultimately affecting the reaction rate. The primary ionic effect can be appropriately accounted for with ionic-strength corrected activity coefficients.

The secondary ionic effect is the species-specific influence due to physicochemical nature of the particular ions. In Fe-S(IV)- $O_2$  system, anions can bind to the catalytically active Fe(III) and form complexes. Anions such as  $Cl^-$  or  $NO_3^-$  are very labile and co-ordinate to Fe(III) rather weakly. However, chelators such as oxalate ( $C_2O_4^{2-}$ ) bind strongly to Fe(III) and so may lessen or even inhibit its redox-catalytic capacity. Anions such as carboxylates may also act as radical scavengers, which have been demonstrated to interfere with the Fe(III)-S(IV) induced redox chemistry in various way [49, 161–163] (section 5.4.2). Anions like oxalate can act as strong-binding ligand and as radical scavenger while  $Cl^-$  and  $NO_3^-$  are relative poor in both.

Non-Fe cations may also exert secondary effects depending on their chemical nature and relative abundance. Non-transition metal ions such as  $Ca^{2+}$  and  $Mg^{2+}$  have been found to lower S(IV) oxidation [164]. Although they are poor co-ordination centers (i.e. small  $\log \beta$ ) [79, 81], at high concentrations they may control Fe and S(IV) speciations, thereby altering the concentrations of rate determining complexes in Fe-S(IV)- $O_2$  system. Non-Fe transition metal ions with reduced valencies have also been reported to inhibit Fe(II) or S(IV) oxidation to some extent (see section 5.4.4).

**5.2.8 Ionic effect—ion-specific effects.** Millero [159] investigated the effects of specific ions on Fe(II) oxidation by  $O_2$ . At constant pH and ionic strength, the rate was found to vary with anion type, with the oxidation of Fe(II) to be fastest in the presence of  $HCO_3^-$ , followed in descending order by  $Br^-$ ,  $ClO_4^-$ ,  $NO_3^-$ ,  $Cl^-$ , and  $SO_4^{2-}$ . The observed ion-specific effect on rate was explained by the varying strength of interactions between the anions and Fe(II).

The rate-retarding effect of sulphate on catalytic S(IV) oxidation has been attributed to it complexing with Fe(II). Martin [64] suggested that Fe(II) and S(IV) form a complex that was sufficiently stable to resist oxidation by either O<sub>2</sub> or H<sub>2</sub>O<sub>2</sub>. Considering the comparable rate of H<sub>2</sub>O<sub>2</sub> and HSO<sub>5</sub><sup>-</sup> induced S(IV) oxidation [165], it may be inferred that the complex would also resist oxidation by HSO<sub>5</sub><sup>-</sup>. Huss *et al.* [98, 150] also observed similar inhibitive effect of sulphate on SO<sub>2</sub> oxidation in the presence of Fe(II) and likewise explained the phenomenon with the stability of FeSO<sub>4</sub> complex. By similar argument, Cho [142] had stressed the importance of uncomplexed free metal ion concentrations in kinetic calculations and suggested that the formation of all Fe(II)- and Fe(III)-S(VI) complexes be accounted for. Iwai *et al.* [149] studied Fe(II) oxidation by O<sub>2</sub> in sulphuric acid and observed that H<sub>2</sub>SO<sub>4</sub> had no effect on the rate constant beyond 1 M. This may suggest oxidation of Fe(II) takes place even as Fe<sup>II</sup>SO<sub>4</sub>.

Catalysis of S(IV) oxidation due to Cl<sup>-</sup> has been reported in acidic to near neutral pH range [156, 157, 166]. This may be due to the formation of Cl<sub>2</sub><sup>\*-</sup>, which then induces S(IV) oxidation via a radical pathway. Similar halogen molecule radicals have been found to react readily with S(IV) (see C1 in Appendix C) in atmospheric systems.

The specific effects of other ions and compounds are covered in section 5.4.

**5.2.9 Aging effect.** The rate of S(IV) auto-oxidation under Fe(III) catalysis generally decreases with aging (i.e. hydration time of Fe(III)). The concentration of FeOH<sup>2+</sup>, which is one of the catalytically active forms of Fe(III), may change depending on the age of the solution [167]. Novič *et al.* [168] studied S(IV) oxidation rate by adding S(IV) to Fe(III) solution after different hydration times and found the rate slowed down when S(IV) was added later. Reduced catalytic activity due to aging of Fe(III) solution was also observed by Brandt *et al.* [94]. Although they attributed the lowered oxidation rate to the formation of dimeric and polymeric Fe(III)-hydroxo species (i.e., Fe<sub>m</sub><sup>III</sup>(OH)<sub>n</sub><sup>(3m-n)+</sup>, m, n ≥ 2), their rate data showed that the S(IV) oxidation rate constant was essentially constant over the first 2 hrs. Considering the formation of dinuclear Fe(III)-hydroxo species happens within sub-second timescales (section 5.1.2), the claim was not well supported. The results from both studies were consistent with the polymerization theory in a previous review [100].

### 5.3 Catalytic synergism in Fe-S(IV)-O<sub>2</sub> system

It has been observed that when more than one transition metal ion is present in the aqueous solution, the rate of S(IV) autoxidation could be promoted to a level greater than the sum of the rate of reactions catalyzed by individual metal ions. The most studied and recognized synergistic system for S(IV) autoxidation was that catalyzed by Fe and Mn, in particular Fe(III)-Mn(II) [51, 64, 112, 147, 169–171] and Fe(III)-Cu(II) [119, 131, 170]. However, no synergism was reported for Fe(III)-Mn(II) by [131] nor Fe(III)-Cu(II) by [64]. The synergism of other Fe-Me pairs are more disputable. Brandt [171] observed catalytic synergism in Fe(III) induced S(IV) auto-oxidation when Co(II), Ni(II), Cr(III) were present, though others have observed no synergism in their presence [64, 131]. Others reported Fe-Me synergistic pairs are Fe(II)-Mn(II), Fe(III)-Mn(II)-Pb(II) [51, 172] and Fe(II)-Cu(II) [4, 75]. Non-Fe catalytic synergistic combinations can be found in [26, 173].

Catalytic synergism may be conceptually understood as the participating metal ions mutually reinforcing the redox-catalysis that results in an enhanced overall reaction rate exceeding that expected from individual catalysis. Grgić *et al.* [51] proposed that Fe(III)-Mn(II) catalytic synergism could be understood through the coupling of the individual redox cycling



mechanisms into one. Mn(II) is first oxidised by Fe(III) to Mn(III). Since Mn(III) could oxidise S(IV) much faster than Fe(III) [76],  $\text{SO}_3^{\bullet-}$  (or  $\text{HSO}_3^{\bullet}$ ) radicals are rapidly formed when S(IV) reacted with Mn(III). The resulting radicals then regenerate Fe(III) from Fe(II), quickly branching up the propagation rate of oxidative intermediates such as  $\text{SO}_5^{\bullet-}$ ,  $\text{SO}_4^{\bullet-}$ , and  $\text{HSO}_5^-$ . The cross-cycling of redox catalysts is completed when the regenerated Fe(III) oxidised more Mn(II) to Mn(III).

But catalytic synergism is not always exhibited in a synergistic pair. This is due to the fact that a synergistic catalysts pair generally consists of a metal catalyst in a relatively oxidised state (e.g., Fe(III)), while the other catalyst is in its reduced state (e.g., Mn(II)). Thus if the reductive catalyst is controlling, the onset of catalytic synergism will be delayed or even halted. For instance, Tiwari *et al.* [4] found that a small amount of  $\text{Cu}^{2+}$  (1 g/L) could increase the rate of Fe(II) oxidation in the presence of  $\text{SO}_2\text{-O}_2$ . However, at  $[\text{Cu}^{2+}] \geq 10$  g/L, the oxidation rate of Fe(II) began to decline. Zhang *et al.* [75] investigated the effect of  $\text{Cu}^{2+}$  on both the oxidation of Fe(II) by  $\text{O}_2$  alone and that by  $\text{SO}_2\text{-O}_2$  gas mixture. They found that while the presence of  $\text{Cu}^{2+}$  increased the rate in pure  $\text{O}_2$ , it produced an inhibiting effect on Fe(II) oxidation in the  $\text{SO}_2\text{-O}_2$  case. It was suggested that  $\text{CuO}_2^+$  and  $\text{H}_2\text{O}_2$  were formed and they promoted Fe(II) oxidation by pure  $\text{O}_2$ . In the case of  $\text{SO}_2\text{-O}_2$ ,  $\text{Cu}^{2+}$  acted as an inhibitor of the free radical chain. The supporting evidence for the conclusions was that hydroquinone, a free radical scavenger, inhibited the oxidation of Fe(II) by  $\text{SO}_2\text{-O}_2$ , while the rate of the pure  $\text{O}_2$  case was unaffected.

The extent or even presence of a synergistic effect depends upon factors such as the ratio of catalyst concentrations, pH, the initial valence state of metal ions, and whether organic molecules that may act as complexing agent or inhibitor are present [26, 64, 147, 172].

#### 5.4 Catalytic inhibition in Fe-S(IV)- $\text{O}_2$ system

As early as the 1910's, compounds such as alcohols and aldehydes have been shown to inhibit transition metal catalyzed S(IV) oxidation by  $\text{O}_2$  [1]. Numerous studies have shown that catalytic S(IV) auto-oxidation can be slowed down or even stopped when certain organic molecules, known as inhibitors, are present [6, 38, 39, 48, 49, 116, 161–163, 174–179]. These inhibitors reduce the speed and extent of the metal catalyzed S(IV) oxidation in primarily four ways [67, 180, 181]: 1) by deactivating the metal catalyst(s) through strong complexation, 2) by acting as radical scavenging agents, 3) by forming stable adducts with S(IV) oxides, and 4) by acting as competing reductants.

**5.4.1 Inhibition due to chelators.** Chelating agents such as oxalate [134, 180–183], acetate/formate [67, 181, 184], EDTA [77, 121, 185, 186–188], phenanthroline [116, 189, 190] can bind strongly to metal catalysts and reduce their catalytic activities. Complexed metal centers may interact less readily with S(IV) and other species due to constrained electronic structure and/or steric hindrance from the binding ligands. The redox potential of the metal center may be altered by associated ligands [191, 192], and hence change its tendency to participate in an electron transfer reaction (equation (12)).

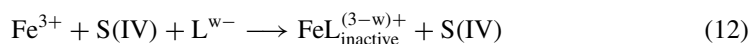

Chelating agents also influence the redox speed by inactivating the reduced Fe(II). Grgić *et al.* [180] observed the onset, duration, and stability of Fe(II) levels to be prolonged and stabilized in the presence of oxalate, suggesting Fe(II) may also be shielded from oxidants in

the presence of strong chelators (equation (13)).

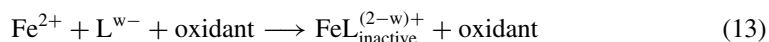

**5.4.2 Inhibition due to radical scavengers.** Radical scavengers are compounds with electron-rich structures such as C  $\pi$ -bonds, aromatic rings, conjugated dienes, or hydroxyl groups which allow them to react readily with radicals. Radicals react with the electron rich structures most frequently by addition (bonding to the structure) or H-abstraction (convert the scavenger into a radical by H-removal) [80]. Their interrupting effect on the free radical chain can be observed at relatively dilute levels ( $10^{-6}$  to  $10^{-4}$  M) [49, 161, 178]. Some commonly reported radical scavengers are alcohols [49, 55, 193–195], phenols [58, 112, 161, 196], hydroquinones [161, 197, 198], aromatic amines [198], benzenes [198–200], alkenes [178, 179, 201], carboxylates [58, 202], saccharides, indoles, and amides [161].

The actions of a generic radical scavenger (HIN) on oxysulphur radicals ( $\text{SO}_X^{\bullet-}$ , X = 3–5), which have been proposed as key reactive oxidants in  $\text{Me}^{n+}$ -S(IV)-O<sub>2</sub> system (see section 6.1.1), are shown in equations (14)–(17). If HIN has good resonance structure, its radical form will be relatively stable, and so it can only react with another radical [162].

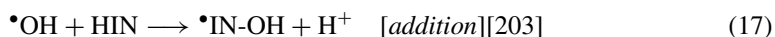
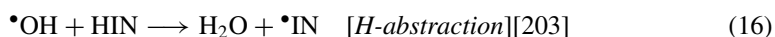
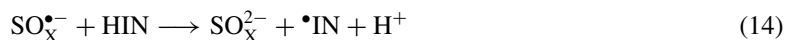

**5.4.3 Inhibition due to C-S(IV) adducts formation.** Inhibitors may also interrupt S(IV) oxidation by forming stable adducts with S(IV) ions. Aldehydes, for example, have been shown to inhibit S(IV) oxidation in this manner [177, 204]. Well known examples of this group are aldehydes, which are found in atmospheric waters [174, 204, 205], and  $\alpha$ -keto acids [161, 174, 175, 177, 206]. Adducts are formed through nucleophilic attack on the carbonyl carbon, with S in S(IV) as nucleophile. The formation reactions are shown in equations (18) and (19) [207].

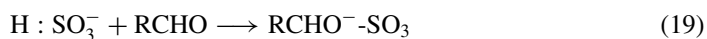
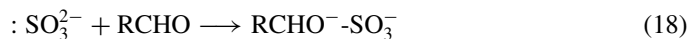

**5.4.4 Inhibition due to competing reductants.** Competing reductants include not only reduced organic molecules but also low valence transition metal ions. Ions such as Cr(III), Cu(II), and V(V) have been reported to exhibit inhibitory effects on catalytic S(IV) oxidation as well [4, 75, 151]. The inhibitive action of low valence metal ions are shown in equation (20).

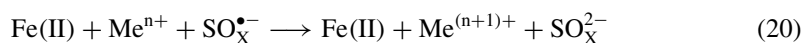

Reduced transition metal ions will compete with Fe(II) or S(IV) in getting oxidised, but the long term effect may be catalytic rather than inhibitory. If the overall system is on the oxidative side, the inhibitory effect of reduced metal ions would simply be an induction period, after which S(IV) or Fe(II) oxidation proceeds even much faster due to Fe-Me catalytic synergism (see section 5.3).

**5.4.5 Unusual catalytic oxidation induced by inhibitors.** Recently, a number of organic inhibitors were found to exhibit catalytic, rather than inhibitive, effect on S(IV) oxidation at certain conditions. Terpenic derivatives such as cis-verbenol, and nopol [49]; phenol and gallic acid [176] were found to promote S(IV) oxidation when they are present at levels comparable to [Fe(III)]. Phenol, on the other hand, first promoted S(IV) oxidation, but then caused the rate to decay sharply at a later time.

Two radical mechanisms were proposed by Pasiuk-Bronikowska *et al.* [162, 176] to explain the switching of these inhibitors from negative to positive catalysis. The proposed model invokes the presence of monomeric and complex organo-radicals,  $A^\bullet$  and  $(HAA)^\bullet$ , to qualitatively explain the kinetic behaviour of catalytic S(IV) in the presence of gallic acid equations (21)–(25) and phenol (equation (26) followed by equations (21)–(25)).

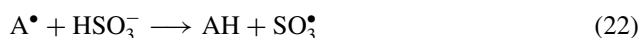
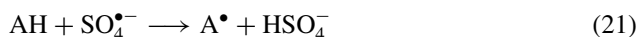

The second mechanism starts with a phenol-metal interaction equation (26), with the remaining reactions identical with equations (21)–(25):

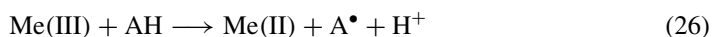

The dimeric or complex organo-radicals  $(AAH)^\bullet$  or  $(AA)^\bullet$  are weakly reactive and participate in only recombination reactions with other radicals, while the mono-radical  $(A^\bullet)$  is still reactive enough to attack non-radical species (e.g., (22), (23)).

Although the general organo-radical based mechanisms qualitatively explain the catalytic function observed for certain compounds, specific kinetic behaviour still needs more elaboration. For instance, when gallic acid was added to Fe(III)dCo(II)-S(IV)-O<sub>2</sub> system, the compound first inhibited catalytic S(IV) oxidation [176]. S(IV) oxidation proceeded at a stable rate for  $> \sim 1$  hr. After a long time ( $\sim 2$  hr), S(IV) oxidation rate began to change, oscillating between periods of enhanced and steady conversion rates. The mechanism consisting of equations (21)–(25) cannot sufficiently explain such kinetic behaviour.

## 5.5 Kinetics in Fe-S(IV)-O<sub>2</sub> system

A compilation of kinetic expressions from some studies relevant to Fe-S(IV)-O<sub>2</sub> system has been provided in C9 in Appendix C. The list is by no means comprehensive. It is given here to illustrate the greatly varied order of dependence on the concentrations of key redox species and H<sup>+</sup>, and the disagreement within experiments conducted at similar/same conditions.

Space limitation does not permit an in-depth discussion on theoretical kinetic expressions for different mechanisms. In 2003, Yermakov and Purnal published an ambitious review [66] with the hope to resolve a number of key mechanistic riddles that have been raised in the past Fe-S(IV)-O<sub>2</sub> studies. There, they offered a systematic and vigorous kinetic analysis on the catalytic redox behaviour from the perspective of oxysulphur radicals chain mechanism. A more accessible formulation of a generalized rate expression involving Fe, S(IV), and O<sub>2</sub> can be found in reviews by Hoffmann *et al.* [112, 208].

## 5.6 E<sub>H</sub> of Fe-S(IV)-O<sub>2</sub> system

The E<sub>H</sub> of Fe-S(IV)-O<sub>2</sub> and related metal catalysis systems has not been extensively studied, although its peculiarity has been documented. S(IV) is itself a reducing species, but when it is present in aqueous environment together with Fe(III) and O<sub>2(aq)</sub>, the overall system E<sub>H</sub> can be promoted to levels as high as or even exceeding the oxidation-reduction potential of the O<sub>2</sub>-H<sub>2</sub>O couple.

**5.6.1 Species contributing to high E<sub>H</sub>.** Devuyst *et al.* [132] studied the S(IV) oxidation by air in deionized water possibly contaminated with trace levels of metal impurities. They found the solution Eh increased beyond that of the O<sub>2</sub>-H<sub>2</sub>O couple at around pH 9 and observed the production of an unknown oxidant to increase with the E<sub>H</sub>. The observed oxidant could be stable for several hours and was reported to decompose rapidly to some gas, suspected to be O<sub>2</sub> or H<sub>2</sub>O<sub>2</sub>, upon the addition of Ca(OH)<sub>2</sub>. Because K<sub>2</sub>SO<sub>5</sub> was found to undergo similar decomposition under alkaline condition upon addition of Ca(OH)<sub>2</sub>, it was suggested that the oxidant was some kind of 'activated complexes' of the form MeSO<sub>5</sub><sup>(n-2)-</sup>, with SO<sub>5</sub><sup>2-</sup> accounting for the high oxidation potential observed at elevated pH.

In another Fe(III)-SO<sub>2(g)</sub>-O<sub>2(g)</sub> study, Zhang *et al.* [153] likewise reported unusually high E<sub>H</sub>, but at low pH (1–3). In the absence of SO<sub>2</sub>, the system E<sub>H</sub>, however, was always below the O<sub>2</sub>-H<sub>2</sub>O boundary. The observed E<sub>H</sub> with SO<sub>2</sub>-O<sub>2</sub> input was claimed to be similar to the oxidation potential of HSO<sub>3</sub><sup>-</sup>/HSO<sub>4</sub><sup>-</sup> and that of H<sub>2</sub>SO<sub>5</sub> hydrolysis. HSO<sub>3</sub><sup>-</sup> was claimed to be the reactive form based on the observation that high E<sub>H</sub> did not occur at pH < 0.5 < pK<sub>a</sub>(H<sub>2</sub>O.SO<sub>2</sub>), where the oxidation rate was slow. The maximum E<sub>H</sub> increased linearly with [Fe(III)] up to 0.03 M and then became independent beyond that concentration.

**5.6.2 Response of E<sub>H</sub> to system parameters.** Recently, Kuo [209] investigated the behaviour of E<sub>H</sub> in an aqueous Fe-S(IV)-O<sub>2</sub> system in response to [Fe(III)], [S(IV)], O<sub>2</sub>, mixing rate, pH, and glucose (as a reductant). The E<sub>H</sub> levels over 1.3 V were attained only when Fe(III), S(IV) and O<sub>2(aq)</sub> were all present and when sufficient mixing was applied. Furthermore, the E<sub>H</sub> of the system could be manipulated reversibly between the plus-1.3 V (hyper-E<sub>H</sub>) and the sub-0.9 V (hypo-E<sub>H</sub>) levels by addition of S(IV) at different amounts and frequencies. The effect of mixing and observation at different [S(IV)]/[Fe(III)] ratios led to the hypothesis that the local [S(IV)]/[Fe(III)] was critical to the response of the system E<sub>H</sub>. Stepwise S(IV) addition experiment showed that the plus-1.3 V levels could be achieved at [S(IV)]<sub>o</sub>/[Fe(III)] < 1. The system pH affected the response rate of E<sub>H</sub> to S(IV) injection, but not the maximum attainable value.

The presence of glucose, even at a trace level (3.5 × 10<sup>-7</sup> M), seem prevented the system from reaching the plus-1.3 V levels. The maximum E<sub>H</sub> attained by the system decreased as the concentration of glucose increased. Evolution of gas was not observed, implying glucose did not mineralize to CO<sub>2</sub>.

**5.6.3 The meaning of measured E<sub>H</sub> in Fe-S(IV)-O<sub>2</sub> system.** The meaning of the reported hyper-E<sub>H</sub> remains unclear. Zhang *et al.* [75] claimed the high E<sub>H</sub> they observed after 30 minutes was the equilibrium system E<sub>H</sub>, without showing any E<sub>H</sub>-time plots. This is inconsistent with the observation by Kuo [209], where Eh was found to change with time, and more importantly, with the addition of S(IV). Moreover, given O<sub>2</sub> as the ultimate oxidant, the equilibrium E<sub>H</sub> should not exceed that of the O<sub>2</sub>-H<sub>2</sub>O.

Zhang *et al.* [75] also attributed the high E<sub>H</sub> to SO<sub>5</sub><sup>2-</sup> with reference to a similar observation made by Devuyst *et al.* [132]. However, their system was at low pH (0–3) while that investigated

by Devuyst *et al.* was in the alkaline range (pH > 9). Ca(OH)<sub>2</sub> addition to one sample with plus-1.3 V E<sub>H</sub> revealed no gas formation, suggesting either the complete absence of SO<sub>5</sub><sup>2-</sup> in the solution, or that its concentration was undetectable [209]. The potential of SO<sub>5</sub><sup>•-</sup> is expected to be around 1.4 V at pH 2, and 0.9 V at pH > 10 [58]. The high E<sub>H</sub> (~1.4 V) has been shown to be highly stable for more than 10 hrs [132, 209]. How could the relatively stable E<sub>H</sub> be reconciled with highly reactive species such as SO<sub>5</sub><sup>•-</sup> or SO<sub>5</sub><sup>2-</sup>? Or could the system be at E<sub>H</sub> disequilibrium [31]?

## 6. Mechanisms of redox reactions in aqueous Fe-S(IV)-O<sub>2</sub> system

Any feasible, valid mechanism for the Fe catalysis of S(IV) (or other reductants) oxidation must at least be able to explain: 1) the ‘catalytic’ or induced redox chemistry involving Fe-S(IV) interactions in the presence of O<sub>2</sub>, 2) the co-oxidation of Fe(II) and S(IV) to Fe(III) and S(VI), under sufficient O<sub>2</sub> supply and appropriate [Fe(III)]/[S(IV)] ratio, 3) the catalytic synergism on S(IV) or Fe(II) oxidation in the presence of other transition metal ions, and 4) the overall redox behaviour in the presence of inhibitors.

### 6.1 Mechanisms for redox reactions in pure aqueous Fe-S(IV)-O<sub>2</sub>

The mechanisms proposed for the reactions in Fe-S(IV)-O<sub>2(aq)</sub> system can be divided into three categories: (a) free radicals based mechanism, (b) inner-sphere electron transfer mechanism within Fe-sulphito complexes, and (c) mixed mechanisms of (a) and (b) [26, 77]. All three categories recognize the formation of some Fe-S(IV) complexes as the first step of the reaction network. The radicals based and the electron transfer mechanisms differ primarily in the account of the subsequent reactions undertaken by the Fe-S(IV) complexes.

### 6.2 Free radical chain mechanism—oxysulphur radicals

The oxysulphur radicals chain model has been most frequently quoted to explain redox chemistry in Fe-S(IV)-O<sub>2</sub> system. First proposed by Backström [210] and later modified by Haber [211] to the current framework, the model essentially suggests Fe(III)-S(IV) complex(es) decomposes to produce SO<sub>3</sub><sup>•-</sup>, which eventually leads to the formation of other oxidative oxysulphur intermediates (SO<sub>4</sub><sup>•-</sup>, SO<sub>5</sub><sup>•-</sup>, HSO<sub>5</sub><sup>-</sup>, and SO<sub>5</sub><sup>2-</sup>) in the presence of O<sub>2</sub>. These highly oxidative oxysulphur species are responsible for the rapid oxidation of reductants, such as S(IV) or organic species, as well as the regeneration of Fe(III). The oxysulphur radical chain mechanism has been widely supported and favoured for it can best explain the rapid auto-oxidation of S(IV) [75, 76, 114, 212, 213] and the inhibitory effects of organic molecules with radical scavenging capability [48, 161, 163, 214].

**6.2.1 Oxysulphur radicals mechanism—radical initiation phase.** The mechanism can be divided into three phases: initiation, propagation, and termination. The initiation phase begins with the formation of Fe(III)-S(IV) complex(es) (equation (27)), which undergoes an intra-complex single electron transfer to produce SO<sub>3</sub><sup>•-</sup> (equation (28)).

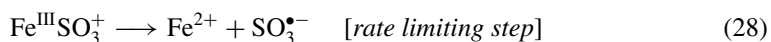
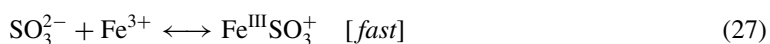

The rate limiting step for the entire reaction network depends on the how fast Fe-S(IV) complex(es) decays, via thermolysis, to yield SO<sub>3</sub><sup>•-</sup>. Various Fe-S(IV) complexes have been claimed to be the key SO<sub>3</sub><sup>•-</sup> yielding complex. Kraft *et al.* [73] and Lente *et al.* [45] claimed that Fe<sup>III</sup>SO<sub>3</sub><sup>+</sup> (i.e. equation (28)) was the rate determining Fe(III) complex based on early micro-second scale observations. Brandt *et al.* [114], suggested in a scheme that mono-Fe(III) center complexes of the generic form Fe<sup>III</sup>(HSO<sub>3</sub><sup>-</sup>)<sub>n</sub><sup>(3-n)+</sup> may be controlling the overall rate. Ziajka *et al.* [214] and Reddy *et al.* [133] believed the rate limiting complex was Fe(OH)(SO<sub>3</sub>H)<sup>+</sup>, formed from the co-ordination of FeOH<sup>2+</sup> + HSO<sub>3</sub><sup>-</sup>. Yermakov *et al.* [215] also favoured Fe(OH)(SO<sub>3</sub>H)<sup>+</sup> over the other Fe-S(IV) complexes as rate determining in their modeling analysis, though no specific reasons were provided for the choice.

An alternative initiation path (equations (29)–(31)) was proposed by Martin *et al.* [67] with Fe<sub>2</sub><sup>III</sup>(OH)<sub>4</sub><sup>2+</sup> as the rate determining complex that decays to release •OH:

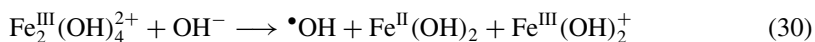

Brandt *et al.* [94] studied the effect of solution aging on Fe(III) catalyzed S(IV) oxidation and found that the catalytic activity of Fe(III) decayed with aging. The reduced catalytic was attributed to the formation of dimeric and polymer Fe(III)-hydroxo species. However, their rate data showed that S(IV) oxidation rate constant was essentially constant over the first 2 hrs. Since Fe<sub>2</sub><sup>III</sup>(OH)<sub>4</sub><sup>2+</sup> is formed in sub-second scale (see section 5.1.2), one may not conclusively claim that the dimeric Fe(III)-hydroxo complex is catalytically insignificant. However, Lente *et al.* [45] rejected another dimeric candidate, Fe<sub>2</sub>(OH)SO<sub>3</sub><sup>3+</sup>, as an important contributor in the initiation phase based on a model fitting argument.

**6.2.2 Oxysulphur radicals mechanism—radical propagation phase.** The propagation phase begins with rapid reaction between SO<sub>3</sub><sup>•-</sup> and O<sub>2</sub> to form SO<sub>5</sub><sup>•-</sup> (equation (32)), which in turn leads to the formation of other reactive oxysulphur intermediates (equations (33)–(35)).

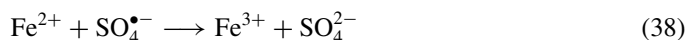
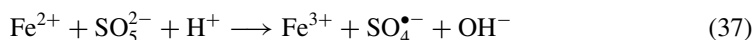
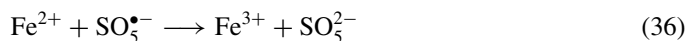
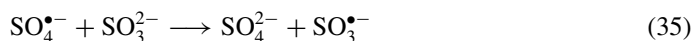
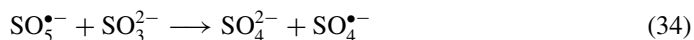
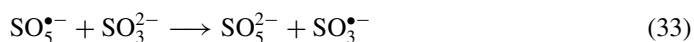

Fe(III) is regenerated by the reactive oxysulphur intermediates via equations (36)–(38). Chain branching occurs in equation (36) and equation (37) because the restoration of Fe(III) is accompanied by the additional formation of oxysulphur oxidants (SO<sub>5</sub><sup>•-</sup>, SO<sub>5</sub><sup>2-</sup>). An important refinement on the radical mechanism was the inclusion of Caro's acid (HSO<sub>5</sub><sup>-</sup>) into the main mechanism [55, 118, 379] because it adds a new branching pathway [66]. The reactive chain

primarily ends via radical recombination (equations (39) and (40)):



**6.2.3 Oxysulphur radicals mechanism—radical termination phase.** Equations (27), (28) and (32–40) represent the core, simplified elementary reactions in the oxysulphur radical chain model. They can be easily found in literature [26, 27, 59, 60, 66, 114, 210]. In reality, each reaction may proceed with the reactants in combinations of protonated or deprotonated form. It is important to realize the kinetics can be very different for protonated vs deprotonated reactants (see C1 to C5 in Appendix C).

**6.2.4 Oxysulphur radicals mechanism—additional reactions.** Hoffmann and Jacob [112] suggested three more reactions to reinforce the formation of dithionate (equations (41)–(43)).

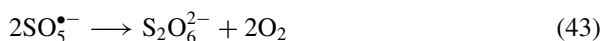
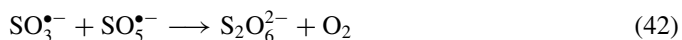

$\bullet\text{OH}$  generation during the propagation phase (equation (44)), its role in Fe(III) regeneration (equation (45)), as well as Fe(III) by  $\text{SO}_3^{\bullet-}$  (equation (46)), have been considered by Brandt *et al.* [114].

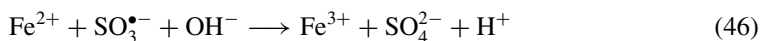
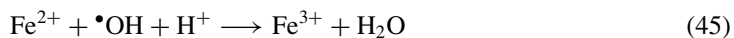
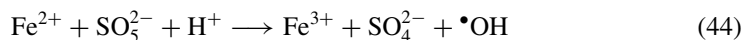

Based upon the discovery of  $\text{S}_2\text{O}_7^{2-}$  formation in non-catalytic S(IV) oxidation by Chang *et al.* [120], Connick *et al.* [121, 216] reported the extent of  $\text{S}_2\text{O}_7^{2-}$  production by titration technique. They believed as much as 90% of sulphate form via equation (40) came from  $\text{S}_2\text{O}_7^{2-}$  hydrolysis [216], and that it was an important S(VI) intermediate in non-catalytic oxidation of S(IV). The following scheme involving  $\text{S}_2\text{O}_7^{2-}$  was suggested (equations (47)–(50)) [216, 217]:

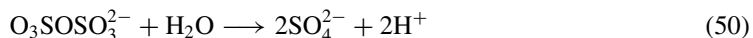
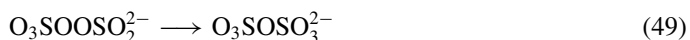
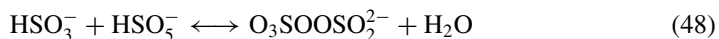
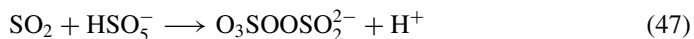

**6.2.5 Oxysulphur radicals mechanism—other variations.** Variation on the oxysulphur radicals chain mechanism can be found. For instance, Karraker [212] proposed a mechanism involving  $\text{SO}_3^{\bullet-}$  and  $\text{H}_2\text{O}_2$ .



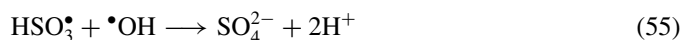
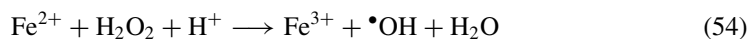
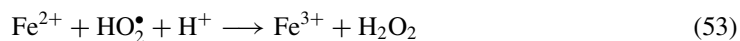

According to the mechanism, Fe(III) was regenerated by Fenton's reaction (equations (53) and (54)) [218], while equations (52) and (55) were the two paths for sulphate production. Equation (55) is likely to be insignificant, because  $\bullet\text{OH}$  production from equation (54) is rather slow ( $k \sim 60 \text{ M}^{-1}\text{s}^{-1}$ , see C4 in Appendix C), and both  $[\text{HSO}_3^\bullet]$  and  $[\bullet\text{OH}]$  are expected to be very low. Equation (52) can be re-expressed essentially as the formation of  $\text{SO}_5^{2-}$  and its hydrolytic decay into sulphate and  $\text{HO}_2^\bullet$ . Based on kinetic considerations, this mechanism seems to be, at best, a minor one in comparison to the classical oxysulphur radicals pathway.

### 6.3 Fe-sulphito complex mediated mechanisms

This mechanism suggests that transfer of electrons is facilitated in the presence of Fe-sulphito complexes. In the context of Fe-S(IV)-O<sub>2</sub> redox chemistry, S(IV) oxidation proceeds in the Fe-bound form, where two electrons are shuttled from S(IV) to oxygen through inner-sphere transfer. Oxysulphur radicals and intermediates are absent in this mechanism category. However, powerful oxidants such as H<sub>2</sub>O<sub>2</sub> may be produced as a result of the decay of Fe-S(IV) complexes and be responsible for the rapid redox reactions. The earliest proponent for the complex mediated mechanism was Bassett and Parker [154]. It has been adopted by Freiberg [219], Cho [142], Conklin and Hoffmann [72, 136], Kao [220], Kraft *et al.* [73], and Krause [74] to explain kinetic observations in Fe-S(IV)-O<sub>2</sub> or related systems. Due to the absence of a core reaction network, different models would be covered individually.

**6.3.1 Complex mediated mechanism—Fe<sup>III</sup>(HSO<sub>3</sub>)(SO<sub>3</sub>).** Freiberg [219] proposed Fe(HSO<sub>3</sub>)(SO<sub>3</sub>) as the key Fe-sulphito complex in the rate determining step of S(IV) autoxidation (equations (56)–(59)).

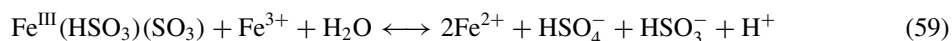
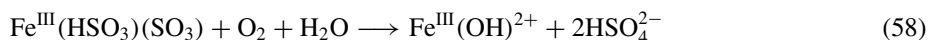
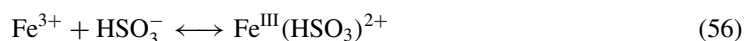

Equations (58) and (59) are each likely to be the stoichiometric representation of two or more elementary reactions. In equation (58), for example, the complex probably first forms an adduct with O<sub>2</sub>, then goes through a number of electron transfer steps, and finally hydrolyzes a water molecule. Unfortunately, the mechanism is incomplete because the regeneration of Fe(III) was not accounted for.

Cho [142] modified the mechanism proposed by Freiberg to obtain better modelling of experimental data. After Fe<sup>III</sup>(HSO<sub>3</sub>)(SO<sub>3</sub>) was formed (equation (57)), three additional pathways for S(IV) oxidation were proposed (equations (60)–(62)):

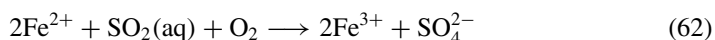
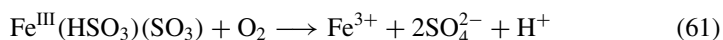
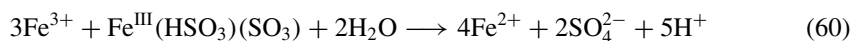



Again, equation (62) is likely to consist of more elementary steps involving formation of mono- or di-nuclear Fe(II)-S(IV) complexes and electron transfer steps.

**6.3.2 Complex mediated mechanism— $\text{HOFe}^{\text{III}}\text{OS}^{\text{IV}}\text{O}_2$ .** Conklin and Hoffmann [136] proposed a complex-based mechanism in which the  $\text{HOFe}^{\text{III}}(\text{O}_2^{\bullet-})\text{OS}^{\text{V}}\text{O}_2$  formation was the rate determining step. The Fe(II)-S(V) complex, which was believed to be orange in colour, decayed upon contact with oxygen. S(VI) oxidation could take place through three pathways, including the oxidation by  $\text{H}_2\text{O}_2$  (equations (63)–(70)).

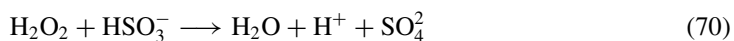
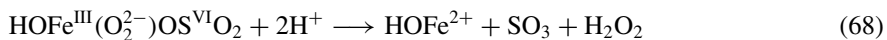
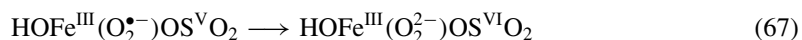
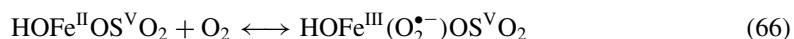

The electron transfer step which results in  $\text{Fe}^{\text{II}}\text{S}^{\text{V}}$  formation (equations (65)) was estimated to have a forward rate constant of about  $0.04 \text{ s}^{-1}$ .

**6.3.3 Complex mediated mechanism— $[\text{Fe}^{\text{III}}\text{SO}_3\text{Fe}^{\text{II}}]^{3+}$ .** Krause [74] proposed a complex-mediated mechanism in which the oxidation of a mixed valence Fe-S(IV) complex was the rate determining step (equations (71)–(74)).

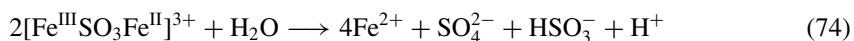
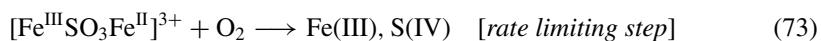
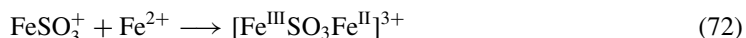
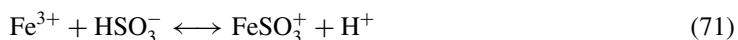

Under oxic conditions Fe(II) and S(IV) would be oxidised according to equation (73). When oxygen is limiting, the complex would decay as equation (74).

**6.3.4 Complex mediated mechanism— $[\text{Fe}^{\text{III}}(\text{SO}_3)_2]^-$ .** Based on the work of Joshi *et al.* [221], Kraft *et al.* [73] endorsed a complex mechanism with  $[\text{Fe}^{\text{III}}(\text{SO}_3)_2]^-$  as the precursor species for subsequent intra-complex oxidation (equations (75)–(80)).

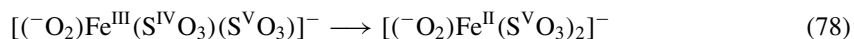
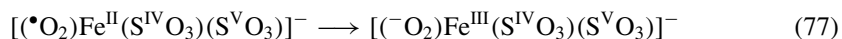
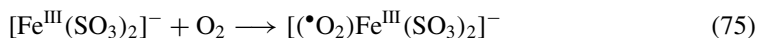

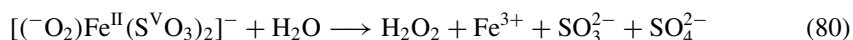
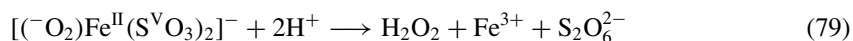

The formation of an oxo-sulphito complex (equation (75)) was suggested based on the observation of O<sub>2</sub> influencing the Fe-S(IV) absorbance signal prior to the decay phase (phase II in section 5.1.2). Further kinetic and entropic analysis on the decay phase suggested the existence of a relatively well-structured species in agreement with the Fe-sulphito superoxo complex. It was also consistent with the finding of Miksztal *et al.* [222], who demonstrated the mononuclear Fe<sup>III</sup>-porphyrin peroxo complex, FeP(O<sub>2</sub><sup>-</sup>), was capable of oxidizing S(IV) to form sulphate or sulphito complexes. Equation (79) was proposed to account for the production of dithionate in the presence of O<sub>2</sub>.

#### 6.4 Mixed mechanisms

Huss *et al.* [150] and Martin *et al.* [67] took a more inclusive approach and suggested that both the oxysulphur radical chain mechanism and the metal-sulphito complex mediated model were at work in different pH regimes. This hypothesis was primarily motivated by their observations of an inhibition effect of organic molecules on S(IV) auto-oxidation [116] and the fact that either mechanism cannot explain kinetic data in a wide pH range [67].

The main evidence for the radicals based mechanism has been the observation of inhibition effect in the presence of organic compounds that are known as radical scavengers (section 5.4). Huss *et al.* [150] suggested that both the radical and the complex-mediated mechanisms were important for Fe(II)-catalyzed oxidation. Lim *et al.* [116] carried out a comprehensive investigation on the inhibition effect of radical scavengers on S(IV) oxidation catalyzed by Mn(II), Fe(II) and Cu(II). They found Mn(II) catalysis was greatly inhibited in the presence of radical scavengers, whereas Fe(II) catalysis was only moderately affected. From this they concluded that the Mn(II) catalysis was essentially mediated via a free-radical chain mechanism, while the Fe(II) catalyzed reaction proceeded through both the radical based and the non-radical based mechanisms. Furthermore, they pointed out radical scavengers could also be oxidised by molecular oxygen, and in the case of hydroquinone, it was mostly oxidised by oxygen rather than by sulphur oxides radicals.

Martin *et al.* [67] studied the Fe(III)-catalyzed S(IV) oxidation. They found that non-complexing organic molecules only significantly inhibited S(IV) auto-oxidation at pH > 5, but not at pH < 3. This was explained in terms of different mechanism prevailing in different pH regimes. They showed that kinetic data at pH > 5 fitted well into a modified radical model. At pH < 3, the kinetic observations including particular phenomena such as self-inhibition, sulphate inhibition and ionic strength effect, however, were in agreement with the predictions based on the complex-mediated mechanism. It should be noted that most organic substrates are in the protonated form at low pH [80], and hence have a weak inhibiting effect.

#### 6.5 Support for each mechanism

**6.5.1 Evidence for oxysulphur radical chain mechanism.** There is supportive evidence for the radicals based mechanism. The mechanism is able to explain the rapid catalytic oxidation in the Fe-S(IV)-O<sub>2</sub> system, how both S(IV) and Fe(II) can be oxidised, and how Fe(III) may be regenerated. The mechanism is consistent with the observation of the inhibition effect in the presence of organic radical scavengers [48, 49, 161, 162, 176, 178, 179]. Finally, the mechanism is able to explain the existence of oxysulphur radicals as proven by pulse radiolysis [52, 55] and electron spin resonance [223–225] studies. Thus, all the criteria mentioned in the beginning of this chapter are well met.

**6.5.2 Evidence for Fe-S(IV) complex-mediated mechanism.** There is supporting evidence for the complex-based mechanism. Model variations such as that described in sections 6.3.2 and 6.3.4 can explain the catalytic oxidation behaviour, including key observations such as Fe(III) regeneration, oxygen as the ultimate electron acceptor. Furthermore, the two models proposed by Conklin *et al.* [136] and Kraft *et al.* [73] were strongly supported by spectroscopic observations, and that the Fe-peroxo structures are confirmed, realistic structures [88, 89, 91, 222].

**6.5.3 Comparative discussion on the radical and complex-mediated mechanisms.** In both mechanisms, the formation of Fe(III)-S(IV) complexes and the subsequent decomposition are regarded as the key reaction steps. The main disagreement has been how oxygen becomes redox-active through the subsequent transformation steps.

The radical mechanism is superior in that the intrinsic rates of most of the involved reaction steps have been measured [27, 56, 59, 215] and have been used in large scale atmospheric chemistry modeling studies [56, 69, 70]. Recently, Buxton *et al.* [52, 53] estimated the intrinsic rates for oxidation of Fe(II) by  $\text{SO}_3^{\bullet-}$  and  $\text{SO}_4^{\bullet-}$ , unprecedentedly distinguishing the forward formation rate of  $[\text{Fe}^{\text{II}}\text{SO}_3^{\bullet-}]^-$  complex, the intra-complex electron transfer rate, and the overall 2nd order rate constant (see C4 in Appendix C). These findings along with the results from inhibition studies, quite convincingly ascertain the oxysulphur-radicals pathway as a valid mechanism for Fe(III) catalyzed S(IV) auto-oxidation in atmospheric systems, where UV radiation and other reactive oxidants such as  $\bullet\text{OH}$  and  $\text{H}_2\text{O}_2$  are highly abundant.

However, this does not imply the oxysulphur radical mechanism also prevails under energetically moderate conditions. In laboratory dark-phase studies and industrial processes such as flue gas desulphurization where UV irradiation and highly reactive oxidative species are all absent, the validity of oxysulphur radicals mechanism is highly questionable (see section 7.2).

For biochemical phenomena such as S(IV) induced DNA damages, the argument for complex-mediated mechanism should be strong because the role of Fe-peroxo complexes in vital biological structures such as hemoglobin and cytochrome is well established [88, 91, 89].

In cases where large chelators such as tetrasulphphthalocyanine (TSP) are present, S(IV) auto-oxidation via the radical path seems unlikely. Tetra- and penta-coordinated Fe(II) complexes are capable of carrying dioxygen in aqueous system [226, 227]. Boyce *et al.* [77] observed no dithionate ( $\text{S}_2\text{O}_6^{2-}$ ) formation and insignificant inhibition with addition of mannitol (radical scavenger) in S(IV) oxidation catalyzed by Me-TSP complexes.

Conklin *et al.* [136] successfully developed, in *a priori* without any fitting parameters, a kinetic expression and rate constant that matched kinetic data observed from four other studies, covering pH from  $\sim 1.5$  to  $>6$ . They also argued that the kinetic expressions in other studies often conformed poorly to the general expression derived based on radical model [112, 208], in particular the reaction order of specific reactant. Furthermore, although the formation kinetics of Fe(III)-S(IV) complexes has no  $\text{O}_2$  dependence [45, 73], the decay kinetics can be influenced by its presence [73]. In the radical model, the formation of  $\text{SO}_3^{\bullet-}$  from  $\text{FeSO}_3^+$  is the rate limiting step in S(IV) auto-oxidation, which  $\text{O}_2$  is neither involved with nor limiting (for  $\text{SO}_3^{\bullet-} + \text{O}_2 \rightarrow \text{SO}_5^{\bullet-}$ ,  $k \sim 10^9 \text{ M}^{-1} \text{ s}^{-1}$ ).

## 6.6 Fe-S(IV)- $\text{O}_2$ in the context of natural processes and engineered systems (scheme 4)

**6.6.1 Activated carbon catalyzed S(IV) oxidation.** A number of studies have looked into S(IV) oxidation catalyzed by activated carbon (AC) slurries [14, 228–230]. In the 1970's, Komiyama *et al.* [230] reported accelerated  $\text{SO}_2$  oxidation in AC slurries. Fu *et al.* [228] compared the S(IV) oxidation catalyzed by AC (heterogeneous) and by Co(II) (homogeneous),

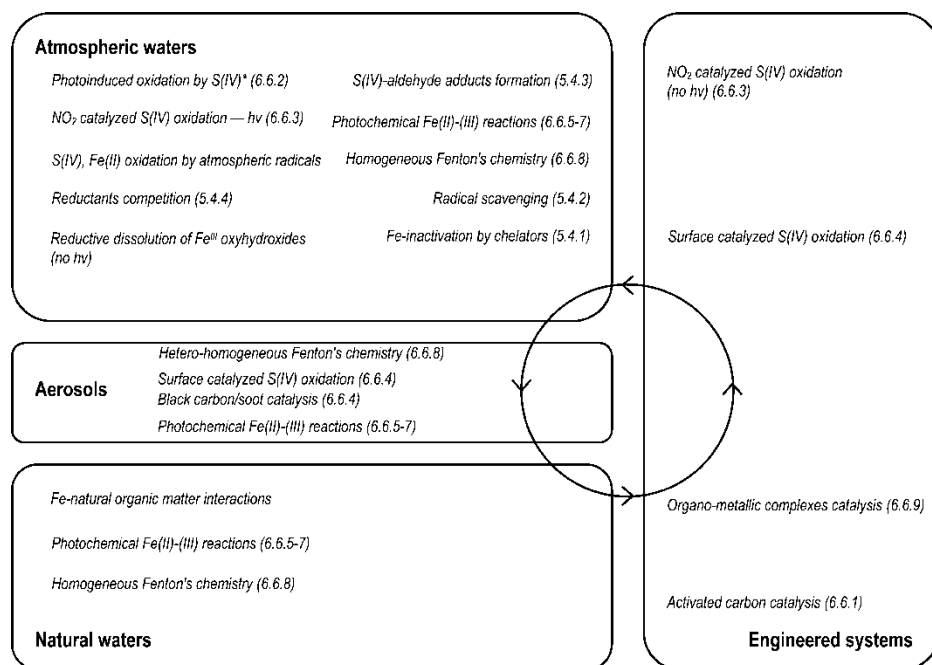
SCHEME 4 Fe-S(IV)-O<sub>2</sub> in the context of natural processes and engineered systems.

and found that in the low pH regime ( $\sim 2-3$ ), the heterogeneous catalysis dominated, while the homogeneous catalysis took over at pH 7–8. The rate determining step was suggested to be the exchange reaction between adsorbed O<sub>2</sub> and S(IV).

Govindarao *et al.* [229] proposed a mechanism for AC catalytic S(IV) oxidation in low pH regime. They suggested that HSO<sub>3</sub><sup>-</sup> and H<sub>2</sub>O•SO<sub>2</sub> competed for surface catalytic sites. While the former reacted with O<sub>2</sub> to form sulphate, the latter simply occupied the site without any further reaction. The activation energy for AC catalytic S(IV) oxidation was estimated to be 96 kJ mol<sup>-1</sup>, while that for deactivation by H<sub>2</sub>O•SO<sub>2</sub> was about 21 kJ mol<sup>-1</sup>.

In a recent investigation, Vidal *et al.* [14] indicated that the Fe content in AC is  $\leq 0.1\%$ . Considering the report of Fe catalysis at  $\sim 10^{-8}$  M [60, 141], 0.1% of Fe would be sufficient to promote S(IV) oxidation. Unfortunately, there has been no effort in determining how much of the AC catalysis is due to the transition metals in the AC. Neither has there been any attempt to explain how AC mechanistically interacts with S(IV) to enhance its oxidation in the presence of O<sub>2</sub>.

**6.6.2 Photochemical oxidation by excited H<sub>2</sub>O•SO<sub>2</sub>.** Kerezsi *et al.* [231] recently reported a new oxidation pathway by UV-photosensitized H<sub>2</sub>O•SO<sub>2</sub>. They observed photo-induced, non-catalytic S(IV) and Fe(II) oxidation at pH < 1.0. The rate was found to be independent of O<sub>2</sub> and pH (pH  $\sim 0-1.0$ ), but dependent of light intensity and [S(IV)]. The possibility of sensitized Fe(II) was ruled out because aqueous H<sub>2</sub>O•SO<sub>2</sub> was much more photo-active ( $\sim 5-6$  orders of magnitude) than Fe(II) [55, 144, 231]. To explain the absence of S<sub>2</sub>O<sub>6</sub><sup>2-</sup> and S<sub>2</sub>O<sub>8</sub><sup>2-</sup> and the independence of rate on O<sub>2</sub>, the following non-radical mechanism was proposed (equations (81)–(84)):

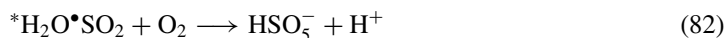
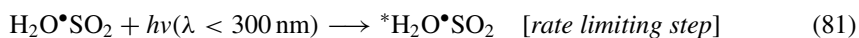

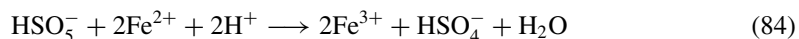
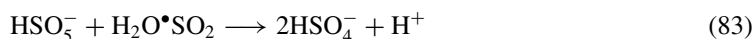

This pathway was expected to be significant at  $\text{pH} < 1.0$  with UV irradiation. Once above  $\text{pH} 1$ , the photo-assisted Fe-catalyzed pathway dominated with increasing  $\text{pH}$ .

**6.6.3  $\text{NO}_x$ -S(IV) interactions.**  $\text{NO}_x$ -S(IV) chemistry is important in atmospheric systems and applications such as flue gas desulphurization [12]. Many interactions and reactions can occur between nitrogen and sulphur oxides. They can form complexes, participate in electron transfer reactions, or form new N-S oxides [232, 233].  $\text{NO}_x$ -S(IV) interactions are sensitive to the presence of  $\text{O}_2$  [135],  $\text{pH}$  [12, 134, 233, 234], and metal catalysts such as Fe ions [235, 236]. Common products of  $\text{NO}_x$ -S(IV) reactions are  $\text{NO}_2^-$ ,  $\text{NO}_3^-$ ,  $\text{SO}_4^{2-}$ ,  $\text{S}_2\text{O}_6^{2-}$  [134], and N-S oxides such as  $\text{HON}(\text{SO}_3)_2^{2-}$ ,  $\text{HONHSO}_3^-$ ,  $\text{HN}(\text{SO}_3)_2^{2-}$ ,  $\text{N}(\text{SO}_3)_2^{2-}$  [234, 237].

$\text{NO}_x$ -S(IV) redox reactions take place primarily at the air-water interface [12].  $\text{NO}_2$  accelerates the dark phase S(IV) oxidation with aerosol by about 10 times [134] via a non-catalytic radical mechanism in which the  $\text{NO}_2$  is not regenerated [233]. Sulphate formation via N-S oxides pathway is significant only at high  $\text{pH}$  ( $>4$ ) [12, 233, 234]

In the presence of Fe-L complexes, N-S interactions can proceed through co-ordination with or without Fe-L complexes, resulting in the oxidation of S(IV) and Fe(II) to S(VI) and Fe(III) [235, 236]. Both non-radical [234, 238] and radical [12, 58, 233] mechanisms have been proposed. The detailed interplay between Fe(II/III),  $\text{NO}_x$ , S(IV), intermediate N-S oxides,  $\text{pH}$ , and other organic substrates is very complicated [235, 236] and is not discussed here.

**6.6.4 Surface catalyzed S(IV) oxidation.** Suspensions of metal oxides such as  $\text{MnO}_2$ ,  $\text{V}_2\text{O}_5$ ,  $\text{Al}_2\text{O}_3$ ,  $\text{TiO}_2$  [239],  $\text{Ni}_2\text{O}_3$ ,  $\text{MgO}$  [240, 241],  $\text{CoO}$ ,  $\text{CuO}$ ,  $\text{SiO}_2$  [127, 242],  $\text{Cu}_2\text{O}$  [126], and  $\text{Fe}_2\text{O}_3$  [71, 239] have been reported to catalyze S(IV) oxidation. Similar effects have also been documented for black carbon and soot [239, 243]. These oxides or particles are ubiquitous in airborne particles [30, 134], combustion residuals, and industrial systems (e.g., mineral slags).

Faust *et al.* [71] investigated  $\text{Fe}_2\text{O}_3$ -catalyzed oxidation of S(IV) in the presence of light. They proposed a mechanism in which S(IV) first became associated with a surface metal site, followed by light absorption and intra-complex electron transfer. The formation of oxidative sulphur oxyanion intermediates is dependent of the configuration of binding (mono-nuclear or bi-nuclear) and the availability of  $\text{O}_2$ . These intermediates are responsible for the oxidation of S(IV) to dithionate or sulphate. An abbreviated model proposed by Faust *et al.* [71] is shown below (equations (85)–(88)):

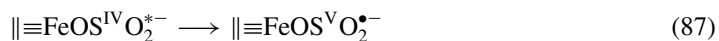
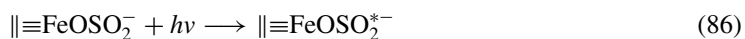
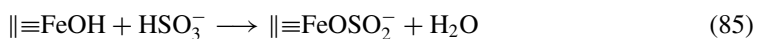

Stumm *et al.* [244] commented that the oxidation of Fe(II) could be sped up when Fe(II) became adsorbed to a surficial hydroxyl group. Thus the catalytic nature involving metal oxides may be two-fold: the surface-assisted production of oxidative intermediates and the adsorption of Fe(II).

Brodzinsky *et al.* [243] studied S(IV) oxidation under soot catalysis. They observed that S(IV) oxidation occurred faster with pre-oxygenated soot and that the activation energy of

the reaction was comparable to that for O<sub>2</sub> chemisorption (~50 kJmol<sup>-1</sup>). From these observations, they suggested that S(IV) oxidation took place when two S(IV) molecules adsorbed onto an oxygenated surface site. A similar mechanism was suggested by Prasad *et al.* [127] for SiO<sub>2</sub> catalysis, except that the bound S(IV) may be oxidised to S<sub>2</sub><sup>VI</sup>O<sub>7</sub><sup>2-</sup> or S<sup>VIII</sup>O<sub>5</sub><sup>2-</sup>.

**6.6.5 Photochemical oxidation of Fe(II) in the absence of O<sub>2</sub> and other reductants.** In the absence of O<sub>2</sub> and other reductants, Fe(III) and molecular H<sub>2</sub> can be produced from UV-induced oxidation of Fe(II) [245]. This may be further assisted with photosensitized Fe(III) [246–248] (see sections 6.6.6 and 6.6.7). Braterman *et al.* [249] and Jortner *et al.* [246, 247] suggested the following scheme for anoxic photo-oxidation of Fe(II) (equations (89)–(95)):

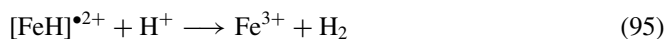
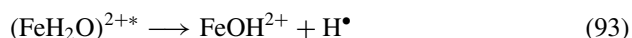
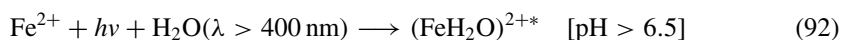
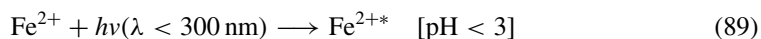

**6.6.6 Fe(III)-mediated photo-oxidation—radical production.** Fe(III) can mediate photo-oxidation of S(IV) or organic substrates in two ways. The first is the production of radicals such as •OH, SO<sub>4</sub><sup>•-</sup> from UV-sensitized Fe(III). The •OH production from FeOH<sup>2+</sup> photolysis has been demonstrated in an early polymerization study [250] and recent decontamination studies [251, 252]. Photolysis of FeOH<sup>2+</sup>/Fe(III) takes place in both UV light and sunlight [253], and is thus an importance source of radicals in atmospheric systems, surface waters, and industrial processes. The radical production reaction from photosensitized Fe(III) may be briefly summarized as follows [246, 247, 250, 254]:



$$(\lambda = 296[254], 313[250] \text{ nm})$$

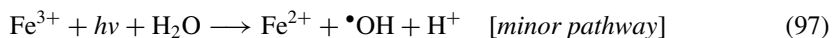

$$(\lambda = 254 \text{ nm}, [250])$$

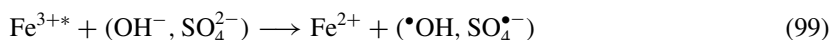

**6.6.7 Fe(III)-mediated photo-oxidation—intramolecular redox reaction.** Fe(III) can also facilitate photo-oxidation of reductive substrate through the formation of a stable Fe<sup>III</sup>-substrate complex. This occurs only when the substrate can form a relatively stable complex with Fe(III). Upon irradiation at an appropriate wavelength, the Fe<sup>III</sup>-substrate complex will absorb light and become sensitized. The complex then undergoes an intramolecular electron transfer [256]. If the substrate binds to Fe(III), it will be photo-oxidised by •OH radicals produced from photo-sensitized Fe(III) [252].

The photo-oxidative path essentially depends upon the electrophilicity of the ligands coordinated to Fe(III) [255]. The ligand that is most willing to donate electron to the Fe(III) center will be oxidised. Thus electron-rich organic ligands will be preferentially oxidised, followed by anions such as  $\text{SO}_4^{2-}$  and  $\text{OH}^-$ . A generic mechanism for the Fe(III)-assisted photo-oxidation of organic molecules is expressed as the following (equations (100)–(102)) [257, 258]:



Zuo *et al.* [258] observed the formation of  $\text{H}_2\text{O}_2$  and the oxidation of S(IV) and dissolved organic matters in the rainwater and fogwater samples exposed to UV and visible light. The photoformation of  $\text{H}_2\text{O}_2$  in the presence of Fe(III),  $\text{O}_2$ , and organic substrates may be expressed as equations (103)–(106) [258]:

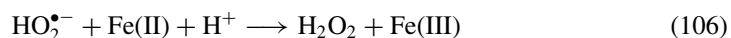
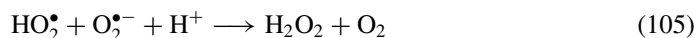
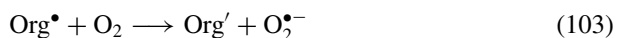

Simple Fe(III) complexes with citrate, oxalate, malonate, pyruvate, glyoxalate [257, 258] and other uncharacterized dissolved organic carbons [42] have been reported to undergo photo-oxidation or to initiate the photoformation of  $\text{H}_2\text{O}_2$ .

**6.6.8 Fenton chemistry and related systems.** In the presence of Fe ions,  $\bullet\text{OH}$  can be produced from  $\text{H}_2\text{O}_2$  (equations (107) and (108)) [218, 259].

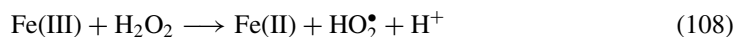

Kwan *et al.* [259] observed similar chemistry with Fe-oxyhydroxides (goethite, ferrihydrite, and hematite) (equations (109)–(111)).

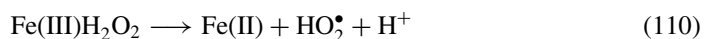
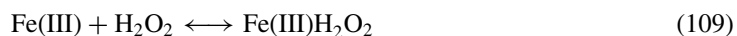

The reactivity of  $\bullet\text{OH}$  is on the same scale or may even exceed those of oxysulphur radicals (see C1 and C4 in Appendix C), and so their presence may not be neglected.

**6.6.9 Fe-organo complexes catalyzed S(IV) oxidation.** The S(IV) oxidation catalyzed Fe(II/III) complexes have been reported.  $\text{Fe}^{\text{II}}$ -tetrasulphphthalocyanine ( $\text{Fe}^{\text{II}}\text{TSP}$ ) [77],  $\text{Fe}^{\text{III}}$ -iminodiacetate ( $\text{Fe}^{\text{III}}\text{IDA}$ ),  $\text{Fe}^{\text{III}}$ -tetraethylenepentamine ( $\text{Fe}^{\text{III}}\text{TH}$ ) [186],  $\text{Fe}^{\text{III}}\text{EDTA}$  [187, 188]  $\text{Fe}^{\text{III}}$ -phenanthroline ( $\text{Fe}^{\text{III}}\text{Phen}$ ) [189] were investigated. Except  $\text{Fe}^{\text{III}}\text{EDTA}$ , all were found to catalyze S(IV) oxidation, though at a rate about  $\sim 10^2$  slower than the uncomplexed Fe(III) catalysis [186].

## 7. Critical review of current thoughts on Fe-S(IV)-O<sub>2</sub> chemistry

### 7.1 Experimental supports for radical chain mechanism

Studies over the past 10 to 15 years favoured the radical chain mechanism for the ‘catalytic’ oxidative feature in Fe-S(IV)-O<sub>2</sub> and other similar systems [26, 27, 60, 66], which is endorsed by several important findings.

The first was the conclusive demonstration of the existence of sulphur oxyanion radicals such as SO<sub>3</sub><sup>•-</sup>, SO<sub>4</sub><sup>•-</sup>, SO<sub>4</sub><sup>•-</sup> by Hayon *et al.* [55] via high-energy photolytic analytical techniques of pulse radiolysis and flash photolysis [193, 260]. Since sulphur oxyanion radicals are the key chemical participants in the radical chain mechanism proposed by Backström, the proof of their existence also substantially validated the chain mechanism. Further radiolysis and photolysis studies were conducted by Buxton *et al.* [59, 261] to quantify the kinetics of reactions between oxysulphur radicals and other ionic, neutral, or radical species. These works demonstrated the high reactivities of SO<sub>X</sub><sup>•-</sup> towards many aqueous species, including S(IV), Fe(II), and O<sub>2</sub>, and also some relatively inert entities such as Cl<sup>-</sup>. At the same time, various studies have shown, without the need of mechanistic speculations, that the formation of Fe(III)-S(IV) complexes (e.g., FeSO<sub>3</sub><sup>+</sup> and Fe(OH)SO<sub>3</sub>H<sup>+</sup>) and their subsequent decomposition determine the overall rate of induced/catalytic redox chemistry in Fe-S(IV)-O<sub>2</sub> system [72, 73, 114, 141, 214]. The highly reactive nature of SO<sub>X</sub><sup>•-</sup> and the fact that it can be generated from the rate determining decay of Fe(III)-S(IV) species via intra-complex electron transfer coupled nicely in support for the radical chain mechanism.

A further indirect support for the chain-mechanism is the inhibition effect exhibited by organic compounds such as benzene [214], phenols [15, 161], simple alcohols [49], and terpenic derivatives [162, 176]. These organic species such as simple alcohols are well known to scavenge radicals in aqueous solutions [58, 193]. The reaction kinetics between these S(IV)-oxidation inhibitors and the key oxysulphur radicals were quantified with either radiolysis/photolysis techniques or decomposition of highly oxidative sulphur-oxide species like S<sub>2</sub>O<sub>8</sub><sup>2-</sup> (see B7 in Appendix B for reduction potential and C4, C6 and C7 in Appendix C for specific reactions). All these findings, again, fit nicely together within the radical chain mechanism framework.

Despite the strong support for the radical mechanism in many recent studies, we have encountered concerns over the popular mechanism in the literature.

### 7.2 Examination on formation of oxysulphur radicals

**7.2.1 Is formation of oxysulphur radicals energetically favourable?** Oxysulphur radicals (SO<sub>X</sub><sup>•-</sup>, X = 3–5) are currently thought to be produced from the redox decomposition of Fe(III)-S(IV) complexes such as FeSO<sub>3</sub><sup>+</sup>. Its production involves an intra-complex single-electron transfer from S(IV) to Fe(III). Here, we will argue that the formation of oxysulphur radicals, in particular SO<sub>3</sub><sup>•-</sup> which is thought to form via the redox-decay of FeSO<sub>3</sub><sup>+</sup>, is thermodynamically unfavourable in the absence of external energy input (e.g., the short wavelength radiation).

The oxidation of Fe(II) by pure oxygen is known to proceed slowly [81], most likely by more reactive species such as singlet oxygen (<sup>1</sup>O<sub>2</sub>). The slow rate is mainly due to the fact that the singlet oxygen concentration in an oxygenated water is low without a high-energy radiation [80]. The ΔE<sub>H</sub><sup>o</sup> for Fe(II) oxidation via <sup>3</sup>O<sub>2</sub> and <sup>1</sup>O<sub>2</sub> to Fe(III) and O<sub>2</sub><sup>•-</sup> are (-0.77 + 0.83 =) 0.06 V and (-0.77 - 0.16 =) -0.93 V, respectively. If we consider the energy difference between the ‘radical’ state (i.e. Fe(III) and O<sub>2</sub><sup>•-</sup>) and the reactant state (i.e. Fe(II) and O<sub>2</sub>),



the  ${}^3\text{O}_2$  path is thermodynamically unfavourable, with a  $\Delta G_{\text{rxn},3-\text{O}_2}^\circ$  of  $90\text{ kJ mol}^{-1}$ —that is, the intrinsic rate of forward reaction ( $\text{Fe(II)}+{}^3\text{O}_2 \rightarrow \text{Fe(III)}+\text{O}_2^{\bullet-}$ ) will be much less than the rate of reverse reaction ( $\text{Fe(III)}+\text{O}_2^{\bullet-} \rightarrow \text{Fe(II)}+{}^3\text{O}_2$ ).

Now, considering the  $\Delta E_{\text{H}}^\circ$  for the formation of Fe(II) and  $\text{SO}_3^{\bullet-}$  from the redox decay of  $\text{Fe}^{\text{III}}\text{SO}_3^+$  and assuming that the energy state of  $\text{Fe}^{\text{III}}\text{SO}_3^+$  is not significantly different from its dissociated form ( $\text{Fe(III)} + \text{SO}_3^{2-}$ ), the  $\Delta E_{\text{H}}^\circ \cong E_{\text{H}}^\circ(\text{Fe}^{3+}/\text{Fe}^{2+}) + E_{\text{H}}^\circ(\text{SO}_3^{2-}/\text{SO}_3^{\bullet-}) = 0.77 - 1.14\text{ V} = -0.37\text{ V}$ , implying a  $\Delta G_{\text{rxn}}^\circ$  of  $36\text{ kJ mol}^{-1} > 0$ . Would the reduction of Fe(III) to Fe(II) be more favourable if S(IV) is oxidised to a non-radical S(V) state instead? If we approximate  $E_{\text{H}}^\circ(\text{S(IV)}/\text{S(V)}_{\text{non-radical}})$  to be about the same as  $E_{\text{H}}^\circ(\text{H}_2\text{SO}_3^{2-}/\text{S}_2\text{O}_6^{2-}, \text{H}^+) = -0.56\text{ V}$ , the corresponding  $\Delta E_{\text{H}}^\circ$  and  $\Delta G_{\text{rxn}}^\circ$  would be  $0.21\text{ V}$  and  $-20\text{ kJ mol}^{-1}$ , respectively. Thus, given the assumptions made, it is thermodynamically more favourable for the partially oxidised S to remain in the Fe(II)-S(V) complex form, until the subsequent redox steps take place.

Although the complex is written as Fe(II)-S(V), it is very probable that, in reality, only partial electron density is transferred from S(IV) to Fe(III), resulting in a  $\text{Fe(III}^{-\delta}\text{)-S(IV}^{+\delta}\text{)}$  complex. The partial transfer of electron density within a complex has been observed and is documented for various Co(II)-complex- $\text{O}_2$  adducts by Tovrog *et al.* [90].  $\text{Fe(III}^{-\delta}\text{)-S(IV}^{+\delta}\text{)}$  is thermodynamically more stable than the dissociated  $\text{SO}_3^{\bullet-}/\text{Fe(II)}$  form. It does not need to sustain unstable electron density (i.e., the unpaired electron on  $\text{SO}_3^{\bullet-}$ ) but still retains the readiness to participate in further redox reactions because of the partial electron transfer.

**7.2.2 Could the Fe(III) induced S(IV) auto-oxidation proceed through a complex mechanism?** Supposing the first electron transfer step ends with the formation of Fe(II)-S(V) (or more accurately  $\text{Fe(III}^{-\delta}\text{)-S(IV}^{+\delta}\text{)}$ ), how may the subsequent steps proceed? What is the spontaneity for each of those steps?

Consider the following scheme:

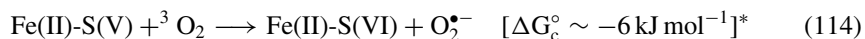
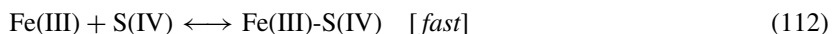

$$^*E_{\text{H}}^\circ(\text{S(V)}_{\text{non-radical}}/\text{S(VI)}) \sim E_{\text{H}}^\circ(\text{S}_2\text{O}_6^{2-}/\text{SO}_4^{2-}, \text{H}^+) = 0.22\text{ V}, \text{ see B7.}$$

The fate of resulting  $\text{O}_2^{\bullet-}$  may be coupled with the regeneration of Fe(III):



\*\*At  $\text{pK}_{\text{a}}(\text{HO}_2^\bullet) = 4.8[259]$ , thus at  $\text{pH} < 4$ ,  $\text{HO}_2^\bullet$  is the predominant form

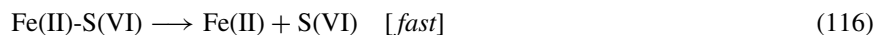

$\text{H}_2\text{O}_2$  is capable of reducing Fe(III) back to Fe(II), but the intrinsic rate for this reaction is much inferior to the oxidation of Fe(II) by  $\text{HO}_2^\bullet$  or by  $\text{H}_2\text{O}_2$ :

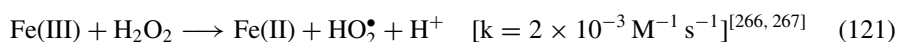
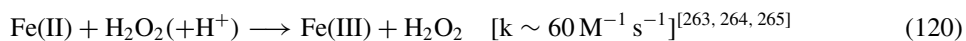
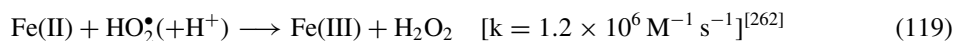

The proposed scheme can explain the key features of Fe-S(IV) induced redox chemistry. It can explain the stepwise oxidation of S(IV) and the regeneration of Fe(III) by O<sub>2</sub>, the ultimate electron acceptor. With the presence of O<sub>2</sub><sup>•-</sup>, it can explain the inhibiting effect of organic molecules on the Fe-catalyzed S(IV) oxidation.

**7.2.3 Would the formation of S-O<sub>2</sub> and Fe-O<sub>2</sub> adducts be possible?** Could an O<sub>2</sub> adduct be formed with an Fe(II)-S(V) complex via a O-S linkage?. SO<sub>3</sub><sup>•-</sup> reacts readily with O<sub>2</sub> to form SO<sub>5</sub><sup>•-</sup>. This reaction is both thermodynamically and kinetically favoured ( $\Delta G_{\text{rxn}}^{\circ} = \Delta G_{\text{f}}^{\circ}(\text{SO}_5^{\bullet-}) - \Delta G_{\text{f}}^{\circ}(\text{SO}_3^{\bullet-}) - \Delta G_{\text{f}}^{\circ}(\text{O}_2) \sim -490 - (-426) = -64 \text{ kJ mol}^{-1}$ ;  $k_{\text{f}} = 1.1 - 2.5 \times 10^9 \text{ M}^{-1} \text{ s}^{-1}$ ) (see B9 in Appendix B and C2 in Appendix C). Supposing the additional stability of complexed S(V) over radical S(V) is about the same as the  $\Delta E_{\text{H}}^{\circ}$  between the  $E_{\text{H}}^{\circ}(\text{S(IV)/S(V)}_{\text{non-radical}})$  and  $E_{\text{H}}^{\circ}(\text{SO}_3^{\bullet-}/\text{SO}_3^{\bullet-})$  couples, the  $\Delta G_{\text{f}}^{\circ}(\text{S(V)}_{\text{non-radical}}) \sim \Delta G_{\text{f}}^{\circ}(\text{SO}_3^{\bullet-}) - nF|\Delta E_{\text{H}}^{\circ}|/1000 = -426 - F(1.14 - 0.56)/1000 = -426 - 56 \cong -480 \text{ kJ mol}^{-1}$  (if estimated as 1/2 of  $\Delta G_{\text{f}}^{\circ}(\text{S}_2\text{O}_6^{2-})$  ( $-1004 \text{ kJ mol}^{-1}$ ),  $\Delta G_{\text{f}}^{\circ}(\text{S(V)}_{\text{non-radical}}) = -502 \text{ kJ mol}^{-1}$ ). Both estimates of  $\Delta G_{\text{f}}^{\circ}(\text{S(V)}_{\text{non-radical}})$  ( $-480$  to  $-500 \text{ kJ mol}^{-1}$ ) are in the vicinity of  $\Delta G_{\text{f}}^{\circ}(\text{SO}_5^{\bullet-})$  ( $-490 \text{ kJ mol}^{-1}$ ), and so the formation of a SO<sub>X</sub>-peroxo adduct by Fe(II) is thermodynamically possible, i.e.:



The remaining structure in the complex may partially stabilize the peroxo-functionality, and should be less reactive than SO<sub>5</sub><sup>•-</sup>. Following reactions may take place in a manner analogous to those with SO<sub>5</sub><sup>•-</sup>:

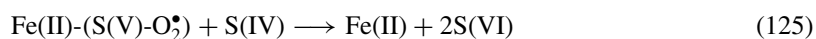
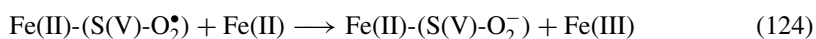

A similar peroxo- adduct may be formed between Fe(III) and O<sub>2</sub> via an Fe-O linkage, i.e. •O<sub>2</sub>-Fe(III)-S(IV), as suggested in Boyce *et al.* [77].

**7.2.4 When would oxysulphur radicals be important?** Radiolysis, photolysis, and induced S<sub>2</sub>O<sub>8</sub><sup>2-</sup> decomposition studies have demonstrated the existence of oxysulphur radicals. Although explicit, direct evidence of oxysulphur radicals in the Fe-S(IV)-O<sub>2</sub> system has been lacking, their existence in the system has often been claimed. There are studies (e.g., [36, 37]) that have quoted the SO<sub>X</sub><sup>•-</sup> radical chain mechanism as the valid model, or even proposed a chain mechanism that catered to their specific cases, without providing any direct or indirect evidence.

Studies that have demonstrated the presence of SO<sub>X</sub><sup>•-</sup> often involves the input of external energy such as UV-vis radiation, addition of highly reactive oxidants such as S<sub>2</sub>O<sub>8</sub><sup>2-</sup>, or employment of catalytic systems working in a combination with oxidative species. The following is a brief summary on when oxysulphur anion radicals have been explicitly observed. With this list, we hope to question the claim about the existence of SO<sub>X</sub><sup>•-</sup> and HSO<sub>5</sub><sup>-</sup>/SO<sub>5</sub><sup>2-</sup> (produced from SO<sub>X</sub><sup>•-</sup>-O<sub>2</sub> reactions) in the Fe-S(IV)-O<sub>2</sub> systems under 'ordinary' conditions (i.e., no irradiation or substantial heating, no initial presence of highly oxidative species.).

Pulse radiolysis and flash photolysis techniques are two of the most common techniques to generate oxysulphur radicals [53–55, 57, 58, 185, 197, 198, 260, 268–272]. Essentially, both techniques bombard an aqueous solution with short wavelength (<300 nm) to induce the formation of radicals. For example, in radiolysis,  $\mu$  sec-pulses of photons generated at  $\sim 2$ –10 MeV [54, 55, 57] are shone onto the test solution. Following reactions then take place

[55, 268, 269, 272]:

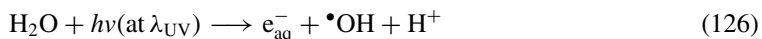

The presence of these radicals was affirmed by absorbance measurement at their characteristic wavelengths.

Sun *et al.* [273] documented the enzymatic production of  $\text{SO}_3^{\bullet-}$  by xanthine oxidase, a human liver enzyme, in the presence of  $\text{H}_2\text{O}_2$ . The enzymatic action reduced the activation barrier toward S(V) radical formation, while the oxidative  $\text{H}_2\text{O}_2(\text{E}_{\text{H}}^{\circ}(\text{H}_2\text{O}_2, \text{H}^+/\text{H}_2\text{O}) = 1.77 \text{ V})$  drove the production of  $\text{SO}_3^{\bullet-}$  from S(IV). It was uncertain if  $\text{SO}_3^{\bullet-}$  was generated in the xanthine oxidase- $\text{O}_2$  combination.

Gilbert *et al.* [201] reported the production of  $\text{SO}_4^{\bullet-}$  from  $\text{S}_2\text{O}_8^{2-}$  induced by transition metal ions such as  $\text{Cu}^{\text{I}}$ ,  $\text{Fe}^{\text{II}}$ ,  $\text{Ti}^{\text{III}}$  (equation (129)), or from  $\text{Ti}^{\text{III}}/\text{Fe}^{\text{II}}\text{-(EDTA/NTA/DTPA)}$  complexes in the presence of  $\text{HSO}_5^-$  (equation (130)).

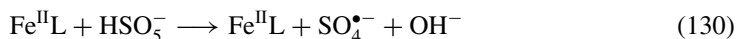
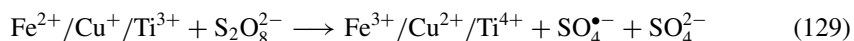

(where L = EDTA, NTA, DTPA)

Fischer *et al.* [144] reported  $\text{SO}_3^{\bullet-}$  formation from  $\text{HSO}_3^-/\text{SO}_3^{2-}$  photodecomposition ( $\lambda > 200 \text{ nm}$ ) in the absence of  $\text{O}_2$  and the eventual formation of sulphate and  $\text{S}_2\text{O}_6^{2-}$ . The  $\text{S}_2\text{O}_6^{2-}$  was formed via  $\text{SO}_3^{\bullet-}$  recombination; sulphate formation in the absence of oxygen was left unexplained. However, sulphate was reported to be produced 'at the expense of dithionate'. This, together with the reaction between  $\text{H}^{\bullet}$  and  $\text{S}_2\text{O}_6^{2-}$  allows us to speculate on the following mechanism for sulphate production:



In the presence of  $\text{O}_2$ , the formation of  $\text{S}_2\text{O}_8^{2-}$  via the recombination reaction of  $\text{SO}_5^{\bullet-}$  was reported.

The sulphate ion radical,  $\text{SO}_4^{\bullet-}$ , can be generated from  $\text{S}_2\text{O}_8^{2-}$  ( $\text{E}_{\text{H}}^{\circ}(\text{S}_2\text{O}_8^{2-}/\text{SO}_4^{\bullet-}) = 2.0 \text{ V}$ ) by photolysis (photoactivation), chemical activation, or thermolysis (thermal decomposition) [274]. Examples of  $\text{SO}_4^{\bullet-}$  production from photolysis ( $\lambda = 248 \text{ nm}$  [275],  $351 \text{ nm}$  [199]) of  $\text{S}_2\text{O}_8^{2-}$  can be found [193, 199, 275, 276]. Transition metal ions such as Au, Co, Cu, Fe, Mn are also known to induce decomposition of  $\text{S}_2\text{O}_8^{2-}$  to  $\text{SO}_4^{\bullet-}$  [274] and refs. within, [277]. The rate of activation can be further enhanced when a relatively reducing oxysulphur anion is present [277] or when the metal ion is chelated [278]. Sulphate ions generated from  $\text{S}_2\text{O}_8^{2-}$  is highly temperature dependent [178, 274] (see also C7 in Appendix C).

Deister *et al.* [38] investigated the photo-oxidation of sulphite/bisulphite at  $\lambda = 254 \text{ nm}$  and claimed the presence of oxysulphur radicals from the inhibitive effect of alcohols on S(IV) oxidation.

Ozawa *et al.* [225] independently found a chemically-induced pathway for  $\text{SO}_3^{\bullet-}$  generation. They were able to generate  $\text{SO}_3^{\bullet-}$  from S(IV) at pH 2.5 in the presence of oxidative  $\text{Ce}^{4+}$  ( $\text{E}_{\text{H}}^{\circ}(\text{Ce}^{4+}/\text{Ce}^{3+}) = 1.72 \text{ V}$ ) (see also  $\Delta\text{E}_{\text{H}}^{\circ}$  for the  $\text{SO}_3^{\bullet-}$  formation from  $\text{SO}_3^{2-}$  and  $\text{Ce}^{4+}$  in table B10 in Appendix B) and at pH 9 in the presence of  $\text{Ti}^{\text{III}}\text{EDTA-H}_2\text{O}_2$ . The presence of the sulphite radical was ascertained by its electron spin resonance signal.

From the above list, it is doubtful that  $\text{SO}_X^{\bullet-}$  radicals can be formed solely from the catalytic action of Fe(III) without radiation or other powerful oxidants (e.g.,  $\text{H}_2\text{O}_2$ ,  $\text{S}_2\text{O}_8^{2-}$ ) which have an  $E_{\text{H,red}}^\circ$  exceeding that of  $\text{O}_2/\text{H}_2\text{O}$  couple. In the case of  $\text{Ce}^{4+}$ , its oxidizing power is comparable with that of  $\text{H}_2\text{O}_2/\text{H}_2\text{O}$  couple. Hence, one may argue about the importance of oxysulphur radicals in atmospheric systems where high-energy radiation and powerful oxidants are plentiful. However, their roles in the ordinary dark Fe-catalysis of S(IV) (or other reductants) oxidation deserve to be questioned and should be further investigated.

### 7.3 Examination on the inhibition of Fe induced S(IV) auto-oxidation

**7.3.1 Are auto-oxidation ‘inhibitors’ simply reductants?** Another piece of evidence that supports the radical chain model is the observed inhibition of S(IV) oxidation (section 5.4; also [26, 66] and refs. within) by those often referred as radical scavengers.

Studies have shown these chemical classes inhibiting catalytic S(IV) oxidation to various extents, but their reductive nature is often ignored during data analysis. Rudzinski [178] studied the effect of isoprene on S(IV) oxidation induced by Mn(II). It was observed that the induction period became longer with a higher level of isoprene. A similar observation was also made by Wolf *et al.* [182] when oxalate was present in an Fe-S(IV)-O<sub>2</sub> system. A prolonged induction period is also observed when the system has relatively high initial  $[\text{Fe(II)}]/[\text{Fe(III)}]$ ,  $[\text{S(IV)}]/[\text{Fe(III)}]$ , or  $\text{SO}_2/\text{O}_2$  ratios (see sections 5.1.1 and 5.2.4). Kulkarni *et al.* [15] have shown a complete degradation of phenol in a Cu-S(IV)-O<sub>2</sub> system. Thus, the inhibitive effect of these organic inhibitors may be simply due to their reductive nature, rather than their particular radical-scavenging properties.

The fact that inhibitors react with  $\text{SO}_X^{\bullet-}$  radicals readily (see C9 in Appendix C) does not necessarily lead to the same radical pathway involved in the Fe-S(IV)-O<sub>2</sub> redox chemistry. Given the observation of slower S(IV) oxidation and prolonged induction period (e.g. [49, 178, 179]) one may only claim that Fe(III) and S(IV) together induce dissolved O<sub>2</sub> to some activated form that can undergo electron transfer reaction readily. Reductants, such as S(IV), organic reductants, and perhaps also reduced metals, will compete with each other to react with the activated form of O<sub>2</sub>. Essentially, Fe(III)-S(IV) interaction serves as a catalytic shuttle for electron transfer between O<sub>2</sub> and aqueous reductants.

The extent of inhibitive effect will depend primarily on the relative abundance of inhibitors to S(IV), and the relative reactivities between the reductants with O<sub>2</sub> in the redox-activated form. Thus, even when the inhibitive effect is ‘significant’ and  $[\text{S(IV)}] \gg [\text{inhibitors}]$ , it may not be concluded that the inhibitive effect is due to the radical quenching, since the possibility of the organic molecules being more reactive reductants than S(IV) exists.

It is rather misleading to call chemical species such as alcohols, phenols, and benzenes as ‘inhibitors’, if they do not deactivate the metal catalyst by complexation, but simply compete with S(IV) as reductants in the metal-catalyzed S(IV)-O<sub>2</sub> system. Ziajka *et al.* [49, 179] studied the effects of terpenic alcohols on S(IV) auto-oxidation under Fe(III) catalysis, and showed that for alcohols and some terpenic derivatives, the inverse of S(IV) oxidation rate was proportional to the amount of competing reductant added. This suggests the decay of terpenic derivatives increases as the rate of S(IV) oxidation decreases. Similar results were also found in [178]. Pasiuk-Bronikowska *et al.* [162] further showed that phenolic species also competed with S(IV) oxidation in non-catalytic system.

### 7.3.2 Can the diminished S(IV) oxidation rate be explained without radical scavengers?

Ziajka *et al.* [49, 179] brought the classical expression on auto-oxidation inhibition kinetics by Alyea *et al.* [1] into the context of a radical chain mechanism, and successfully fitted most

of their experimental data. They first formulated a chain termination rate as a sum of two terms (equation (132)), and then showed, after making some assumptions, that the inverse of S(IV) oxidation rate can be related to the concentration of the inhibitor (here alcohol, 'alc') (equation (133)):

$$r_{\text{term}} = k_1[\text{Fe(II)}][\text{SO}_5^{\bullet-}] + k_2[\text{alc}][\text{SO}_4^{\bullet-}] \quad (132)$$

$$\left\{ \frac{d[\text{S(IV)}]}{dt} \right\}^{-1} = \frac{A + B[\text{S(IV)}]}{[\text{alc}]} \quad (133)$$

where [Fe(II)] and other rate constants condense into A and B. An equation of the same form as (equation (133)) can be obtained if other oxidative intermediates (e.g.,  $\bullet\text{OH}$ ,  $\text{O}_2^{\bullet-}$ , or oxygenated complexes, etc) are used instead of  $\text{SO}_4^{\bullet-}$  and  $\text{SO}_5^{\bullet-}$ . The experimental data may be explained equally well by other oxidative intermediates, and hence a non-oxysulphur radicals chain mechanism may be equally valid.

**7.3.3 Other remarks on inhibitive effects.** Inhibitor studies can be conclusive of the catalytic S(IV) auto-oxidation involving oxysulphur radicals only when the products are strictly due to the presence of oxysulphur radicals and nothing else. While many studies had shown the inhibiting effect of organic compounds and radical scavengers on Fe(II) oxidation or S(IV) oxidation, they rarely characterize the reaction pathway or the end-products of the reactions. [49, 162, 176, 178, 179]. Two particular studies will be commented in this respect as examples.

Kharchenko *et al.* [6] studied  $\text{CN}^-$  oxidation in Cu(II)-S(IV)- $\text{O}_2$ . They tested for the involvement of radical species with acrylonitrile. It was found that polymerization did not occur when  $\text{CN}^-$  was in contact with S(IV)- $\text{O}_2$  only, but acrylonitrile polymerized when Cu(II) was added. The finding was attributed to the formation of  $\text{SO}_3^{\bullet-}$  from Cu(II)-S(IV) electron transfer, with the key oxidation step of  $\text{CN}^-$  proposed to be a three-electron transfer step:



But is this reaction thermodynamically favourable?  $E_{\text{H}}^\circ(\text{CNO}^\bullet/\text{CNO}^-) = 2.66 \text{ V}$  [279], and  $E_{\text{H}}^\circ(\text{CNO}^-, \text{H}_2\text{O}/\text{CN}^-, \text{OH}^-) = 0.97 \text{ V}$  (i.e. (equation (135)), [280]), which gives:  $E_{\text{H}}^\circ(\text{CNO}^\bullet/\text{CN}^-) = 3.63 \text{ V}$  (equations (136) and (137)).



Taking the highest  $E_{\text{H}}^\circ(\text{SO}_5^{\bullet-}/\text{SO}_5^{2-}) \leq 1.4 \text{ V}$  [57] (equation (138)) and  $E_{\text{H}}^\circ(\text{SO}_5^{2-}/\text{SO}_4^{2-}) \sim 1.8 \text{ V}$  (from table B7 in Appendix B) (equation (139)) gives an  $E_{\text{H}}^\circ(\text{SO}_5^{\bullet-}/\text{SO}_4^{2-}) \sim 3.2 \text{ V}$  (equation (140)).

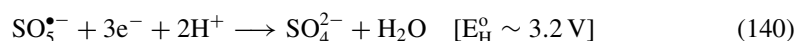
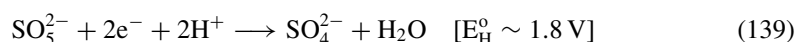

This would give a  $\Delta E_{\text{H}}^\circ$  for reaction (7.6)  $\sim 3.2 \text{ V} - 3.6 \text{ V} = -0.4 \text{ V}$ , implying the reaction is not spontaneous. Furthermore, Kharchenko *et al.* [6] commented that  $\text{CN}^-$  is well known to

reduce free, uncomplexed Cu(II) to produce CN• radical (equation (141)), which may dimerize (equation (142)) or further react to form CNO<sup>-</sup> (equation (143)).

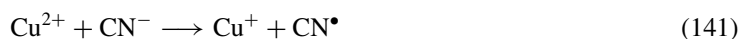

Their data showed that in the absence of Cu(II), CN<sup>-</sup> decayed in the Na<sub>2</sub>SO<sub>3</sub>-Na<sub>2</sub>S<sub>2</sub>O<sub>5</sub> exposed to atmospheric O<sub>2</sub>, noting that S<sub>2</sub>O<sub>5</sub><sup>2-</sup> decomposes to give S(IV). Without characterizing the end-products of CN<sup>-</sup> oxidation, the fate of S(IV) or Cu(II), and even the temperature, it is not clear what had caused the polymerization of acrylonitrile.

The work of Pasiuk-Bronikowska *et al.* [48] gave a stronger evidence for the involvement of oxysulphur radicals in the Fe(III)-S(IV)-O<sub>2</sub> system. They investigated toluene, naphthalene, paraffin oil sulphonation in the Fe(III)/Mn(II)/Co(II)-S(IV)-O<sub>2</sub> systems. Their HPLC analysis demonstrated the formation of sulphonated toluenes and naphthalenes over time, which, they concluded, were formed from the recombination of organo-radical and SO<sub>3</sub><sup>-</sup> radical.

Their proposed reaction is not consistent with the classical SO<sub>x</sub><sup>-</sup> chain model. In the classical model, SO<sub>3</sub><sup>-</sup> preferentially combines with O<sub>2</sub> to form the highly oxidative SO<sub>5</sub><sup>-</sup>, which is the key chain-branching radical [66]. The formation of SO<sub>5</sub><sup>-</sup> from SO<sub>3</sub><sup>-</sup> and O<sub>2</sub> is also spontaneous ( $\Delta G_{\text{rxn}}^\circ \sim -60 \text{ kJmol}^{-1}$ , from B9 in Appendix B). Thus it is unlikely to have free floating SO<sub>3</sub><sup>-</sup> radicals encountering an aromatic radical, as SO<sub>3</sub><sup>-</sup> radicals are much less available than O<sub>2</sub>. Given that their experiments were conducted at temperature ranging from 53 to 90 °C, the sulphonated organics observed likely come from the direct sulphonation reaction between S(IV) and the aromatics. The sulphonation of aromatic compounds is rather well documented [281], and the removal of water or heating are known to promote sulphonation. Unfortunately, no control experiments were reported for a background sulphonation signal from a S(IV)-organic substrate-only system [48]. In addition, the timescale of the reaction (4–8 hrs) sharply contrasts the typical lifetime of the Fe-S(IV)-O<sub>2</sub>-inhibitors reaction, 5–20 mins as in [178, 49].

Although the oxidation of benzene to phenol has been demonstrated in the Fe-S(IV)-O<sub>2</sub> system by Deister *et al.* [38] and Travina *et al.* [163], the results were not conclusive on the involvement of oxysulphur radicals because photolysis and powerful oxidants were used (see section 7.2.4).

Not all reported inhibition effects are attributed to radical scavenging. For instance, Krause [74] reported an inhibition effect by thiourea (H<sub>2</sub>NCSNH<sub>2</sub>) and thiocyanide (SCN<sup>-</sup>). Having a similar structure as aldehydes, thiourea may form an adduct with S(IV); thiocyanide, on the other hand, probably inactivates the Fe center via complexation. The report of possible interference of O<sub>2</sub> on the radical-scavenging of hydroquinone [150] also cast doubts on the oxysulphur radical pathway being the only viable model for the catalytic S(IV) or Fe(II) oxidation.

## 8. Discrepancies and difficulties

### 8.1 Disagreement and discrepancies

**8.1.1 Nature of non-catalytic S(IV) oxidation.** There seem contrasting views on the existence of uncatalyzed S(IV) oxidation, mainly due to the fact that the contamination by trace metal ions is difficult to eliminate [43, 132]. Studies showed that as little as  $\sim 10^{-8}$  M of

Fe(III) is sufficient to initiate S(IV) oxidation [51, 282] and small quantities of strong chelating agents such as EDTA and phenanthroline could also stop the reaction [76, 116, 185, 189]. Ermakov and Purmal [60] pointed out that the residual  $[\text{Fe}]_{\text{Tot}}$  in typical deionized waters was about  $2\text{--}50 \times 10^{-8}$  M and the estimated trace Fe in typical non-catalytic studies ranged from  $3\text{--}20 \times 10^{-9}$  M. Based on these estimates and the fact that the trace contamination is hard to avoid, they suggested that there was no truly non-catalytic S(IV) oxidation. The S(IV) oxidation observed in all cases was suggested to be due to trace Fe ions present in the system. They even argued that the reported catalysis by other transition metal ions in low valence states (e.g., Mn(II), Fe(II)) was all initiated by trace Fe(III) in the system.

The potential importance of trace metal was not accepted or recognized by others [38, 114, 121, 144, 156]. In fact, very few non-catalytic studies have taken sufficient precautions against trace metal contamination: reactors in most studies were made of glass rather than teflon [98]; solutions were predominantly prepared from deionized water rather than double- or triple-distilled water. Other sources of uncertainty are inadequate cleaning procedure, not using gaseous  $\text{SO}_2$  as the S(IV) source and impurities in stock chemicals such as buffering agents or concentrated acid.

**8.1.2 Reaction order and its dependence of reactants.** A great variation in the reaction order and its dependence of individual reactants has been reported for the Fe-S(IV)- $\text{O}_2$  and similar systems [26, 77, 112, 160]. Some of the reported inconsistency, for example the varying order dependence upon  $[\text{S(IV)}]$  and  $[\text{O}_2]$  in packed column studies, is probably due to specific reactant(s) being limiting. For systems involving gases, the limiting effect due to slow mass transfer can also be important [229, 230]. For instance, Brandt *et al.* [94] observed that the rate of S(IV) auto-oxidation had an  $\text{O}_2$  dependence at pH 2.5 but not at pH 6.1. This can be explained from the general trend that S(IV) oxidation rate declines dramatically as pH moves away from the optimal range of  $\sim 3$  to 5 (section 5.2.5). Others gave mixed-order rate expressions (e.g., [98, 127, 160, 283]) that may be empirically useful but have vague kinetic meanings. In the studies where  $\text{O}_2$  is not limiting, the disagreement on the reaction order for  $[\text{S(IV)}]$  and  $[\text{Fe(II/III)}]$  also exists: some proposed a 1.5 order dependence on  $[\text{S(IV)}]$  and 0.5 order on  $[\text{Fe}]$ , while first-order dependence for both  $[\text{S(IV)}]$  and  $[\text{Fe}]$  was adopted in other studies [26, 77, 112]. The reaction order of  $[\text{H}^+]$  also varies greatly [26, 141]. While a part of the inconsistency may be attributed to different mechanistic interpretations in literature (i.e. radical vs complex mechanism) [112, 208], a substantial portion of the disagreement seems rooted in the ignored role of  $[\text{S(IV)}]$  and  $[\text{Fe}]$  speciation. For instance, the explicit  $[\text{H}^+]$  dependence should disappear if individual S(IV) or Fe(III) species are expressed. Only very few studies (e.g., [136]) considered speciation in the kinetic analysis. Furthermore, different forms of Fe(III) and S(IV) behave differently in complexation or redox reactions (B3, B5, C1, etc in the Appendices). Unfortunately, a fundamental concept as such has slipped away from numerous redox kinetic studies on the Fe-S(IV)- $\text{O}_2$  system.

**8.1.3 Catalysis by transition metals at low valence states (Fe(II), Mn(II), etc).** A number of studies have reported S(IV) auto-oxidation catalyzed by low-valence transition metals, such as Fe(II), Mn(II), and Cu(II) [13, 50, 64, 98, 132, 178]. Co(II) and Pb(II) were found to increase S(IV) oxidation rate at pH  $> 6$  [50, 64]. Cr(III), V(IV), and V(V) were reported to have little catalytic activity over the autoxidation of S(IV) [77, 94, 123, 284, 285]. Dasgupta *et al.* [131], however, reported no catalytic effect by Mn(II), Co(II), Ni(II), and As(III).

Ermakov and Purmal [141] showed that production  $\text{SO}_3^{\bullet-}$  from S(IV) with Mn(II) as electron acceptor is thermodynamically unfavourable (see B10 in Appendix B) and claimed

that the ubiquitous Fe(III) were the true catalysts for ‘Mn(II) catalysis’ and catalysis due to other low valence transition metal ions. In the case of Mn(II) catalysis, they claimed, oxidative intermediates (e.g.  $\text{SO}_3^{\bullet-}$ ) formed from Fe(III) catalysis initiated the formation of Mn(III), which was catalytically more effective than Fe(III) itself. This seems to support an observation by Huss *et al.* [150] in which a long induction period was found in the presence of Fe(II) but not Mn(II). The claim of Mn(III) being a better catalyst than Fe(III) is also supported by the measured intrinsic rates ( $\text{Mn(III)} + \text{S(IV)} \rightarrow \text{SO}_3^{\bullet-} + \text{Mn(II)}$ ,  $k \sim 10^6 \text{ M}^{-1} \text{ s}^{-1}$ ;  $\text{Fe(III)} + \text{S(IV)} \rightarrow \text{SO}_3^{\bullet-} + \text{Fe(II)}$ ,  $k \sim 10^{-1} \text{ M}^{-1} \text{ s}^{-1}$ ). Boyce *et al.* [77] studied the S(IV) auto-oxidation with Co(II), Fe(II), Mn(II), Cu(II), Ni(II), and V(IV), chelated by tetrasulphthalocyanine (TSP). They found that S(IV) oxidation proceeded considerably in the case of Co(II)-TSP, followed by Fe(II)-TSP, and Mn(II)-TSP, and no catalytic effect was observed with the complexes of Cu(II), Ni(II), and V(IV).

As a final note, if Ermakov and Purmal’s denial of Mn(II)- $\text{SO}_3^{\bullet-}$  catalysis based on an energetic argument is appropriate, then the Fe(III)- $\text{SO}_3^{\bullet-}$  catalytic pathway, a view which they themselves and many others have firmly endorsed, should likewise be unfavourable (see B10 in Appendix B) in the absence of UV light or powerful oxidants.

## 8.2 Experimental difficulties

**8.2.1 Determining intrinsic rates for radical reactions.** Determining intrinsic rates for reactions involving oxidative oxysulphur radicals and other reactive species has been a challenge for inorganic chemists. Rate constants determined by different groups for the same reaction vary substantially from each other, sometimes by orders of magnitude. For instance, the rate constant for the oxidation of  $\text{HSO}_3^-$  and  $\text{SO}_3^{2-}$  by  $\text{SO}_5^{\bullet-}$  (C1, reaction C1.16 and C1.17–18 in Appendix C) varies from  $10^2$  to  $10^8 \text{ M}^{-1} \text{ s}^{-1}$  and from  $10^4$  to  $10^7 \text{ M}^{-1} \text{ s}^{-1}$ , respectively; the rate constant for the oxidation of  $\text{HSO}_3^-$  by  $\text{HSO}_5^-$  to  $2\text{HSO}_4^-$  ranges from  $10^2$  to  $10^5 \text{ M}^{-1} \text{ s}^{-1}$  (reaction C1.21 in C1 in Appendix C). Das [54] has also highlighted this problem for specific reactions. The orders of magnitude discrepancies in intrinsic rates for key reactions will reduce the credibility of insights derived from pure kinetic analyses, such as those performed in [60, 66, 141].

Oxysulphur radicals reactions are often studied using pulse radiolysis or flash photolysis techniques. Corrections for background reactions are needed, though they are not often performed. For example, following side reactions can take place while generating the desired sulphur oxyanion radicals [54, 185, 271, 272] (equations (144)–(147)):

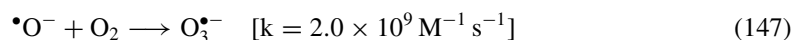
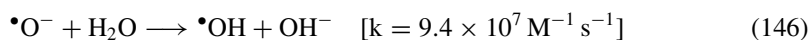
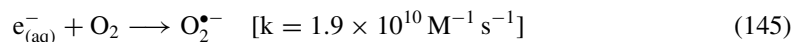
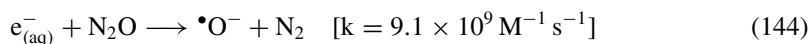

There are also other reactive radicals or species, e.g.,  $\bullet\text{H}$ ,  $\text{HO}_2^\bullet$ ,  $\text{H}_2\text{O}_2$ . Effects due to these reactive species are not insufficiently accounted for in early pulse radiolytic or flash photolytic literature.

**8.2.2 Experimental artifacts due to mass transfer limitation.** Both the oxysulphur radical mechanism and the complex-mediated model suggest that the formation of Fe(III)-S(IV) and its subsequent single electron transfer be the rate limiting step in the entire redox reaction network in aqueous Fe-S(IV)-O<sub>2</sub> system. O<sub>2</sub> is unlikely a limiting factor on the overall



rate when it is relatively abundant compared with Fe or S(IV). Hence the rate expression should have no O<sub>2</sub> dependence. However, mass transfer limitation can be problematic in particular for Fe-SO<sub>2(g)</sub>-O<sub>2(g)</sub> systems. For instance, Tiwari *et al.* [4] found that the rate of Fe(II) oxidation in their system increased with mixing speed, and thus their kinetic data could not be used to establish a reliable rate expression unless interfacial mass transfer parameters were known. This also weakened their subsequent claims on the equilibrium meaning of [Fe<sup>3+</sup>]/[Fe<sup>2+</sup>] ratio and sulphate selectivity. Similarly, the studies by Ferron *et al.* [115] and Zhang *et al.* [39] were likely conducted under O<sub>2</sub>-limiting conditions considering their elevated temperatures and the speed of auto-oxidation. Only very few studies have experimentally verified and eliminated O<sub>2</sub>-limiting conditions (e.g., [74]). Additional considerations and mass exchange performances have to be dealt with [229, 230]. All these bring in extra interpretational difficulties, for example, in kinetic data analysis or the mechanistic role of O<sub>2</sub>.

**8.2.3 Buffer interference.** There is a potential interference on S(IV) auto-oxidation from buffering agents. Drexler *et al.* [286] investigated S(IV) oxidation by peroxy-species in an acidic regime and obtained a rate expression that depended on the buffer type (chloroacetic acid, formic acid, acetic acid, and H<sub>2</sub>PO<sub>4</sub><sup>-</sup>) and concentration. Ramdon *et al.* [287] observed that Cr(VI)-catalyzed S(IV) oxidation increased with the concentrations of phosphate and citrate in an acidic range. Van Dyke *et al.* [288] also documented that buffers such as Tris, carbonate, HEPES, MES, MOPS could interfere with the redox system involving radicals. They commented that phosphate was the most inert towards •OH. Unfortunately, phosphate is likely to suppress the catalytic activity of Fe(III) via complex formation (log β for Fe<sup>III</sup>HPO<sub>4</sub><sup>+</sup> and Fe<sup>III</sup>H<sub>2</sub>PO<sub>4</sub><sup>2+</sup> ~ 24, comparable to that of Fe<sup>III</sup>EDTA or Fe<sup>III</sup>HEDTA).

**8.2.4 Miscellaneous issues.** Researchers in the field are facing several other challenges. One is the interpretation of absorption spectra of the Fe-S(IV)-O<sub>2</sub> system. Earlier researchers [43, 73, 94, 114, 136] examined absorption spectra of Fe-S(IV) solution to study kinetics of Fe-S(IV) interactions. However, these studies did not quantitatively distinguish the contributions from various Fe complexes to the spectra. More recently, Lente *et al.* [45] adopted a more vigorous approach towards the problem. The number of light absorbing species and their relative contribution at specific emission wavelengths were determined by performing matrix rank analysis on the time-resolved spectra.

Several studies have attempted to understand the redox chemistry in the Fe-S(IV)-O<sub>2</sub> system via ‘similar’ systems. They started with Fe(III), O<sub>2</sub>, and powerful oxysulphur oxidants such as HSO<sub>5</sub><sup>-</sup> and S<sub>2</sub>O<sub>8</sub><sup>2-</sup>, and tried to extend the observations from these systems to Fe-S(IV)-O<sub>2</sub> [163, 216]. These systems are substantially different from the Fe-S(IV)-O<sub>2</sub> system because both HSO<sub>5</sub><sup>-</sup> and S<sub>2</sub>O<sub>8</sub><sup>2-</sup> are much more oxidative than O<sub>2</sub> (see B7, B8 in Appendix B). The complicated chemistry of S<sub>2</sub>O<sub>8</sub><sup>2-</sup> has been partly mentioned in section 7.2.4. It should also be mentioned that under an acidic condition, which is the typical setting for Fe catalytic S(IV) oxidation studies, S<sub>2</sub>O<sub>8</sub><sup>2-</sup> can thermally decompose in the following manner [289] (equations (148)–(150)):

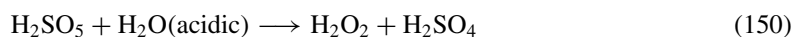
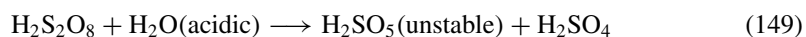
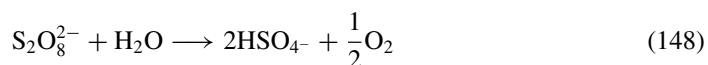

Early in the 1920’s, Mathews *et al.* [290] observed S(IV) auto-oxidation could be further sped up in the presence of UV light. Boyce *et al.* [77] have also shown that even room fluorescent

light was sufficient to enhance the rate of S(IV) auto-oxidation. In the view that both Fe(II) and Fe(III) can get sensitized in the presence of light (section 6.6.5–7), it is crucial to separate the influence of light from the intrinsic chemical behaviour of Fe-S(IV)-O<sub>2</sub> system. However, many previous studies on the system have not stated clearly about the presence or the absence of light.

## 9. Concluding remarks and future works

Recent works have exclusively focused on obtaining rate constants for elementary reactions in the oxysulphur radical reaction network. These intrinsic rates are useful for modeling S(VI)-chemistry in atmospheric systems, but may not be applicable to industrial or engineered systems where radiation or powerful oxidants are absent. The Fe-S(IV)-O<sub>2</sub> system has great potential in applications such as flue gas desulphurization, decontamination, and mineral recovery. Applicational aspects of the system, such as conditions required for complete degradation of organic pollutants, are worth further investigation.

The mechanistic aspect of the Fe-S(IV)-O<sub>2</sub> system, in particular from the perspective of complex-mediated model, needs to be studied. The most recent works by Kraft *et al.* [43, 73] and Conklin *et al.* [44, 72, 136] only touched upon the overall behaviour in the Fe-S(IV)-O<sub>2</sub> system in a complex-based framework. Mechanistic details such as the intrinsic rate and/or equilibrium ratio of the intermediate steps (e.g., the formation of Fe(III)-peroxo linkage, intra-complex Fe(III) regeneration) have not been quantified.

Inhibition studies published so far have failed to document the fate of inhibitors in the Fe-S(IV)-O<sub>2</sub> system in an analytically satisfactory manner. There is still no direct proof for the oxysulphur radicals chain mechanism as the prevailing mechanism in the ordinary (i.e., non-radiated, unamended with powerful oxidants) Fe-S(IV)-O<sub>2</sub> system. More thoughtful experiments are needed to search for this proof or counter-proof.

Very few works have documented the behaviour of E<sub>H</sub> in the Fe-S(IV)-O<sub>2</sub> system. The meaning of the observed hyper-E<sub>H</sub> (>1.3 V), the reasons for its unusually long stability, its relation to specific molecules of species are still unclear. Answers to these questions will provide fundamental insights about this very interesting catalytic system.

## References

- [1] A. Titoff. *Z. Phys. Chem.*, **45**, 641 (1903).
- [2] H.N. Alyea, H.L.J. Bäckström. *J. Am. Chem. Soc.*, **51**, 90 (1929).
- [3] W.P. Jorissen. *Induced Oxidation*, Elsevier, Amsterdam (1959).
- [4] B.L. Tiwari, J. Kolbe, Jr.H.W. Hayden. *Metall. Trans. B*, **10B**, pp. 607 (1979).
- [5] E.A. Devuyt, V.A. Ettel, G.J. Borbely. New Method for Cyanide Destruction in Gold Mill Effluents and Tailing Slurries, paper presented at the 14<sup>th</sup> Ann. Operators Conf. of Can. Min. Proc. Div. of CIM, Ottawa (1982).
- [6] D.V. Kharchenko, I.A. Agapov, N.V. Vorob'ev-Desyatovskii. *Russ. J. Appl. Chem.*, **74**, 1509 (2001).
- [7] R.W. Adams, I.G. Matthew. Leaching of Metal Sulphide Concentrates at Atmospheric Pressure Using SO<sub>2</sub>/O<sub>2</sub> Mixtures, paper presented at Proc. Australas. Inst. Min. Metall., No. 280, December, pp. 41–53 (1981).
- [8] I.B. Ahmed, P.L. Gbor, C.Q. Jia. *Can. J. Chem. Eng.*, **80**, 410 (2002).
- [9] P.K. Gbor, I.B. Ahmed, C.Q. Jia. *Ind. Eng. Chem. Res.*, **41**, 1861 (2002).
- [10] P.K. Gbor, S. Hoque, C.Q. Jia. *Hydrometallurgy*, **81**, 130 (2006).
- [11] R.K. Ulrich, G.T. Rochelle, R.E. Prado. *Chem. Eng. Sci.*, **41**, 2183 (1986).
- [12] C.H. Shen, G.T. Rochelle. *Environ. Sci. Technol.*, **32**, 1994 (1998).
- [13] D. Karatza, M. Prisciandaro, A. Lancia, D. Musmarra. *Ind. Eng. Chem. Res.*, **43**, 4876 (2004).
- [14] F. Vidal, P. Ollero, F.J.G. Ortiz, R. Arjona. *Environ. Sci. Technol.*, **39**, 5031 (2005).
- [15] U.S. Kulkarni, S.G. Dixit. *Ind. Eng. Chem. Res.*, **30**, 1916 (1991).
- [16] B.L. Wedzicha, O. Lamikanra, J.C. Herrera, S. Panahi. *Food Chem.*, **15**, 141 (1984).
- [17] D.S. Khurdiya. *J. Food Sci. Technol. Mysore*, **32**, 441 (1995).
- [18] B.L. Wedzicha, O. Lamikanra. *Food Chem.*, **23**, 193 (1987).
- [19] S.F. Yang. *Food Chem.*, **15**, 113 (1984).

- [20] R.F. McFeeters, L.M. Barrangou, A.O. Barish, S.S. Morrison. *J. Agric. Food Chem.*, **52**, 4554 (2004).
- [21] Q. Wang, G.P. Demopoulos, G.B. Harris. *Waste Processing and Recycling in Mineral and Metallurgical Industries. III*. Proceedings of the 3rd International symposium on waste processing and recycling in mineral and metallurgical industries – Calgary, Alberta, 16–19 August, p. 375 (1998).
- [22] W. Zhang, P. Singh, D. Muir. *Minor Elements*, 333 (2000).
- [23] T.E. Graedel, C.J. Weschler, M.L. Mandich. *Nature*, **317**, 240 (1985).
- [24] D.J. Jacob, E.W. Gottlieb, M.J. Prather. *J. Geophys. Res.*, **94**, 12975 (1989).
- [25] P. Behra, L. Sigg. *Nature*, **344**(6265), 419 (1990).
- [26] C. Brandt, R. van Eldik. *Chem. Rev.*, **95**, 119 (1995).
- [27] H. Herrmann. *Chem. Rev.*, **103**, 4691 (2003).
- [28] G. Zhuang, Z. Yi, R.A. Duce, P.R. Brown. *Nature*, **355**(6360), 537 (1992).
- [29] S.M. Turner, P.D. Nightingale, L.J. Spokes, M.I. Liddicoat, P.S. Liss. *Nature*, **383**(6600), 513 (1996).
- [30] G.S. Zhuang, J.H. Guo, H. Yuan, X.Y. Zhang. *Chin. Sci. Bull.*, **48**, 1080 (2003).
- [31] F. Bodéan, P. Baranger, P. Piantone, A. Lassin, M. Azaroual, E. Gaucher, G. Braibant. *Appl. Geochem.*, **19**, 1785 (2004).
- [32] P.C. Singer, W. Stumm. *Science*, **167**, 1121 (1970).
- [33] O. Sivan, Y. Erel, D. Mandler, A. Nishri. *Geochim. Cosmochim. Acta*, **62**, 565 (1998).
- [34] C. Mottley, R.P. Mason, C.F. Chignell, K. Sivarajah, T.E. Eling. *J. Bio. Chem.*, **257**, 5050 (1982).
- [35] X.L. Shi. *J. Inorg. Biochem.*, **56**, 155 (1994).
- [36] R.G.M. Moreno, M.V. Alipázaga, M.H.G. Medeiros, N. Coichev. *J. Chem. Soc., Dalton Trans.*, 1101 (2005).
- [37] J.G. Muller, C.J. Burrows. *Inorg. Chem. Acta*, **275–276**, 314 (1998).
- [38] U. Deister, P. Warneck. *J. Phys. Chem.*, **94**, 2191 (1990).
- [39] W. Zhang, P. Singh, D. Muir. *Hydrometallurgy*, **55**, 229 (2000).
- [40] Y. Zuo, J. Zhan, T. Wu. *J. Atmos. Chem.*, **50**, 195 (2005b).
- [41] Y. Erel, S.O. Pehkonen, M. Hoffmann. *J. Geophys. Res.*, **98**, 18423 (1993).
- [42] Y. Zuo, J. Hoigné. *Science*, **260**, 71 (1993).
- [43] J. Kraft, R. van Eldik. *Inorg. Chem.*, **28**, 2297 (1989).
- [44] M.H. Conklin, M.R. Hoffmann. *Environ. Sci. Technol.*, **22**, 883 (1988).
- [45] G. Lente, I. Fábián. *J. Chem. Soc., Dalton Trans.*, **5**, 778 (2002).
- [46] I. Fábián, G. Gordon. *Inorg. Chem.*, **30**, 3994 (1991).
- [47] G. Lente, I. Fábián. *Inorg. Chem.*, **41**, 1306 (2002).
- [48] W. Pasiuk-Bronikowska, T. Bronikowski, M. Ulejczyk. *Wat. Res.*, **31**, 1767 (1997).
- [49] J. Ziajka, W. Pasiuk-Bronikowska. *Atmos. Environ.*, **37**, 3913 (2003).
- [50] I. Grgić, V. Hudnik, M. Biziak, J. Levec. *Atmos. Environ.*, **25A**, 1591 (1991).
- [51] I. Grgić, G. Bercic. *J. Atmos. Chem.*, **39**, 155 (2001).
- [52] G.V. Buxton, T.N. Malone, G.A. Salmon. *J. Chem. Soc., Faraday Trans.*, **93**, 2893 (1997).
- [53] G.V. Buxton, S. Barlow, S. McGowan, G.A. Salmon, J.E. Williams. *Phys. Chem. Chem. Phys.*, **1**, 3111 (1999).
- [54] T.N. Das. *J. Phys. Chem. A*, **105**, 9142 (2001).
- [55] E. Hayon, A. Treinen, J. Wilf. *J. Am. Chem. Soc.*, **94**, 47 (1972).
- [56] S.J. Waygood, W.J. McElroy. *J. Chem. Soc., Faraday Trans.*, **88**, 1525 (1992).
- [57] T.N. Das, R.E. Huie, P. Neta. *J. Phys. Chem. A*, **103**, 3581 (1999).
- [58] R.E. Huie, P. Neta. *J. Phys. Chem.*, **88**, 5665 (1984).
- [59] G.V. Buxton, G.A. Salmon. *Prog. React. Kinet. Mech.*, **28**, 257 (2003).
- [60] A.N. Ermakov, A.P. Purmal. *Kinet. Catal.*, **42**, 531 (2001).
- [61] I. Fábián, V. Csordas. *Adv. Inorg. Chem.*, **54**, 395 (2003).
- [62] B.C. Faust. In *Aquatic and Surface Photochemistry*, G.R. Helz, R.G. Zepp, D.G. Crosby (Eds.), pp. 3–39, Lewis Publishers/CRC Press, Boca Raton (1994a).
- [63] M.R. Hoffmann, J.G. Calvert. In *The Aqueous Phase Chemistry*, vol. II, EPA-600/3-85/017, U.S. Environmental Protection Agency (1985).
- [64] L.R. Martin. In *SO<sub>2</sub>, NO, and NO<sub>2</sub> Oxidation Mechanisms: Atmospheric Considerations, Acid Precipitation Series*, vol. 3, J.G. Calvert (Ed.), pp. 63–100, Butterworth, Boston (1984).
- [65] H.R. Pezza, C.F.F. Lopes, M.E.V. Suárez-Iha, N. Coichev. *Quimica Nova*, **22**, 529 (1999).
- [66] A.N. Yermakov, A.P. Purmal. *Prog. React. Kinet. Mech.*, **28**, 189 (2003).
- [67] L.R. Martin, M.W. Hill, A.F. Tai, T.W. Good. *J. Geophys. Res. Atmos.*, **96**, 3085 (1991).
- [68] B. Alexander, R.J. Park, D.J. Jacob, Q.B. Li, R.M. Yantosca, J. Savarino, C.C.W. Lee, M.H. Thiemens. *J. Geophys. Res.*, **110**, D10307 (2005).
- [69] H. Herrmann, B. Ervens, H.W. Jacobi, R. Wolke, P. Nowacki, R. Zellner. *J. Atmos. Chem.*, **36**, 231 (2000).
- [70] M. Leriche, D. Voisin, N. Chaumerliac, A. Monod, B. Aumont. *Atmos. Environ.*, **34**, 5015 (2000).
- [71] B.C. Faust, M.R. Hoffmann, D.W. Bahnemann. *J. Phys. Chem.*, **93**, 6371 (1989).
- [72] M.H. Conklin, M.R. Hoffmann. *Environ. Sci. Technol.*, **22**, 891 (1988).
- [73] J. Kraft, R. van Eldik. *Inorg. Chem.*, **28**, 2306 (1989).
- [74] E. Krause. The oxidation of ferrous sulphate solutions. PhD thesis, University of Waterloo, Canada (1988).
- [75] W. Zhang, D. Muir, P. Singh. *Hydrometallurgy*, **58**, 117 (2000).
- [76] J. Berglund, S. Fronaeus, L.I. Elding. *Inorg. Chem.*, **32**, 4527 (1993).
- [77] S.D. Boyce, M.R. Hoffmann, P.A. Hong, L.M. Moberly. *Environ. Sci. Technol.*, **17**, 602 (1983).
- [78] P.W. Atkins, J. de Paula. *Physical chemistry*, Oxford University Press, Oxford (2002).

- [79] F.M.M. Morel, J.G. Hering. *Principles and Applications of Aquatic Chemistry*, Wiley, New York (1993).
- [80] R.P. Schwarzenbach, P.M. Gschwend, D.M. Imboden. *Environmental Organic Chemistry*, Wiley, New York (2003).
- [81] W. Stumm, J.J. Morgan. *Aquatic Chemistry: Chemical Equilibria and Rates in Natural Waters*, Wiley, New York (1996).
- [82] R.A. Marcus, N. Sutin. *Biochim. Biophys. Acta*, **811**, 265 (1985).
- [83] N.V. Blough, R.G. Zepp. In *Active Oxygen in Chemistry*, C. Foote, J. Valentine (Eds.), pp. 280–333, Blackie Academic and Professional, London (1995).
- [84] D.T. Sawyer, D.T. In *Oxygen Complexes and Oxygen Activation by Transition Metals*, pp. 131–148, Plenum Press, New York (1988).
- [85] R.S. Drago, R.H. Beer. *Inorg. Chim. Acta*, **198–200**, 359 (1992).
- [86] K.D. Karlin, Y. Gultneh. *Prog. Inorg. Chem.*, **35**, 219 (1987).
- [87] H. Mimoun. *J. Mol. Catal.*, **7**, 1 (1980).
- [88] F. Basolo, B.M. Hoffmann, J.A. Ibers. *Acc. Chem. Res.*, **8**, 384 (1975).
- [89] J. Schlichting, J. Berendzen, K. Chu, A.M. Stock, S.A. Maves, D.E. Benson, R.M. Sweet, D. Ringe, G.A. Petsko, S.G. Sligar. *Science*, **287**, 1615 (2000).
- [90] B.S. Tovrog, D.J. Kitko, R.S. Drago. *J. Am. Chem. Soc.*, **98**, 5144 (1976).
- [91] J.T. Groves, Y.Z. Han. In *Cytochrome P450, Structure, Mechanism, and Biochemistry*, P.R.O. de Montellano (Ed.), pp. 3–48, Plenum Press, New York (1995).
- [92] M. Ali, S.K. Saha, P. Banerjee. *Bull. Chem. Soc. Jpn.*, **64**, 2497 (1991).
- [93] J.M. Anast, D.W. Margerum. *Inorg. Chem.*, **20**, 2319 (1981).
- [94] C. Brandt, R. van Eldik. *Transition Met. Chem.*, **23**, 667 (1998).
- [95] R.E. Brown, F. Barber. *J. Phys. Chem.*, **99**, 8071 (1995).
- [96] R. van Eldik, G.M. Harris. *Inorg. Chem.*, **19**, 880 (1980).
- [97] M. Schmidt. In *Sulphur, its Significance for Chemistry, for the Geo-, Bio-, and Cosmosphere and Technology, Studies in Inorganic Chemistry*, **5**, pp. 259–276, Elsevier Science Publishers, Amsterdam (1984).
- [98] A. Huss, P.K. Lim, C.A. Eckert. *J. Phys. Chem.*, **86**, 4224 (1982).
- [99] Z. Stuglik, Z.P. Zagorski, Z. Pawel. *Radiat. Phys. Chem.*, **17**, 229 (1981).
- [100] C.M. Flynn. *Chem. Rev.*, **84**, 31 (1984).
- [101] P.H. Hsu, S.E. Ragone. *J. Soil Sci.*, **23**, 17 (1972).
- [102] P.J. Murphy, A.M. Posner, J.P. Quirk. *Aust. J. Soil Res.*, **52**, 229 (1975).
- [103] P.J. Murphy, A.M. Posner, J.P. Quirk. *J. Colloid Interface Sci.*, **56**, 312 (1976).
- [104] J. Dousma, P.L. de Bruyn. *J. Colloid Interface Sci.*, **64**, 154 (1978).
- [105] J. Dousma, P.L. de Bruyn. *J. Colloid Interface Sci.*, **56**, 527 (1976).
- [106] M. Spiro. *Electrochim. Acta*, **24**, 313 (1979).
- [107] S. Gouger, J. Stuehr. *Inorg. Chem.*, **13**, 379 (1974).
- [108] B. Bänisch, P. Martínez, D. Uribe, J. Zuluaga, R. van Eldik. *Inorg. Chem.*, **30**, 4555 (1991).
- [109] D.F. Shriver, P.W. Atkins. *Inorganic chemistry*, Oxford University Press, Oxford (2001).
- [110] S.S. Zumdahl. *Chemical Principles*, Houghton Mifflin Company, Boston (2005).
- [111] J. Veprek-Siska, D.M. Wagnerova, K. Eckschlager. *Collection Czech. Chem. Commun.*, **31**, 1248 (1966).
- [112] M.R. Hoffmann, D.J. Jacob. In *SO<sub>2</sub>, NO, and NO<sub>2</sub> Oxidation Mechanisms: Atmospheric Considerations, Acid Precipitation Series*, vol. 3, J.G. Calvert (Ed.), pp. 101–172, Butterworth, Boston (1984).
- [113] C.J. Weschler, M.L. Mandich, T.E. Graedel. *J. Geophys. Res., D: Atmos.*, **91(D4)**, 5189 (1986).
- [114] C. Brandt, I. Fabian, R. van Eldik. *Inorg. Chem.*, **33**, 687 (1994).
- [115] C.J. Ferron, D.O. Kwateng, P.F. Duby. (1991), Kinetics of the precipitation of Goethite from ferrous sulphate, paper presented at the EPD Congress 91', The Minerals, Metals & Materials Society, pp. 165–177 (1991).
- [116] P.K. Lim, A. Huss, C.A. Eckert. *J. Phys. Chem.*, **86**, 4234 (1982).
- [117] X. Long, W. Li, W. Xiao, W. Yuan. *J. Hazard. Mater.*, **129**, 260 (2006).
- [118] T. Sato, T. Goto, T. Okabe, F. Lawson. *Bull. Chem. Soc. Jpn.*, **57**, 2082 (1984).
- [119] O.F. Zeck, D.W. Carlyle. *Inorg. Chem.*, **13**, 34 (1974).
- [120] S.G. Chang, D. Littlejohn, K.Y. Hu. *Science*, **237**(4816), 756 (1987).
- [121] R.E. Connick, Y.X. Zhang, S. Lee, R. Adamic, P. Chieng. *Inorg. Chem.*, **34**, 4543 (1995).
- [122] W.C.E. Higginson, J.W. Marshall. *J. Chem. Soc.*, 447 (1957).
- [123] I.N. Kuz'minykh, T.B. Bomshtein. *Zh. Priklad. Khim.*, **26**, 3 (1953).
- [124] C. Brandt, R. van Eldik. *Atmos. Environ.*, **31**, 4247 (1997).
- [125] F.H. Pollard, P. Hanson, G. Nickless. *J. Chromatogr.*, **5**, 68 (1961).
- [126] S.V. Manoj, M. Sharma, K.S. Gupta. *Atmos. Environ.*, **33**, 1503 (1999).
- [127] D.S.N. Prasad, A. Rani, K.S. Gupta. *Environ. Sci. Technol.*, **26**, 1361 (1992).
- [128] W.J. Schlitt, J.B. Hiskey, W.G. Pitt. *Transactions of the American Institute of Mining and Metallurgical and Petroleum Engineers Society*, **274**, 2051 (1983).
- [129] H. Bassett, A. Henry. *J. Amer. Chem. Soc.*, pp. 914 (1935).
- [130] D.W. Carlyle, Jr.O.F. Zeck. *Inorg. Chem.*, **12**, 2978 (1973).
- [131] P.K. Dasgupta, P.A. Mitchell, P.W. West. *Atmos. Environ.*, **13**, 775 (1979).
- [132] E.A. Devuyst, A. Mosoiu, E. Krause. In *Hydrometallurgy: Research, Development and Plant Practice*, pp. 391–403, American Institute of Mining, Metallurgical, and Petroleum Engineers, Inc., New York (1982).
- [133] K.B. Reddy, R. van Eldik. *Atmos. Environ.*, **26A**, 661 (1992).

- [134] J. Turšič, I. Grgić. *Atmos. Environ.*, **35**, 3897 (2001).
- [135] J. Turšič, I. Grgić, M. Bizjak. *Atmos. Environ.*, **35**, 97 (2001).
- [136] M.H. Conklin, M.R. Hoffmann. *Environ. Sci. Technol.*, **22**, 899 (1988).
- [137] G. Lente, I. Fábián. *Inorg. Chem.*, **37**, 4204 (1998).
- [138] G. Lente, I. Fábián. *Inorg. Chem.*, **38**, 603 (1999).
- [139] E.A. Betterton. *J. Atmos. Chem.*, **17**, 307 (1993).
- [140] D.W. Carlyle. *Inorg. Chem.*, **10**, 761 (1971).
- [141] A.N. Ermakov, A.P. Purmal. *Kinet. Catal.*, **43**, 249 (2002).
- [142] E.H. Cho. *Metall. Trans. B*, **17**, 745 (1986).
- [143] B. Podkrajšek, I. Grgić, J. Turšič. *Chemosphere*, **49**, 271 (2002).
- [144] M. Fischer, P. Warneck. *J. Phys. Chem.*, **100**, 15111 (1996).
- [145] C. Aubuchon. Ph.D. Thesis, John Hopkins University, Baltimore (1976).
- [146] S. Fuzzi. *Atmos. Environ.*, **12**, 1439 (1978).
- [147] T. Ibusuki, K. Takeuchi. *Atmos. Environ.*, **21**, 1555 (1987).
- [148] T. Ibusuki, H.M. Barnes. *Atmos. Environ.*, **18**, 145 (1984).
- [149] M. Iwai, H. Majima, Y. Awakura. *Metall. Trans. B*, **13B**, 311 (1982).
- [150] A. Huss, P.K. Lim, C.A. Eckert. *J. Phys. Chem.*, **86**, 4229 (1982).
- [151] C.R. Martins, C.A.C. Neto, J.J.F. Alves. *J. Braz. Chem. Soc.*, **10**, 453 (1999).
- [152] T.E. Eriksen. *J. Chem. Soc., Faraday Trans. 1*, **70**, 208 (1974).
- [153] W. Zhang, D. Muir, P. Singh. *Waste Processing and Recycling in Mineral and Metallurgical Industries. III. Proceedings of the 3rd International symposium on waste processing and recycling in mineral and metallurgical industries – Calgary, Alberta, 16–19 August*, p. 259 (1998).
- [154] H. Bassett, W.A. Parker. *J. Chem. Soc.*, 1540 (1951).
- [155] A.G. Clarke. *Atmos. Environ.*, **15**, 1591 (1981).
- [156] A.G. Clarke, M. Radojevic. *Atmos. Environ.*, **17**, 617 (1983).
- [157] A.G. Clarke, M. Radojevic. *Atmos. Environ.*, **18**, 2761 (1984).
- [158] F.J. Millero, S. Sotolongo, M. Izaguirre. *Geochim. Cosmochim. Acta*, **51**, 793 (1987).
- [159] F.J. Millero. *Mar. Chem.*, **28**, 1 (1989).
- [160] J. Zhou, W. Li, W. Xiao. *Chem. Eng. Sci.*, **55**, 5637 (2000).
- [161] E.R. Altwicker. In *Advances in Environmental Science and Engineering*, vol. 3, pp. 80–91, Gordon and Breach Science Publishers, New York (1980).
- [162] W. Pasiuk-Bronikowska, T. Bronikowski, M. Ulejczyk. *J. Phys. Chem. A*, **107**, 1742 (2003).
- [163] O.A. Travina, Ju.N. Kozlov, A.P. Purmal, I.J. Rod'ko. *J. Phys. Chem. (Rus)*, **73**, 1361 (1999).
- [164] J.Z. Zhang, F.J. Millero. *Geochim. Cosmochim. Acta*, **55**, 677 (1991).
- [165] H. Elias, U. Götz, K.J. Wannowius. *Atmos. Environ.*, **28**, 439 (1994).
- [166] W. Hoppel, L. Pasternack, P. Caffrey, G. Frick, J. Fitzgerald, D. Hegg, S. Gao, J. Ambrusko, T. Albrechtinski. *J. Geophys. Res. Atmos.*, **106**, 27575 (2001).
- [167] B.C. Faust, J. Hoigné. *Atmos. Environ.*, **24A**, 79 (1990).
- [168] M. Novič, I. Grgić, M. Poje, V. Hudnik. *Atmos. Environ.*, **30**, 4191 (1996).
- [169] N. Coichev, K.B. Reddy, R. van Eldik. *Atmos. Environ.*, **26A**, 2295 (1992).
- [170] M. Reda. *Water Sci. Technol.*, **20**, 45 (1988).
- [171] C. Brandt. Kinetic and mechanistic studies of the iron(III)-catalyzed autoxidation of sulphur(IV) oxides. Ph.D thesis, University of Witten/Herdecke, Germany (1994).
- [172] I. Grgić, V. Hudnik, M. Bizziak, J. Levec. *Atmos. Environ.*, **26A**, 571 (1992).
- [173] H.R. Pezza, R.L. Bonifácio, N. Coichev. *J. Chem. Res. Synop.*, **347**, 1520 (1999).
- [174] L.R. Martin, M.P. Easton, J.W. Foster, M.W. Hill. *Atmos. Environ.*, **23**, 563 (1989).
- [175] J.W. Munger, C. Tiller, M.R. Hoffmann. *Science*, **231**, 247 (1986).
- [176] W. Pasiuk-Bronikowska, T. Bronikowski, M. Ulejczyk. *J. Atmos. Chem.*, **44**, 97 (2003).
- [177] L.W. Richards, J.A. Anderson, D.L. Blumenthal, J.A. McDonald, G.L. Kok, A.L. Lazrus. *Atmos. Environ.*, **17**, 911 (1983).
- [178] K.J. Rudzinski. *J. Atmos. Chem.*, **48**, 191 (2004).
- [179] J. Ziajka, W. Pasiuk-Bronikowska. *Atmos. Environ.*, **39**, 1431 (2005).
- [180] I. Grgić, A. Dovžan, G. Berčič, V. Hudnik. *J. Atmos. Chem.*, **29**, 315 (1998).
- [181] A. Kotronarou, B. Sigg. *Environ. Sci. Tech.*, **27**, 2725 (1993).
- [182] A. Wolf, F. Deutsch, P. Hoffmann, H.M. Ortner. *J. Atmos. Chem.*, **37**, 125 (2000).
- [183] Y. Zuo, J. Zhan. *Atmos. Environ.*, **39**, 27 (2005).
- [184] A.W.F. Deutsch, P. Hoffmann, H.M. Ortner. *J. Atmos. Chem.*, **37**, 125 (2000).
- [185] G.V. Buxton, S. McGowan, G.A. Salmon, J.E. Williams, N.D. Wood. *Atmos. Environ.*, **30**, 2483 (1996).
- [186] A.C. Dash, K.C. Jena, A. Das. *Indian J. Chem.*, **38A**, 670 (1999).
- [187] M. Delleritter, R. van Eldik. *J. Chem. Soc., Dalton Trans.*, **6**, 1037 (1992).
- [188] M. Delleritter, R. van Eldik. *J. Chem. Soc., Dalton Trans.*, **6**, 1045 (1992).
- [189] D.W. Carlyle. *J. Am. Chem. Soc.*, **94**, 4525 (1972).
- [190] S. Tsunogai. *Geochem. J.*, **5**, 175 (1971).
- [191] J. Burgess. *Ions in Solution: Basic Principles in Chemical Interactions*, Ellis Horwood Limited Publishers, Chichester (1988).
- [192] D. Klug-Roth, J. Rabani. *J. Phys. Chem.*, **80**, 588 (1976).

- [193] L. Dogliotti, E. Hayon. *J. Phys. Chem.*, **71**, 2511 (1967).
- [194] H. Eibenberger, S. Steenken, P. O'Neill, D. Schulte-Frohlinde. *J. Phys. Chem.*, **82**, 749 (1978).
- [195] I. Kraljić. *Int. J. Radiat. Phys. Chem.*, **2**, 59 (1970).
- [196] M. Roder, L. Wojnárovits, G. Földiák, S.S. Emmi, G. Beggiato, M. D'Angelantonio. *Radiat. Phys. Chem.*, **54**, 475 (1999).
- [197] R.E. Huie, P. Neta. *J. Phys. Chem.*, **89**, 3918 (1985).
- [198] P. Neta, R.E. Huie. *J. Phys. Chem.*, **89**, 1783 (1985).
- [199] H. Herrmann, M. Exner, H.W. Jacobi, G. Raabe, A. Reese, R. Zellner. *Faraday Discuss.*, **100**, 129 (1995).
- [200] R.H. Schuler, G. Albarran. *Radiat. Phys. Chem.*, **64**, 189 (2002).
- [201] B.C. Gilbert, J.K. Stell. *J. Chem. Soc., Perkin Trans. 2*, 1281 (1990).
- [202] G.V. Buxton, J. Wang, G.A. Salmon. *Phys. Chem. Chem. Phys.*, **3**, 2618 (2001).
- [203] X.M. Pan, M.N. Schuchmann, C. von Sonntag. *J. Chem. Soc. Perkin Trans. 2*, 289 (1993).
- [204] J.W. Munger, D.J. Jacob, M.R. Hoffmann. *J. Atmos. Chem.*, **1**, 335 (1984).
- [205] G.L. Kok, S.N. Gitlin, A.L. Lazrus. *J. Geophys. Res.*, **88**, 5109 (1986).
- [206] M. Lindgren, A. Cedergren, J. Lindberg. *Anal. Chim. Acta*, **141**, 279 (1982).
- [207] S. Pitsch, R. Krishnamurthy, G. Arrhenius. *Helv. Chim. Acta*, **83**, 2398 (2000).
- [208] M.R. Hoffmann, S.D. Boyce. In *Trace Atmospheric Constituents: Properties, Transformations, and Fates, Advances in Environmental Science and Technology*, vol. 12, S.E. Schwartz (Ed.), John Wiley & Sons, New York (1983).
- [209] D.T.F. Kuo. A preliminary study of the redox behaviour of Fe(III)-S(IV)-O<sub>2(aq)</sub> system. MASC thesis, University of Toronto, Canada (2003).
- [210] H.L.J. Backström. *Z. Phys. Chem.*, **25B**, 122 (1934).
- [211] F. Haber. *Naturwissenschaften*, **19**, 450 (1931).
- [212] D.G. Karraker. *J. Phys. Chem.*, **67**, 871 (1963).
- [213] N. Coichev, R. van Eldik, R. Inorg. Chem., **30**, 2375 (1991).
- [214] J. Ziajka, F. Beer, P. Warneck. *Atmos. Environ.*, **28**, 2549 (1994).
- [215] A.N. Yermakov, I.K. Larin, A.A. Ugarov, A.P. Purmal. *Kinet. Catal.*, **44**, 476 (2003).
- [216] R.E. Connick, S. Lee, R. Adamic. *Inorg. Chem.*, **32**, 565 (1993).
- [217] E.A. Betteerton, M.R. Hoffmann. *J. Phys. Chem.*, **92**, 5962 (1988).
- [218] C. Walling. *Acc. Chem. Res.*, **8**, 125 (1975).
- [219] J. Freiberg. *Atmos. Environ.*, **9**, 661 (1975).
- [220] C.F. Kao. Thermodynamic and kinetic studies of the iron-sulphite system by electrochemical methods. Eng. ScD thesis, Columbia University, New York (1979).
- [221] V.K. Joshi, R. van Eldik, G.M. Harris. *Inorg. Chem.*, **25**, 2229 (1986).
- [222] A.R. Miksztal, J.S. Valentine. *Inorg. Chem.*, **23**, 3548 (1984).
- [223] T. Ozawa, T. Kwan. *Polyhedron*, **2**, 1019 (1983).
- [224] T. Ozawa, T. Kwan. *Polyhedron*, **4**, 1425 (1985).
- [225] T. Ozawa, T. Kwan. *Polyhedron*, **5**, 1531 (1986).
- [226] J.P. Collman, T.R. Halpert, K.S. Suslick. In *Metal Ion Activation of Dioxide*, T.G. Spiro (Ed.), pp. 1–72, Wiley-Interscience, New York (1980).
- [227] R.D. Jones, D.A. Summerville, F. Basolo. *Chem. Rev.*, **79**, 139 (1979).
- [228] C.C. Fu, B.J. McCoy, J.M. Smith. *AIChE J.*, **35**, 259 (1989).
- [229] V.M.H. Govindarao, K.V. Gopalakrishna. *Ind. Eng. Chem. Res.*, **34**, 2258 (1995).
- [230] H. Komiyama, J.M. Smith. *AIChE J.*, **21**, 664 (1975).
- [231] I. Kerezsi, G. Lente, I. Fábrián. *J. Chem. Soc., Dalton Trans.*, 955 (2006).
- [232] C.L. Clifton, N. Altstein, R.E. Huie. *Environ. Sci. Technol.*, **22**, 586 (1988).
- [233] D. Littlejohn, Y. Wang, S.G. Chang. *Environ. Sci. Technol.*, **27**, 2162 (1993).
- [234] S.B. Oblath, S.S. Markowitz, T. Novakov, S.G. Chang. *J. Phys. Chem.*, **86**, 4853 (1982).
- [235] V. Lepentiotis, F.F. Prinsloo, R. van Eldik, H. Gutberlet. *J. Chem. Soc., Dalton Trans.*, 2135 (1996).
- [236] V. Zang, R. van Eldik. *J. Chem. Soc., Dalton Trans.*, 111 (1993).
- [237] S.B. Oblath, S.S. Markowitz, T. Novakov, S.G. Chang. *J. Phys. Chem.*, **85**, 1071 (1981).
- [238] N. Coichev, R. van Eldik. *New J. Chem.*, **18**, 123 (1994).
- [239] A.R. Chughtai, M.E. Brooks, D.M. Smith. *Aerosol Sci. Technol.*, **19**, 121 (1993).
- [240] R. Bhargava, D.S.N. Prasad, A. Rani, P. Bhargava, U. Jain, K.S. Gupta. *Trans. Metal Chem.*, **17**, 238 (1992).
- [241] R. Bhargava, A. Rani, K.S. Gupta. *Indian J. Chem.*, **32A**, 713 (1993).
- [242] D.S.N. Prasad, A. Rani, P.V.S. Madnawat, R. Bhargava, K.S. Gupta. *J. Molec. Cata.*, **69**, 393 (1991).
- [243] R. Brodzinsky, S.G. Chang, S.S. Markowitz, T. Novakov. *J. Phys. Chem.*, **84**, 3354 (1980).
- [244] W. Stumm, B. Sulzberger. *Geochim. Cosmochim. Acta*, **56**, 3233 (1992).
- [245] T. Rigg, J. Weiss. *J. Chem. Phys.*, **20**, 1194 (1952).
- [246] J. Jortner, G. Stein. *J. Phys. Chem.*, **66**, 1258 (1962).
- [247] J. Jortner, G. Stein. *J. Phys. Chem.*, **66**, 1264 (1962).
- [248] L. Vincze, B. Kraut, A. Horváth, S. Papp. *Acta Chim. Hung.*, **112**, 183 (1983).
- [249] P.S. Braterman, A.G. Cairns-Smith, R.W. Sloper, T.G. Truscott, M. Craw. *J. Chem. Soc., Dalton Trans.*, 1441 (1984).
- [250] F.S. Dainton, W.D. Sisley. *Trans. Faraday Soc.*, **59**, 1377 (1963).
- [251] N. Brand, G. Mailhot, M. Bolte. *Environ. Sci. Technol.*, **32**, 2715 (1998).

- [252] G. Mailhot, A. Asif, M. Bolte. *Chemosphere*, **41**, 363 (2002).
- [253] J.M. Joseph, R. Varghese, C.T. Aravindakumar. *J. Photochem. Photobiol. A*, **146**, 67 (2001).
- [254] H.J. Benkelberg, P. Warneck. *J. Phys. Chem.*, **99**, 5214 (1995).
- [255] I.P. Pozdnyakov, Y.A. Sosedova, V.F. Plyusnin, E.M. Glebov, V.P. Grivin, D.Y. Vorobyev, N.M. Bazhin. *Int. J. Photoenergy*, **6**, 89 (2004).
- [256] Y. Zuo, J. Hoigné. *Atmos. Environ.*, **28**, 1231 (1994).
- [257] B.M. Voelker, F.M.M. Morel, B. Sulzberger. *Environ. Sci. Technol.*, **31**, 1004 (1997).
- [258] Y. Zuo, J. Hoigné. *Environ. Sci. Technol.*, **26**, 1014 (1992).
- [259] W.P. Kwan, B.M. Voelker. *Environ. Sci. Technol.*, **37**, 1150 (2003).
- [260] E. Hayon, J.J. McGarvey. *J. Phys. Chem.*, **71**, 1472 (1967).
- [261] G.V. Buxton, C.L. Greenstock, W.P. Helman, A.B. Ross. *J. Phys. Chem. Ref. Data*, **17**, 513 (1988).
- [262] G.G. Jayson, B.J. Parsons, A.J. Swallow. *J. Chem. Soc., Faraday Trans. 1*, **69**, 236 (1973).
- [263] H. Christensen, K. Sehested, T. Logager. *Radiat. Phys. Chem.*, **41**, 575 (1993).
- [264] T.J. Hardwick. *Can. J. Chem.*, **35**, 428 (1957).
- [265] J.D. Willey, R.F. Whitehead, R.J. Kieber, D.R. Hardison. *Environ. Sci. Technol.*, **39**, 2579 (2005).
- [266] C. Walling, G.M. El Taliawi. *J. Am. Chem. Soc.*, **95**, 844 (1973).
- [267] C. Walling, G.M. El Taliawi. *J. Am. Chem. Soc.*, **95**, 848 (1973).
- [268] G.V. Buxton, F. Djouider, D.A. Lynch, T.N. Malone. *J. Chem. Soc., Faraday Trans.*, **93**, 4265 (1997).
- [269] R.E. Huie, C.L. Clifton, N. Altstein. *Radiat. Phys. Chem.*, **33**, 361 (1989).
- [270] P. Neta, R.E. Huie. *J. Phys. Chem.*, **90**, 4644 (1986).
- [271] A.N. Yermakov, B.M. Zhitomirsky, G.A. Poskrebyshev, D.M. Sozurakov. *J. Phys. Chem.*, **97**, 10712 (1993).
- [272] A.N. Yermakov, B.M. Zhitomirsky, G.A. Poskrebyshev, S.I. Stoliarov. *J. Phys. Chem.*, **99**, 3120 (1995).
- [273] X. Sun, X. Shi, N.S. Dalai. *FEBS*, **303**, 213 (1992).
- [274] D.A. House. *Chem. Rev.*, **62**, 185 (1962).
- [275] G.V. Buxton, G.A. Salmon, J.E. Williams. *J. Atmos. Chem.*, **36**, 111 (2000).
- [276] O.P. Chawla, R.W. Fessenden. *J. Phys. Chem.*, **79**, 2693 (1975).
- [277] C. Liang, C.J. Bruell, M.C. Marley, K.L. Sperry. *Chemosphere*, **55**, 1213 (2004).
- [278] C. Liang, C.J. Bruell, M.C. Marley, K.L. Sperry. *Chemosphere*, **55**, 1225 (2004).
- [279] D.M. Stanbury. *Adv. Inorg. Chem.*, **33**, 69 (1989).
- [280] R.M. Felix-Navarro, S.W. Lin, A.B. Castro-Ceceña, H.A. Casco-Carrete. *J. Electrochem. Soc.*, **150**, D149 (2003).
- [281] F.A. Carey, R.J. Sundberg. *Advanced Organic Chemistry*, Kluwer Academic, New York (2000).
- [282] P. Brimblecombe, D.J. Spedding. *Atmos. Environ.*, **8**, 937 (1974).
- [283] F. Vidal, P. Ollero. *Environ. Sci. Technol.*, **35**, 2792 (2001).
- [284] L. Pettersson. In *Polyoxometalates: from Platonic Solids to Anti-Retroviral Activity*, A. Müller (Ed.), pp. 27–40, Kluwer Academic Publishers, Hague (1994).
- [285] L. Pettersson, B. Hedman, I. Andersson, N. Ingri. *Chemica Scripta*, **22**, 254 (1983).
- [286] C. Drexler, H. Elias, B. Fecher, K.J. Wannowius. *Fresenius J. Anal. Chem.*, **340**, 605 (1991).
- [287] D.C. Ramdon, D.A. Dixon, T.P. Dasgupta. *Inorg. React. Mech.*, **2**, 313 (2000).
- [288] B.R. van Dyke, D.A. Clopton, P. Saltman. *Inorg. Chim. Acta*, **242**, 57 (1996).
- [289] I.M. Kolthoff, I.K. Miller. *J. Am. Chem. Soc.*, **73**, 3055 (1951).
- [290] J.H. Mathews, L.J. Dewey. *J. Phys. Chem.*, **17**, 211 (1913).
- [291] J.A. Dean (Ed.). *Lange's Handbook of Chemistry*, McGraw-Hill, New York (1999).
- [292] D.R. Lide (Ed. Chief). *CRC Handbook of Chemistry and Physics 86<sup>th</sup> ed.*, CRC Press, Boca Raton (2006).
- [293] M.M. Benjamin. *Water Chemistry*, McGraw Hill, Boston (2002).
- [294] S.S. Gupta, Y.K. Gupta. *Inorg. Chem.*, **20**, 454 (1981).
- [295] W.B. Schaap, H.A. Laitinen, J.C. Bailar Jr. *J. Am. Chem. Soc.*, **76**, 5868 (1954).
- [296] B.H.J. Bielski, D.E. Cabelli, L. Ravindra, A.B. Ross. *J. Phys. Chem. Ref. Data*, **14**, 1041 (1985).
- [297] G.A. Poskrebyshev, P. Neta, R.E. Huie. *J. Phys. Chem.*, **106**, 11488 (2002).
- [298] D. Zehavi, J. Rabani. *J. Phys. Chem.*, **75**, 1738 (1971).
- [299] R.E. Büehler, J. Staehelin, J. Hoigne. *J. Phys. Chem.*, **88**, 2560 (1984).
- [300] A.E. Martell, R.M. Smith, R.J. Motekaitis. *Critically Selected Stability Constants of Metal Complexes Database*, U.S. Department of Commerce, National Institute of Standards and Technology (2004).
- [301] M. Uchimiya, A.T. Stone. *Geochim. Cosmochim. Acta*, **70**, 1388 (2006).
- [302] F.J. Millero. *Mar. Chem.*, **50**, 21 (1995).
- [303] D.W. King. *Environ. Sci. Technol.*, **32**, 2997 (1998).
- [304] G.V. Buxton, S. Croft, S. McGowan. In *Laboratory Study of the Aqueous Chemistry of Free Radicals, Transition Metals and Formation of Acidity in Clouds*, P. Warneck (Ed.), Final Report Contract No. STEP-0005-C(MB), April 1, 1990-March 31, 1992, pp. 61–74 (1992).
- [305] J.M. Santana-Casiano, M. González-Dávila, F.J. Millero. *Mar. Chem.*, **85**, 27 (2004).
- [306] P.L. Brown, R.N. Sylva. *J. Chem. Soc., Dalton Trans.*, 723 (1985).
- [307] G.H. Khoe, P.L. Brown, R.N. Sylva, R.G. Robbins. *J. Chem. Soc., Dalton Trans.*, 1901 (1986).
- [308] F.F. Prinsloo, C. Brandt, V. Lepentisiotis, J.J. Pienaar, R. van Eldik. *Inorg. Chem.*, **36**, 119 (1997).
- [309] G.G. Davis, M.W. Smith. *Can. J. Chem.*, **40**, 1836 (1962).
- [310] F.J. Miller, D.W. King, J. Lin, D.R. Kester. *Mar. Chem.*, **50**, 63 (1995).
- [311] J.M. Casas, G. Crisóstomo, L. Cifuentes. *Hydrometallurgy*, **80**, 254 (2005).
- [312] S. Lacroix. *Ann. Chim.*, **4**, 5 (1949).

- [313] R.F. Bauer, W.M. Smith. *Can. J. Chem.*, **43**, 2755 (1965).
- [314] P. Wardman. *J. Phys. Chem. Ref. Data*, **18**, 1637 (1989).
- [315] L. Ebersol. *Electron Transfer Reactions in Organic Chemistry*, Spring-Verlag, Berlin (1987).
- [316] U. Nickel, E. Haase, B. Thormann. *Z. Physik. Chem.*, **170**, 159 (1991).
- [317] W.M. Latimer. *Oxidation Potentials*, Prentice-Hall, Englewood Cliffs (1952).
- [318] S.G. Bratsch. *J. Phys. Chem. Ref. Data*, **18**, 1 (1989).
- [319] R. Sarala, S.B. Rabin, D.M. Stanbury. *Inorg. Chem.*, **30**, 3999 (1991).
- [320] L.C.T. Shoute, Z.B. Alfassi, P. Neta, R.E. Huie. *J. Phys. Chem.*, **95**, 3238 (1991).
- [321] D.D. Wagman, W.H. Evans, V.B. Parker, R.H. Schumm, I. Halow, S.M. Bailey, K.L. Churney, R.L. Nuttall. *J. Phys. Chem. Ref. Data*, **11**, Suppl. 2 (1982).
- [322] G.A. Poskrebyshev. *Zhurnal Fizicheskoi Khimii*, **71**, 1360 (1997).
- [323] J.S. Price, I.R. Tasker, E.H. Appelman, P.A.G. O'Hare. *J. Chem. Thermodyn.*, **18**, 923 (1986).
- [324] G.V. Buxton, T.N. Malone, G.A. Salmon. *J. Chem. Soc., Faraday Trans.*, **92**, 1287 (1996).
- [325] J. McElroy, S.J. Waywood. *J. Chem. Soc., Faraday Trans.*, **86**, 2557 (1990).
- [326] R.E. Huie, P. Neta. *Atmos. Environ.*, **21**, 5665 (1987).
- [327] R.E. Huie, P. Neta. *Atmos. Environ.*, **21**, 1743 (1987).
- [328] M.R. Hoffmann. *Atmos. Environ.*, **20**, 1145 (1986).
- [329] J.A. Lind, A.L. Lazrus, G.L. Kok. *J. Geophys. Res.*, **92**, 4171 (1987).
- [330] P.H. Wine, Y. Tang, R.P. Thorn, J.R. Wells. *J. Geophys. Res.*, **94**, 1085 (1989).
- [331] A. Reese, H. Herrmann, R. Zellner. In *Transport and Transformation of Pollutants in the Troposphere*, Vol. 1, P.M. Borrell, P. Borrell, T. Cvitaš, K. Kelly, W. Seiler (Eds.), Proceedings of EUROTRAC Symposium '96, pp. 377–381, Computational Mechanics Publications, Southampton (1997).
- [332] Y. Rudich, R.K. Talukdar, A.R. Ravishankara. *J. Geophys. Res. D*, **103**, 16133 (1998).
- [333] H. Takeuchi, M. Ando, N. Kizawa. *Ind. Eng. Chem., Process Des. Dev.*, **16**, 303 (1977).
- [334] H.W. Jacobi, H. Herrmann, R. Zellner. In *Air Pollution Research Report 57: Homogeneous and Heterogeneous Chemical Processes in the Troposphere*, Ph. Mirabel (Ed.), pp. 172–176, Office for Official Publications of the European Communities, Luxembourg (1996).
- [335] A.B. Ross, B.H.J. Bielski, G.V. Buxton, C.L. Greenstock, W.P. Helman, R.E. Huie, J. Grodkowski, P. Neta, W.G. Mallard. *NDRL-NIST Solution Kinetics Database, Version 3, NIST Standard Reference Database 40*, National Institute of Standards and Technology, Gaithersburg (1994).
- [336] R.E. Huie, L.C.T. Shoute, P. Neta. *Int. J. Chem. Kinet.*, **23**, 541 (1991).
- [337] P. Maruthamuthu, P. Neta. *J. Phys. Chem.*, **82**, 710 (1978).
- [338] H. Herrmann, A. Reese, R. Zellner. *J. Mol. Struct.*, **348**, 183 (1995).
- [339] Z.C. Bao, J.R. Barker. *J. Phys. Chem.*, **100**, 9780 (1996).
- [340] R.E. Huie, C.L. Clifton. *J. Phys. Chem.*, **94**, 8561 (1990).
- [341] H. Herrmann, H.W. Jacobi, A. Reese, R. Zellner. In *Transport and Transformation of Pollutants in the Troposphere*, Vol. 1, Proceedings of EUROTRAC Symposium '96, P.M. Borrell, T. Cvitaš, K. Kelly, W. Seiler (Eds.), pp. 407–411, Computational Mechanics Publications, Southampton (1997).
- [342] C.L. Clifton, R.E. Huie. *Int. J. Chem. Kinet.*, **21**, 677 (1989).
- [343] P. Warneck, P. Mirabel, G.A. Salmon, R. van Eldik, C. Winker, K.J. Wannowius, L.C. Zetzst. In *Heterogeneous and Liquid Phase Process*, P. Warneck Ed., Berlin: Springer, 1996, Part 2, 7–102.
- [344] T. Sadat-Shafai, J. Pucheault, C. Ferradini. *Radiat. Phys. Chem.*, **17**, 283 (1981).
- [345] D. Behar, R.W. Fessenden, J.P. Hornak. *Radiat. Phys. Chem.*, **20**, 267 (1982).
- [346] D.M. Bartels, R.G. Lawler. *J. Chem. Phys.*, **86**, 4843 (1987).
- [347] D. Behar, R.W. Fessenden. *J. Phys. Chem.*, **76**, 1706 (1972).
- [348] S.N. Pandis, J.H. Seinfeld. *J. Geophys. Res. D*, **94**, 1105 (1989).
- [349] A. van den Berg, F. Dentner, J. Lelieveld. *J. Geophys. Res. D*, **105**, 11671 (2000).
- [350] H. Christensen, K. Sehested. *Radiat. Phys. Chem.*, **18**, 723 (1981).
- [351] G.G. Jayson, B.J. Parsons, A.J. Swallow. *J. Chem. Soc., Faraday Trans. 1*, **68**, 2053 (1972).
- [352] Y.J. Lee, G.T. Rochelle. *Environ. Sci. Technol.*, **21**, 266 (1987).
- [353] E. Heckel, A. Henglein, G. Beck. *Ber. Bunsen-Ges. Phys. Chem.*, **70**, 149 (1966).
- [354] H. Herrmann, H.W. Jacobi, G. Raabe, A. Reese, R. Zellner. *Fresenius J. Anal. Chem.*, **355**, 343 (1996).
- [355] P. Warneck. In *Laboratory Study of the Aqueous Chemistry of Free Radicals, Transition Metals and Formation of Acidity in Clouds*, P. Warneck (Ed.), Final Report Contract No. STEP-0005-C(MB), April 1, 1990–March 31, 1992, pp. 1–10 (1992).
- [356] R. Woods, I.M. Kolthoff, E.J. Meehan. *J. Am. Chem. Soc.*, **85**, 2385 (1963).
- [357] H. Diebler, N. Sutin. *J. Phys. Chem.*, **68**, 174 (1964).
- [358] A.T. Thornton, G.S. Laurence. *J. Chem. Soc., Dalton Trans.*, 804 (1973).
- [359] T. Logager, J. Holcman, K. Sehested, T. Pedersen. *Inorg. Chem.*, **31**, 3523 (1992).
- [360] D.L. Sedlak, J. Hoigné. *J. Atmos. Environ.*, **27A**, 2173 (1993).
- [361] H.J. Benkelberg, A. Schäfer, P. Warneck. In *Air Pollution Research Report 33: Atmospheric Oxidation Processes*, K.H. Becker (Ed.), pp. 130–133, CEC, Brussels (1991).
- [362] R. Zellner, M. Exner, H. Herrmann. *J. Atmos. Chem.*, **10**, 411 (1990).
- [363] K. Sehested, J. Holcman, T.J. Hart. *J. Phys. Chem.*, **87**, 1951 (1983).
- [364] H. Christensen, K. Sehested, E. Bjergbakke. *Water Chem. Nucl. React. Syst.*, **5**, 141 (1989).
- [365] A.J. Elliot, G.V. Buxton. *J. Chem. Soc., Faraday Trans.*, **88**, 2465 (1992).
- [366] Y. Tang, R.P. Thorn, R.L. Mauldin III, P.H. Wine. *J. Photochem. Photobiol. A*, **44**, 243 (1988).



- [367] P. Maruthamuthu, P. Neta. *J. Phys. Chem.*, **81**, 937 (1977).  
 [368] H. Christensen, K. Sehested, H. Corfitzen. *J. Phys. Chem.*, **86**, 1588 (1982).  
 [369] H.S. Harned, B.B. Owen. *The Physical Chemistry of Electrolytic Solutions*, Reinhold, New York (1958).  
 [370] T.E. Graedel, C.J. Weschler. *Rev. Geophys. Space Phys.*, **19**, 505 (1981).  
 [371] C. Marsh, J.O. Edwards. *Prog. React. Kinet.*, **15**, 35 (1989).  
 [372] P. Hemmes, L.D. Rich, D.L. Cole, E.N. Eyring. *J. Phys. Chem.*, **75**, 929 (1971).  
 [373] S. Beilke, G. Gravenhorst. *Atmos. Environ.*, **12**, 231 (1978).  
 [374] R.H. Betts, R.H. Voss. *Can. J. Chem.*, **48**, 2035 (1970).  
 [375] O. Redlich. *Chem. Rev.*, **39**, 333 (1946).  
 [376] A.R.W. Marsh, W.J. McElroy. *Atmos. Environ.*, **19**, 1075 (1985).  
 [377] K.S. Gupta, I.U. Jain, A. Singh, R.K. Mehta, S.V. Manoj, D.S.N. Prasad, A. Sharma, P. Parashar, S.P. Bansal. *J. Indian Chem. Soc.*, **81**, 1083 (2004).  
 [378] W. Stumm, G.F. Lee. *Ind. Eng. Chem.*, **53**, 143 (1961).  
 [379] T.J. Larson, N.R. Horike, H. Harrison. *Atmos. Environ.*, **12**, 1597 (1978).  
 [380] F.G. Neytzell-de Wilde, L. Traverner. In *2<sup>nd</sup> U.N. International Conference on Peaceful Uses for Atomic Energy Proceedings*, vol. 3, pp. 303–317 (1958).  
 [381] G.V. Buxton, G.A. Salmon, N.D. Wood. In *Proceedings of the Fifth European Symposium: Physico-Chemical Behaviour of Atmospheric Pollutants*, G. Restelli, G. Angeletti (Eds.), pp. 245–250, Kluwer, Dordrecht (1990).  
 [382] S.W. Benson. *Chem. Rev.*, **78**, 23 (1978).

## Appendix A: Aqueous solubilities and Henry's Law constants for selected gases

### A1 Aqueous solubilities of selected gases

$$[\text{O}_2]_{\text{aq}} = \exp \left\{ \frac{1.045 \times 10^6}{T^2} - \frac{5.55 \times 10^3}{T} + 1.88 \times 10^{-1} \right\} \quad [T = 0\text{--}100^\circ\text{C}] \quad [291]$$

$$[\text{SO}_2]_{\text{aq}} = \exp \left\{ \frac{-1.265 \times 10^6}{T^2} + \frac{1.18 \times 10^3}{T} - 2.49 \times 10^{-1} \right\} \quad [T = 0\text{--}40^\circ\text{C}] \quad [291]$$

Note: T in °K,  $[\text{O}_2]_{\text{aq}}$  in M  $\text{O}_{2\text{aq}}/1 \text{ atm O}_2$ ,  $[\text{SO}_2]_{\text{aq}}$  in M  $\text{SO}_{2\text{aq}}/1 \text{ atm SO}_2 + \text{H}_2\text{O}$

$$X(\text{O}_{2\text{aq}}) = \exp \left\{ -66.7 + \frac{87.5}{T^*} + 24.5 \ln T^* \right\} \quad [T = 0\text{--}75^\circ\text{C}] \quad [292]$$

$$X(\text{SO}_{2\text{aq}}) = \exp \left\{ -25.3 + \frac{45.8}{T^*} + 5.69 \ln T^* \right\} \quad [T = 5\text{--}55^\circ\text{C}] \quad [292]$$

$$X(\text{NO}_{\text{aq}}) = \exp \left\{ -62.8 + \frac{82.3}{T^*} + 22.8 \ln T^* \right\} \quad [T = 0\text{--}85^\circ\text{C}] \quad [292]$$

$$X(\text{N}_2\text{O}_{\text{aq}}) = \exp \left\{ -60.7 + \frac{88.8}{T^*} + 21.3 \ln T^* \right\} \quad [T = 0\text{--}40^\circ\text{C}] \quad [292]$$

Note: T\* in T/100 (°K),  $X(i_{\text{aq}})$  = mole fraction  $i_{\text{aq}}/1$ , atm  $i_{\text{g}}$

### A2 Henry's Law constant, $K_{\text{HL}}$ , for selected gases at 20–25 °C\*

| Gas                           | $K_{\text{HL}}$ (bar/M) |
|-------------------------------|-------------------------|
| N <sub>2</sub>                | 1560 <sup>a</sup>       |
| O <sub>2</sub>                | 790 <sup>a</sup>        |
| CO <sub>2</sub>               | 28.8 <sup>a</sup>       |
| H <sub>2</sub> S              | 9.8 <sup>a</sup>        |
| SO <sub>2</sub>               | 0.81 <sup>a</sup>       |
| NH <sub>3</sub>               | 0.017 <sup>a</sup>      |
| NO <sub>2</sub>               | 100 <sup>b</sup>        |
| H <sub>2</sub> O <sub>2</sub> | $9.5 \times 10^{-6b}$   |
| O <sub>3</sub>                | 106 <sup>c</sup>        |

\* $K_{\text{HL},i} = P_i/i_i$ .

<sup>a</sup>ref. [293]; <sup>b</sup>ref. [233]; <sup>c</sup>ref. [265].

**Appendix B: Thermodynamic properties related to aqueous Fe-S(IV)-O<sub>2</sub> system****B1 Acid dissociation constants for oxysulphur acids at 25 °C and I = 0 M**

| No.          | Dissociation reactions   | $pK_a = -\log K_a$ | $T; I(M)$      | Reference  |
|--------------|--|--------------------|----------------|------------|
| <b>B1.1</b>  | *H <sub>2</sub> SO <sub>3</sub> → HSO <sub>3</sub> <sup>-</sup> + H <sup>+</sup>   | 1.85               | 25 °C          | [292]      |
|              |  | 1.89               |                | [291]      |
|              |  | 1.91               |                | [136]      |
| <b>B1.2</b>  | HSO <sub>3</sub> <sup>-</sup> → SO <sub>3</sub> <sup>2-</sup> + H <sup>+</sup>   | 7.18               |                | [136]      |
|              |  | 7.2                | 25 °C          | [292]      |
|              |  | 7.21               |                | [291]      |
| <b>B1.3</b>  | HSO <sub>4</sub> <sup>-</sup> → SO <sub>4</sub> <sup>2-</sup> + H <sup>+</sup>   | 1.92               | 25 °C          | [96]       |
|              |  | 1.99               | 25 °C          | [292, 291] |
| <b>B1.4</b>  | H <sub>2</sub> SO <sub>5</sub> → HSO <sub>5</sub> <sup>-</sup> + H <sup>+</sup>  | 1.0                | ~25 °C; I ~ 0  | [57]       |
|              |  | 1.0                | 25 °C          | [291]      |
| <b>B1.5</b>  | HSO <sub>5</sub> <sup>-</sup> → SO <sub>5</sub> <sup>2-</sup> + H <sup>+</sup>   | 9.3, 9.4           | ~25 °C; I ~ 0  | [57, 38]   |
|              |  | 9.86               |                | [291]      |
| <b>B1.6</b>  | H <sub>2</sub> S <sub>2</sub> O <sub>3</sub> → HS <sub>2</sub> O <sub>3</sub> <sup>-</sup> + H <sup>+</sup>                        | 0.6                | 25 °C          | [291]      |
| <b>B1.7</b>  | HS <sub>2</sub> O <sub>3</sub> <sup>-</sup> → S <sub>2</sub> O <sub>3</sub> <sup>2-</sup> + H <sup>+</sup>                         | 1.74               | 25 °C          | [291]      |
| <b>B1.8</b>  | H <sub>2</sub> S <sub>2</sub> O <sub>4</sub> → HS <sub>2</sub> O <sub>4</sub> <sup>-</sup> + H <sup>+</sup>                        | 0.35               | 25 °C          | [291]      |
| <b>B1.9</b>  | HS <sub>2</sub> O <sub>4</sub> <sup>-</sup> → S <sub>2</sub> O <sub>4</sub> <sup>2-</sup> + H <sup>+</sup>                         | 2.45               | 25 °C          | [291]      |
| <b>B1.10</b> | H <sub>2</sub> S <sub>2</sub> O <sub>6</sub> → HS <sub>2</sub> O <sub>6</sub> <sup>-</sup> + H <sup>+</sup>                        | -3.4               | 25 °C          | [291]      |
| <b>B1.11</b> | HS <sub>2</sub> O <sub>6</sub> <sup>-</sup> → S <sub>2</sub> O <sub>6</sub> <sup>2-</sup> + H <sup>+</sup>                         | -0.2               | 25 °C          | [291]      |
| <b>B1.12</b> | H <sub>2</sub> S <sub>2</sub> O <sub>7</sub> → HS <sub>2</sub> O <sub>7</sub> <sup>-</sup> + H <sup>+</sup>                        | -12**              | 25 °C          | [291]      |
| <b>B1.13</b> | HS <sub>2</sub> O <sub>7</sub> <sup>-</sup> → S <sub>2</sub> O <sub>7</sub> <sup>2-</sup> + H <sup>+</sup>                         | -8**               | 25 °C          | [291]      |
| <b>B1.14</b> | HS <sub>2</sub> O <sub>8</sub> <sup>-</sup> → S <sub>2</sub> O <sub>8</sub> <sup>2-</sup> + H <sup>+</sup>                         | >1.3               | 30–40 °C       | [294]      |
| <b>B1.15</b> | NH <sub>2</sub> SO <sub>3</sub> H → NH <sub>2</sub> SO <sub>3</sub> <sup>-</sup> + H <sup>+</sup>                                  | 1.05               | ~25 °C         | [292]      |
| <b>B1.16</b> | HON(SO <sub>3</sub> ) <sub>2</sub> <sup>2-</sup> → ON(SO <sub>3</sub> ) <sub>3</sub> <sup>3-</sup> + H <sup>+</sup>                | 11.85              | 25 °C; I = 1.6 | [291]      |
| <b>B1.17</b> | H <sub>3</sub> NOSO <sub>3</sub> → H <sub>2</sub> NOSO <sub>3</sub> <sup>-</sup> + H <sup>+</sup>                                  | 1.48               | 25 °C; I = 1   | [291]      |
| <b>B1.18</b> | Fe(SO <sub>3</sub> ) <sub>3</sub> H <sub>2</sub> <sup>-</sup> → Fe(SO <sub>3</sub> ) <sub>3</sub> H <sup>2-</sup> + H <sup>+</sup> | 1.4                | 25 °C; I = 0.1 | [73]       |
| <b>B1.19</b> | Fe(SO <sub>3</sub> ) <sub>3</sub> H <sup>2-</sup> → Fe(SO <sub>3</sub> ) <sub>3</sub> <sup>3-</sup> + H <sup>+</sup>               | 2.8                | 25 °C; I = 0.1 | [73]       |

\*SO<sub>2</sub> + H<sub>2</sub>O → HSO<sub>3</sub><sup>-</sup> + H<sup>+</sup>.

\*\*Theoretical predicted values.

**B2 Acid dissociation constants for other acids at 25 °C and I = 0 M\***

| No.         | Dissociation reactions  | $pK_a = -\log K_a$ | $T; I(M)$ | Reference |
|-------------|---|--------------------|-----------|-----------|
| <b>B2.1</b> | HAc → Ac <sup>-</sup> + H <sup>+</sup>                                | 4.76               |           | [291]     |
| <b>B2.2</b> | H <sub>3</sub> Cit → H <sub>2</sub> Cit <sup>-</sup> + H <sup>+</sup> | 3.1                |           | [79]      |
| <b>B2.3</b> | H <sub>2</sub> Cit <sup>-</sup> → HCit <sup>2-</sup> + H <sup>+</sup> | 4.8                |           | [79]      |
| <b>B2.4</b> | HCit <sup>2-</sup> → Cit <sup>3-</sup> + H <sup>+</sup>               | 6.4                |           | [79]      |
| <b>B2.7</b> | HForm → Form <sup>-</sup> + H <sup>+</sup>                            | 3.75               |           | [291]     |
| <b>B2.8</b> | HGly → Gly <sup>-</sup> + H <sup>+</sup>                              | 3.83               |           | [79, 291] |

(continued)

| No.          | Dissociation reactions                     | $pK_a = -\log K_a$ | $T; I (M)$ | Reference |
|--------------|--|--------------------|------------|-----------|
| <b>B2.9</b>  | $H_2Mal \rightarrow HMal^- + H^+$          | 2.83, 2.85         |            | [79, 291] |
| <b>B2.10</b> | $HMal^- \rightarrow Mal^{2-} + H^+$        | 5.70               |            | [79, 291] |
| <b>B2.11</b> | $H_2Oxa \rightarrow HOxa^- + H^+$          | 1.19               |            | [295]     |
|              |  | 1.27               |            | [291]     |
| <b>B2.12</b> | $HOxa^- \rightarrow Oxa^{2-} + H^+$        | 4.21               |            | [295]     |
|              |  | 4.27               |            | [291]     |
| <b>B2.13</b> | $HO_2^* \rightarrow O_2^{*-} + H^+$        | 4.8                |            | [296]     |
| <b>B2.14</b> | $\bullet HO \rightarrow \bullet O^- + H^+$ | 11.5               |            | [297]     |
|              |  | 11.9               |            | [298]     |
| <b>B2.15</b> | $HO_3^* \rightarrow O_3^{*-} + H^+$        | 8.2                |            | [299]     |
| <b>B2.16</b> | $H_2O_2 \rightarrow HO_2^- + H^+$          | 11.7               |            | [261]     |

\*Ace = acetate ( $CH_3COO^-$ ), Cit = citrate ( $C_3H_5O(COO)_3^{3-}$ ), Form = formate ( $HCOO^-$ ), Gly = glycolate ( $CH_2OHCOO^-$ ), Mal = malonate ( $CH_2(COO)_2^{2-}$ ), Oxa = oxalate ( $C_2O_4^{2-}$ ).

### B3 Complex formation constants for Fe(II) and inorganic anions at 25 °C, I = 0 M

| No.          | Complexes              | $\log \beta^a$ | Condition            | Reference   |
|--------------|------------------------|----------------|----------------------|-------------|
| <b>B3.1</b>  | $Fe^{II}OH^+$          | 4.5            |                      | [79]        |
|              |                        | 4.6            | I = 0 M <sup>b</sup> | [300, 301]  |
|              |                        | 5.6            | 20–25 °C, I ~ 0 M    | [291]       |
| <b>B3.2</b>  | $Fe^{II}(OH)_2$        | 7.4            |                      | [79]        |
|              |                        | 7.5            | I = 0 M <sup>b</sup> | [300, 301]  |
|              |                        | 9.8            | 20–25 °C, I ~ 0 M    | [291]       |
| <b>B3.3</b>  | $Fe^{II}(OH)_3^-$      | 9.7            | 20–25 °C, I ~ 0 M    | [291]       |
|              |                        | 11.0           |                      | [79]        |
|              |                        | 13.5           | I = 0 M <sup>b</sup> | [300] [301] |
| <b>B3.4</b>  | $Fe^{II}(OH)_4^{2-}$   | 8.6            | 20–25 °C, I ~ 0 M    | [291]       |
|              |                        | 10.0           | I = 0 M <sup>b</sup> | [300] [301] |
| <b>B3.5</b>  | $Fe^{II}CO_3$          | 5.5            |                      | [302]       |
|              |                        | 5.7            |                      | [303]       |
|              |                        | 7.2            |                      | [302]       |
| <b>B3.6</b>  | $Fe^{II}(CO_3)_2^{2-}$ | 7.5            |                      | [303]       |
|              |                        | 11.8           |                      | [303]       |
|              |                        | 10.0           |                      | [303]       |
| <b>B3.7</b>  | $Fe^{II}HCO_3^+$       | 0.3            |                      | [303]       |
| <b>B3.8</b>  | $Fe^{II}(CO_3)(OH)^-$  | 0.36           | 20–25 °C, I ~ 0 M    | [291]       |
| <b>B3.9</b>  | $Fe^{II}Cl^+$          | 35.4           |                      | [79]        |
| <b>B3.10</b> | $Fe^{II}(CN)_6^{4-}$   | 1.4            |                      | [79]        |
| <b>B3.11</b> | $Fe^{II}F^+$           | 16.0           |                      | [79]        |
| <b>B3.12</b> | $Fe^{II}HPO_4$         | 22.3           |                      | [79]        |
| <b>B3.13</b> | $Fe^{II}H_2PO_4^+$     | 8.4            |                      | [114]       |
| <b>B3.14</b> | $Fe^{II}SO_3$          | 8.4            |                      | [114]       |
|              |                        | 9.9            |                      | [304]       |
|              |                        | 2.2            |                      | [79]        |
| <b>B3.15</b> | $Fe^{II}SO_4$          | 2.2            |                      | [79]        |
|              |                        | 2.25           |                      | [81]        |
|              |                        | 2.4            |                      | [303]       |

<sup>a</sup>Complex formation constant (or stability constant)  $\beta = [M_V(H)_W(OH)_X L_Y^{Z\pm}] / \{[M^{a+}]^V [L^b]^{Y'} [OH^-]^{X'} [H^+]^{W'}\}$ , all concentrations in the unit of M.

<sup>b</sup>Corrected to 0 M ionic strength by Uchimiya *et al.* 2006 [301]. For temperature, please refer to Martell *et al.* 2004 [300].

**B4 Complex formation constants for Fe(II) and organic anions at 25 °C, I = 0 M\***

| No.          | Complexes   | log β <sup>a</sup> | Condition            | Reference   |
|--------------|---|--------------------|----------------------|-------------|
| <b>B4.1</b>  | Fe <sup>II</sup> Ace <sup>+</sup>                     | 1.4                |                      | [79]        |
|              |   | 3.2                | I = 0.1 M            | [291]       |
| <b>B4.2</b>  | Fe <sup>II</sup> (Ace) <sub>2</sub>                   | 6.1                | I = 0.1 M            | [291]       |
| <b>B4.3</b>  | Fe <sup>II</sup> (Ace) <sub>3</sub> <sup>-</sup>      | 8.3                | I = 0.1 M            | [291]       |
| <b>B4.4</b>  | Fe <sup>II</sup> Cit <sup>-</sup>                     | 5.7                |                      | [79]        |
| <b>B4.5</b>  | Fe <sup>II</sup> HCit                                 | 9.9                |                      | [79]        |
| <b>B4.6</b>  | Fe <sup>II</sup> EDA <sup>2+</sup>                    | 4.3                |                      | [79, 291]   |
| <b>B4.7</b>  | Fe <sup>II</sup> (EDA) <sub>2</sub> <sup>2+</sup>     | 7.7                |                      | [79, 291]   |
| <b>B4.8</b>  | Fe <sup>II</sup> (EDA) <sub>3</sub> <sup>2+</sup>     | 9.7                |                      | [79, 291]   |
| <b>B4.9</b>  | Fe <sup>II</sup> EDTA <sup>2-</sup>                   | 14.3               | 20–25 °C, I ~ 0 M    | [291]       |
|              |   | 16.1               |                      | [79]        |
| <b>B4.10</b> | Fe <sup>II</sup> HEDTA <sup>-</sup>                   | 19.3               |                      | [79]        |
| <b>B4.11</b> | Fe <sup>II</sup> OHEDTA <sup>3-</sup>                 | 20.4               |                      | [79]        |
| <b>B4.12</b> | Fe <sup>II</sup> (OH) <sub>2</sub> EDTA <sup>4-</sup> | 23.7               |                      | [79]        |
| <b>B4.13</b> | Fe <sup>II</sup> Glu                                  | 4.6                |                      | [79]        |
| <b>B4.14</b> | Fe <sup>II</sup> Gly <sup>+</sup>                     | 1.9                |                      | [79]        |
| <b>B4.15</b> | Fe <sup>II</sup> Mal                                  | 3.0                | I = 0 M <sup>b</sup> | [300, 301]  |
| <b>B4.16</b> | Fe <sup>II</sup> (Mal) <sub>2</sub> <sup>2-</sup>     | 4.0                | I = 0 M <sup>b</sup> | [300, 301]  |
| <b>B4.17</b> | Fe <sup>II</sup> Oxa                                  | 2.9                | 20–25 °C, I ~ 0 M    | [291]       |
|              |   | 3.9                | I = 0 M <sup>b</sup> | [300] [301] |
| <b>B4.18</b> | Fe <sup>II</sup> (Oxa) <sub>2</sub> <sup>2-</sup>     | 4.5                | 20–25 °C, I ~ 0 M    | [291]       |
|              |   | 5.9                | I = 0 M <sup>b</sup> | [300, 301]  |
| <b>B4.19</b> | Fe <sup>II</sup> (Oxa) <sub>3</sub> <sup>4-</sup>     | 5.2                | 20–25 °C, I ~ 0 M    | [291]       |
|              |   | 5.2                | I = 0 M <sup>b</sup> | [300, 301]  |
| <b>B4.20</b> | Fe <sup>II</sup> Phtha                                | 2.7                | I = 0.7 M            | [305]       |
| <b>B4.21</b> | Fe <sup>II</sup> Sal                                  | 6.5                | I = 0.7 M            | [305]       |
|              |   | 7.4                |                      | [79]        |
| <b>B4.22</b> | Fe <sup>II</sup> (Sal) <sub>2</sub> <sup>2-</sup>     | 11.1               | I = 0.7 M            | [305]       |
|              |   | 12.1               |                      | [79]        |

\*Ace = acetate (CH<sub>3</sub>COO<sup>-</sup>), Cit = citrate (C<sub>3</sub>H<sub>5</sub>O(COO)<sub>3</sub><sup>3-</sup>), EDA = ethylene diamine (H<sub>2</sub>NC<sub>2</sub>H<sub>4</sub>NH<sub>2</sub>), EDTA = ethylenediaminetetraacetate (C<sub>6</sub>H<sub>12</sub>N<sub>2</sub>(COO<sup>-</sup>)<sub>4</sub><sup>4-</sup>), Glu = glutamate (<sup>-</sup>OOC(NH<sub>2</sub>)C<sub>3</sub>H<sub>5</sub>COO<sup>-</sup>), Gly = glycolate (CH<sub>2</sub>OHCOO<sup>-</sup>), Lac = lactate (CH<sub>3</sub>CH(OH)COO<sup>-</sup>), Mal = malonate (CH<sub>2</sub>(COO)<sub>2</sub><sup>2-</sup>), Oxa = oxalate (C<sub>2</sub>O<sub>4</sub><sup>2-</sup>), Phtha = o-phthalate (C<sub>6</sub>H<sub>4</sub>(COO<sup>-</sup>)<sub>2</sub>), Sal = salicylate (C<sub>6</sub>H<sub>4</sub>(Od)COO<sup>-</sup>).

<sup>a</sup>Complex formation constant β = [M<sub>v</sub>(H)<sub>w</sub>(OH)<sub>x</sub>L<sub>v</sub><sup>z±</sup>]/[M<sup>a+</sup>]<sup>v</sup>[L<sup>b-</sup>]<sup>w</sup>[OH<sup>-</sup>]<sup>x</sup>[H<sup>+</sup>]<sup>w</sup>, all concentrations in the unit of M.

<sup>b</sup>Corrected to 0 M ionic strength by Uchimiya *et al.* 2006 [301]. For temperature, please refer to Martell *et al.* 2004 [300].



$$K = 8.5 \times 10^2 \text{ M}^{-1}$$

Betterton, 1993.

**B5 Complex formation constants for Fe(III) and inorganic anions at 25 °C, I = 0 M**

| No.          | Complexes                                    | log $\beta^a$     | Condition            | Reference                |
|--------------|--|-------------------|----------------------|--------------------------|
| <b>B5.1</b>  | $\text{Fe}^{\text{III}}\text{OH}^{2+}$       | 11.3              | I = 1.0 M            | [45]                     |
|              |  | 11.8 <sup>b</sup> |                      | [306]                    |
|              |  | 11.8 <sup>b</sup> | I = 0.1 M            | [43]                     |
|              |  | 11.8              | I = 0 M <sup>b</sup> | [300, 301]               |
|              |  | 11.8 <sup>b</sup> |                      | [302]                    |
|              |  | 11.9              | 20–25 °C, I ~ 0 M    | [291]                    |
| <b>B5.2</b>  | $\text{Fe}^{\text{III}}(\text{OH})_2^+$      | 21.2              | 20–25 °C, I ~ 0 M    | [291]                    |
|              |  | 21.7              | I = 1.0 M            | [307]                    |
|              |  | 22.3 <sup>b</sup> | I = 0.1 M            | [43]                     |
|              |  | 22.3 <sup>b</sup> |                      | [306]                    |
|              |  | 22.5              |                      | [302]                    |
| <b>B5.3</b>  | $\text{Fe}^{\text{III}}(\text{OH})_3$        | 23.4              | I = 0 M <sup>b</sup> | [300, 301]               |
|              |  | 28.4              | I = 0 M <sup>b</sup> | [300, 301]               |
|              |  | 29.7              | 20–25 °C, I ~ 0 M    | [291]                    |
| <b>B5.4</b>  | $\text{Fe}^{\text{III}}(\text{OH})_4^-$      | 30.2              |                      | [302]                    |
|              |  | 34.4              |                      | [300, 301],<br>[302, 79] |
|              |  |                   |                      |                          |
| <b>B5.5</b>  | $\text{Fe}_2^{\text{III}}(\text{OH})_2^{4+}$ | 25.0              |                      | [79]                     |
|              |  | 25.1              | I = 0 M <sup>b</sup> | [300, 301]               |
|              |  | 25.2 <sup>b</sup> | I = 1 M              | [138]                    |
| <b>B5.6</b>  | $\text{Fe}_3^{\text{III}}(\text{OH})_4^{5+}$ | 48.4              | I = 1.0 M            | [307]                    |
|              |  | 49                | I = 1.0 M            | [307]                    |
|              |  | 49.7 <sup>b</sup> | I = 0 M <sup>b</sup> | [301]                    |
| <b>B5.7</b>  | $\text{Fe}^{\text{III}}\text{Br}^{2+}$       | 0.6               |                      | [79]                     |
| <b>B5.8</b>  | $\text{Fe}^{\text{III}}\text{Cl}^{2+}$       | 1.28              |                      | [302]                    |
|              |  | 1.3               |                      | [302]                    |
|              |  | 1.48              | 20–25 °C, I ~ 0 M    | [291]                    |
|              |  | 1.5               |                      | [79]                     |
| <b>B5.9</b>  | $\text{Fe}^{\text{III}}\text{Cl}_2^+$        | 1.16              |                      | [302]                    |
|              |  | 1.5               | 20–25 °C, I ~ 0 M    | [291]                    |
|              |  | 2.1               |                      | [79]                     |
| <b>B5.10</b> | $\text{Fe}^{\text{III}}\text{Cl}_3$          | 2.0               | 20–25 °C, I ~ 0 M    | [291]                    |
| <b>B5.11</b> | $\text{Fe}^{\text{III}}(\text{CN})_6^{3-}$   | 43.6              |                      | [79]                     |
| <b>B5.12</b> | $\text{Fe}^{\text{III}}\text{F}^{2+}$        | 5.3               | 20–25 °C, I ~ 0 M    | [291]                    |
|              |  | 6.0               |                      | [79]                     |
| <b>B5.13</b> | $\text{Fe}^{\text{III}}\text{F}_2^+$         | 9.3               | 20–25 °C, I ~ 0 M    | [291]                    |
|              |  | 10.6              |                      | [79]                     |
| <b>B5.14</b> | $\text{Fe}^{\text{III}}\text{F}_3$           | 12.1              | 20–25 °C, I ~ 0 M    | [291]                    |
|              |  | 13.7              |                      | [79]                     |
| <b>B5.15</b> | $\text{Fe}^{\text{III}}\text{HPO}_4^+$       | 22.5              |                      | [79]                     |

(continued)

| No.          | Complexes  | log $\beta^a$ | Condition         | Reference  |
|--------------|--|---------------|-------------------|------------|
| <b>B5.16</b> | Fe <sup>III</sup> H <sub>2</sub> PO <sub>4</sub> <sup>2+</sup>                 | 23.9          |                   | [79]       |
| <b>B5.17</b> | Fe <sup>III</sup> HSiO <sub>3</sub> <sup>+</sup>                               | 22.7          |                   | [79]       |
| <b>B5.18</b> | Fe <sup>III</sup> SO <sub>3</sub> <sup>+</sup>                                 | 6.6           | I = 0.4 M, pH ~ 2 | [136]      |
|              |  | 6.8           |                   | [139]      |
|              |  | 7.2           | I = 1.0 M         | [220]      |
|              |  | 7.8           | I = 0.1 M         | [308]      |
| <b>B5.19</b> | Fe <sup>III</sup> (SO <sub>3</sub> ) <sub>2</sub> <sup>-</sup>                 | 16.5          | I = 0.1 M, pH 1-3 | [43]       |
|              |  | 17.6          | I = 0.1 M         | [308]      |
| <b>B5.20</b> | Fe <sup>III</sup> (SO <sub>3</sub> ) <sub>3</sub> <sup>3-</sup>                | 27            | I = 0.1 M         | [308]      |
| <b>B5.21</b> | Fe <sup>III</sup> (HSO <sub>3</sub> ) <sub>2</sub> <sup>2+</sup>               | 8.9           |                   | [139]      |
|              |  | 9.1           |                   | [26]       |
| <b>B5.22</b> | Fe <sup>III</sup> OH(SO <sub>3</sub> )   | 19.1          |                   | [26]       |
|              |  | 19.1-19.7     | I = 0.4 M, pH ~ 2 | [136]      |
|              |  | 21.7          | I = 0.1 M, pH 1-3 | [43]       |
| <b>B5.23</b> | Fe <sup>III</sup> OH(HSO <sub>3</sub> ) <sup>+</sup>                           | 21.8          |                   | [26, 214]  |
|              |  | 21.9          |                   | [139]      |
| <b>B5.24</b> | Fe <sub>2</sub> <sup>III</sup> OH(SO <sub>3</sub> ) <sub>3</sub> <sup>3+</sup> | 36.1          | I = 1.0 M         | [45]       |
| <b>B5.25</b> | Fe <sup>III</sup> S <sub>2</sub> O <sub>3</sub> <sup>-</sup>                   | 2.1           | 20-25 °C, I ~ 0 M | [291]      |
|              |  | 3.3           |                   | [79]       |
| <b>B5.26</b> | Fe <sup>III</sup> S <sub>2</sub> O <sub>3</sub> <sup>-</sup>                   | 2.1           | 20-25 °C, I ~ 0 M | [291]      |
|              |  | 3.3           |                   | [79]       |
| <b>B5.27</b> | Fe <sup>III</sup> SO <sub>4</sub> <sup>+</sup>                                 | 2.3           | I = 0.5 M         | [309]      |
|              |  | 2.4           |                   | [141]      |
|              |  | 4.0           |                   | [79, 81]   |
|              |  | 4.3           |                   | [310, 302] |
| <b>B5.28</b> | Fe <sup>III</sup> (SO <sub>4</sub> ) <sub>2</sub> <sup>-</sup>                 | 5.4           |                   | [79, 81]   |
|              |  | 6.1           |                   | [302]      |
| <b>B5.29</b> | Fe <sup>III</sup> H(SO <sub>4</sub> ) <sub>2</sub>                             | 8.1           |                   | [311]      |

<sup>a</sup>Complex formation constant (or stability constant)  $\beta = [M_V(H)_W(OH)_X L_Y^{Z\pm}] / [M^{a+}]^V [L^{b-}]^Y [OH^-]^X [H^+]^W$ , all concentrations in the unit of M.

<sup>b</sup>Corrected to 0 M ionic strength by Uchimiya *et al.* 2006 [301]. For temperature, please refer to Martell *et al.* 2004 [300].

## B6 Complex formation constants for Fe(III) and organic anions at 25 °C, I = 0 M\*

| No.         | Complexes   | log $\beta^a$ | Condition      | Reference |
|-------------|---|---------------|----------------|-----------|
| <b>B6.1</b> | Fe <sup>III</sup> Ace <sup>2+</sup>                                 | 3.2           | 20 °C, I = 1 M | [291]     |
|             |   | 4.0           |                | [79]      |
| <b>B6.2</b> | Fe <sup>III</sup> (Ace) <sub>2</sub> <sup>+</sup>                   | 7.6           |                | [79]      |
| <b>B6.3</b> | Fe <sup>III</sup> (Ace) <sub>3</sub>                                | 9.6           |                | [79]      |
| <b>B6.4</b> | Fe <sup>III</sup> Cit   | 13.5          |                | [79]      |
| <b>B6.5</b> | Fe <sup>III</sup> (OH) <sub>2</sub> (Cit) <sub>2</sub> <sup>-</sup> | 56.3          |                | [79]      |

(continued)

| No.          | Complexes   | log $\beta^a$ | Condition            | Reference  |
|--------------|---|---------------|----------------------|------------|
| <b>B6.6</b>  | Fe <sup>III</sup> EDTA <sup>-</sup>                             | 24.2          | 20–25 °C, I ~ 0 M    | [291]      |
|              |   | 27.7          |                      | [79]       |
| <b>B6.7</b>  | Fe <sup>III</sup> HEDTA   | 29.2          |                      | [79]       |
| <b>B6.8</b>  | Fe <sup>III</sup> OHEDTA <sup>2-</sup>                          | 33.8          |                      | [79]       |
| <b>B6.9</b>  | Fe <sup>III</sup> (OH) <sub>2</sub> EDTA <sup>3-</sup>          | 37.7          |                      | [79]       |
| <b>B6.10</b> | Fe <sup>III</sup> Glu <sup>+</sup>                              | 13.8          |                      | [79]       |
| <b>B6.11</b> | Fe <sup>III</sup> Gly <sup>2+</sup>                             | 3.7           |                      | [79]       |
| <b>B6.12</b> | Fe <sup>III</sup> OHGly <sup>+</sup>                            | 19.6          |                      | [79]       |
| <b>B6.13</b> | Fe <sup>III</sup> OH(Gly) <sub>2</sub>                          | 22.3          |                      | [79]       |
| <b>B6.14</b> | Fe <sup>III</sup> OH(Gly) <sub>3</sub> <sup>-</sup>             | 23.8          |                      | [79]       |
| <b>B6.15</b> | Fe <sup>III</sup> Lac <sup>2+</sup>                             | 7.1           | 20–25 °C, I ~ 0 M    | [291]      |
| <b>B6.16</b> | Fe <sup>III</sup> Mal <sup>+</sup>                              | 9.1           | I = 0 M <sup>b</sup> | [300, 301] |
|              |   | 9.3           |                      | [79]       |
| <b>B6.17</b> | Fe <sup>III</sup> (Mal) <sub>2</sub> <sup>-</sup>               | 15.4          | I = 0 M <sup>b</sup> | [300, 301] |
| <b>B6.18</b> | Fe <sup>III</sup> (Mal) <sub>3</sub> <sup>3-</sup>              | 18.8          | I = 0 M <sup>b</sup> | [300, 301] |
| <b>B6.19</b> | Fe <sup>III</sup> Oxa <sup>+</sup>                              | 8.8           | I = 0 M <sup>b</sup> | [300, 301] |
|              |   | 9.4           | 20–25 °C, I ~ 0 M    | [291]      |
|              |   | 9.4           |                      | [312]      |
| <b>B6.20</b> | Fe <sup>III</sup> (Oxa) <sub>2</sub> <sup>-</sup>               | 15.4          | I = 0 M <sup>b</sup> | [300, 301] |
|              |   | 16.2          | 20–25 °C, I ~ 0 M    | [291]      |
|              |   | 16.2          |                      | [312]      |
| <b>B6.21</b> | Fe <sup>III</sup> (Oxa) <sub>3</sub> <sup>3-</sup>              | 19.8          | I = 0 M <sup>b</sup> | [300, 301] |
|              |   | 20.2          | 20–25 °C, I ~ 0 M    | [291]      |
|              |   | 20.8          |                      | [312]      |
| <b>B6.22</b> | Fe <sup>III</sup> HOxa <sup>2+</sup>                            | 4.4           |                      | [313]      |
| <b>B6.23</b> | Fe <sup>III</sup> C <sub>6</sub> H <sub>5</sub> O <sup>2+</sup> | 7.6           | I = 0.1 M            | [107]      |
| <b>B6.24</b> | Fe <sup>III</sup> Sal <sup>+</sup>                              | 16.3          | I = 0.7 M            | [305]      |
|              |   | 17.6          |                      | [79]       |
| <b>B6.25</b> | Fe <sup>III</sup> (Sal) <sub>2</sub> <sup>-</sup>               | 28.6          |                      | [79]       |
|              |   | 28.8          | I = 0.7 M            | [305]      |
| <b>B6.26</b> | Fe <sup>III</sup> (Sal) <sub>3</sub> <sup>3-</sup>              | 36.2          |                      | [79]       |
| <b>B6.27</b> | Fe <sup>III</sup> HSal <sup>2+</sup>                            | 4.1           | I = 0.7 M            | [305]      |

\*Ace = acetate (CH<sub>3</sub>COO<sup>-</sup>), Cit = citrate (C<sub>3</sub>H<sub>5</sub>O(COO)<sub>3</sub><sup>3-</sup>), EDTA = ethylenediaminetetraacetate (C<sub>6</sub>H<sub>12</sub>N<sub>2</sub>(COO<sup>-</sup>)<sub>4</sub><sup>4-</sup>), Glu = glutamate (<sup>-</sup>OOC(NH<sub>2</sub>)C<sub>3</sub>H<sub>5</sub>COO<sup>-</sup>), Gly = glycolate (CH<sub>2</sub>OHCOO<sup>-</sup>), Lac = lactate (CH<sub>3</sub>CH(OH)COO<sup>-</sup>), Mal = malonate (CH<sub>2</sub>(COO)<sub>2</sub><sup>2-</sup>), Oxa = oxalate (C<sub>2</sub>O<sub>4</sub><sup>2-</sup>), Sal = salicylate (C<sub>6</sub>H<sub>4</sub>(O<sup>-</sup>)COO<sup>-</sup>).

<sup>a</sup>Complex formation constant  $\beta = [M_V(H)_W(OH)_X L_Y^{Z\pm}] / [M^{a+}]^V [L^{b-}]^Y [OH^-]^X [H^+]^W$ , all concentrations in the unit of M.

<sup>b</sup>Corrected to 0 M ionic strength by Uchimiya *et al.* 2006 [301]. For temperature, please refer to Martell *et al.* 2004 [300].

**B7 Reduction potential of sulphur oxide radicals and molecules at 25 °C\***

| No.          | Oxidant State | Half cell reaction   | $E_H(V)$ | Condition        | Reference |
|--------------|---------------|--|----------|------------------|-----------|
| <b>B7.1</b>  | S(IX)         | $SO_5^{\bullet-} + e^- + H^+ \rightarrow HSO_5^-$            | 1.1      | pH = 7           | [58]      |
| <b>B7.2</b>  |               | $SO_5^{\bullet-} + e^- \rightarrow SO_5^{2-}$                | 0.81     | pH = 11, 21 °C   | [57]      |
| <b>B7.3</b>  | S(VIII)       | $HSO_5^- + 2e^- + 2H^+ \rightarrow HSO_4^- + H_2O$           | 1.81     | pH = 0           | [106]     |
|              |               |  | 1.84     |                  | [279]     |
| <b>B7.4</b>  |               | $HSO_5^- + 2e^- + H^+ \rightarrow SO_4^{2-} + H_2O$          | 1.75     | pH = 0           | [36]      |
| <b>B7.5</b>  | S(VII)        | $SO_4^{\bullet-} + e^- \rightarrow SO_4^{2-}$                | 2.43     |                  | [314]     |
|              |               |  | 2.6      | pH = 0           | [315]     |
| <b>B7.6</b>  |               | $S_2O_8^{2-} + e^- \rightarrow S_2O_8^{3-}$                  | ~0.1     |                  | [316]     |
| <b>B7.7</b>  |               | $S_2O_8^{2-} + 2e^- \rightarrow 2SO_4^{2-}$                  | 2.0      | pH = 0           | [317]     |
| <b>B7.8</b>  |               | $S_2O_8^{2-} + 2H^+ + 2e^- \rightarrow 2HSO_4^-$             | 2.1      | pH = 0           | [292]     |
| <b>B7.9</b>  | S(VI)         | $SO_4^{2-} + H_2O + e^- \rightarrow SO_3^{\bullet-} + 2OH^-$ | -2.47    | pH > 7.2         | [58]      |
| <b>B7.10</b> |               | $SO_4^{2-} + H_2O + 2e^- \rightarrow SO_3^{2-} + 2OH^-$      | -0.93    | pH = 0           | [292]     |
| <b>B7.11</b> |               | $2SO_4^{2-} + 4H^+ + 2e^- \rightarrow S_2O_6^{2-} + 2H_2O$   | -0.22    | pH = 0           | [292]     |
| <b>B7.12</b> |               | $SO_3 + e^- \rightarrow SO_3^{\bullet-}$                     | 0.25     |                  | [279]     |
| <b>B7.13</b> |               | $SO_4^{2-} + 4H^+ + 2e^- \rightarrow H_2SO_3 + H_2O$         | 0.17     | pH = 0           | [292]     |
| <b>B7.14</b> |               | $HSO_4^- + 2H^+ + 2e^- \rightarrow H_2SO_3 + OH^-$           | 0.10     |                  | [318]     |
| <b>B7.15</b> | S(V)          | $SO_3^{\bullet-} + e^- = SO_3^{2-}$                          | 0.63     | pH > 7           | [58]      |
|              |               |  | 0.84     | pH = 3.6         | [58]      |
|              |               |  | 0.73     | pH = 11.5, 21 °C | [57]      |
|              |               |  | 0.72     | pH = 0           | [319]     |
| <b>B7.16</b> |               | $S_2O_6^{2-} + 4H^+ + 2e^- \rightarrow 2H_2SO_3$             | 0.56     |                  | [292]     |
| <b>B7.17</b> | S(IV)         | $2SO_3^{2-} + 2H_2O + 2e^- \rightarrow S_2O_4^{2-} + 4OH^-$  | -1.12    | pH = 0           | [292]     |
| <b>B7.18</b> |               | $2SO_3^{2-} + 3H_2O + 4e^- \rightarrow S_2O_3^{2-} + 6OH^-$  | -0.57    | pH = 0           | [292]     |
| <b>B7.19</b> |               | $2H_2SO_3 + H^+ + 2e^- \rightarrow HS_2O_4^- + 2H_2O$        | -0.06    | pH = 0           | [292]     |
| <b>B7.20</b> | S(V/II)       | $S_2O_3^{\bullet-} + e^- \rightarrow S_2O_3^{2-}$            | 1.34     | pH = 0           | [319]     |
| <b>B7.21</b> |               | $S_4O_6^{2-} + 2e^- + 2H^+ \rightarrow 2HS_2O_3^-$           | 0.1      | pH = 0           | [318]     |
| <b>B7.22</b> | S(IX/IV)      | $S_4O_6^{\bullet3-} + e^- \rightarrow 2S_2O_3^{2-}$          | 1.07     | pH ≥ 8.8         | [57]      |
|              |               |  | 1.13     | pH = 0           | [319]     |

\* $E_H$  of  $SO_5^{\bullet-}$  and  $SO_3^{\bullet-}$  at other pH can be calculated from:  $E_{pH} = E_{pH=0} + 0.059 \log\{(K_{a1}K_{a2} + K_{a1}[H^+] + [H^+]^2)/(K_{ar} + [H^+])\}$ , where  $E_{pH}$  = redox potential at pH of interest,  $K_{a1}$ ,  $K_{a2}$  are the 1st and 2nd acid dissociation constants of  $H_2SO_4$ ,  $K_{ar}$  = acid dissociation constant of  $HSO_x$  radical estimated to be  $10^{-2}$  M. For reference, see Huie and Neta (1984) [58] and Das *et al.* (1999) [57].



**B8 Standard reduction potential of important aqueous oxidants at 25 °C**

| No.          | Half cell reaction   | $E_{\text{H}}^{\circ}$ (V) | Reference |
|--------------|--|----------------------------|-----------|
| <b>B8.1</b>  | $\text{HO}^{\bullet} + \text{e}^{-} \rightarrow \text{OH}^{-}$                         | 1.9                        | [297]     |
|              |  | 2.02                       | [217]     |
| <b>B8.2</b>  | $\text{HO}^{\bullet} + \text{e}^{-} + \text{H}^{+} \rightarrow \text{H}_2\text{O}$     | 2.7                        | [297]     |
| <b>B8.3</b>  | $\text{O}_3 + \text{e}^{-} \rightarrow \text{O}_3^{-}$                                 | 1.0                        | [80]      |
| <b>B8.4</b>  | ${}^1\text{O}_2 + \text{e}^{-} \rightarrow \text{O}_2^{\bullet -}$                     | 0.83                       | [80]      |
| <b>B8.5</b>  | ${}^3\text{O}_2 + \text{e}^{-} \rightarrow \text{O}_2^{\bullet -}$                     | -0.16                      | [80]      |
| <b>B8.6</b>  | $\text{H}_2\text{O}_2 + 2\text{e}^{-} + 2\text{H}^{+} \rightarrow 2\text{H}_2\text{O}$ | 1.77                       | [79]      |
| <b>B8.7</b>  | $\text{HO}_2^{\bullet} + \text{e}^{-} \rightarrow \text{HO}_2^{-}$                     | 0.75                       | [80]      |
| <b>B8.8</b>  | $\text{O}_2^{\bullet -} + \text{e}^{-} + \text{H}^{+} \rightarrow \text{HO}_2^{-}$     | 1.03 <sup>a</sup>          | [80]      |
| <b>B8.9</b>  | $\text{CO}_3^{\bullet -} + \text{e}^{-} \rightarrow \text{CO}_3^{2-}$                  | 1.6                        | [80]      |
| <b>B8.10</b> | $\text{Cl}_2^{\bullet -} + \text{e}^{-} \rightarrow 2\text{Cl}^{-}$                    | 2.09                       | [320]     |
| <b>B8.11</b> | $\text{ClO}_2^{\bullet} + \text{e}^{-} \rightarrow \text{ClO}_2^{-}$                   | 0.93                       | [279]     |
| <b>B8.12</b> | $\text{Br}_2^{\bullet -} + \text{e}^{-} \rightarrow 2\text{Br}^{-}$                    | 1.62                       | [320]     |
| <b>B8.13</b> | $\text{I}_2^{\bullet -} + \text{e}^{-} \rightarrow 2\text{I}^{-}$                      | 1.03                       | [320]     |
| <b>B8.14</b> | $\text{N}_3^{\bullet} + \text{e}^{-} \rightarrow \text{N}_3^{-}$                       | 1.35                       | [320]     |
| <b>B8.15</b> | $\text{NO}_2 + \text{e}^{-} \rightarrow \text{NO}_2^{-}$                               | 1.03                       | [270]     |
| <b>B8.16</b> | $\text{NO}_3 + \text{e}^{-} \rightarrow \text{NO}_3^{-}$                               | 2.3                        | [270]     |
| <b>B8.17</b> | $\text{ArO}^{\bullet} + \text{e}^{-} \rightarrow \text{ArO}^{-}$                       | 0.79                       | [80]      |

<sup>a</sup>Calculated from acid dissociation constant  $\text{pK}_a$  of  $\text{HO}_2^{\bullet} = 4.8$ , according to Kwan *et al.* 2003 [259].

**B9  $\Delta G_{\text{f}}^{\circ}$  and  $\Delta H_{\text{f}}^{\circ}$  of some sulphur oxide radicals and ions at 25 °C**

| No.          | Aqueous species             | $\Delta G_{\text{f}}^{\circ}$ (kJ mol <sup>-1</sup> ) | $\Delta H_{\text{f}}^{\circ}$ (kJ mol <sup>-1</sup> ) | Reference |
|--------------|-----------------------------|---|---|-----------|
| <b>B9.1</b>  | $\text{H}_2\text{O}$        | -237.13   |   | [321]     |
|              |                             |   | -285.83   | [78]      |
| <b>B9.2</b>  | $\text{HSO}_3^{-}$          | -527.7  |   | [321]     |
| <b>B9.3</b>  | $\text{SO}_4^{2-}$          | -744.5  |   | [321]     |
|              |                             |   | -909.27   | [78]      |
| <b>B9.4</b>  | $\text{S}_2\text{O}_6^{2-}$ | -1004   | -1198.4   | [322]     |
| <b>B9.5</b>  | $\text{S}_2\text{O}_7^{2-}$ | -1193   |   | [121]     |
| <b>B9.6</b>  | $\text{S}_2\text{O}_8^{2-}$ | -1114.9   |   | [321]     |
|              |                             |   | -1344.7   | [322]     |
| <b>B9.7</b>  | $\text{HSO}_5^{-}$          | -638  |   | [323]     |
| <b>B9.8</b>  | $\text{SO}_2^{\bullet -}$   |   | -326.5  | [322]     |
| <b>B9.9</b>  | $\text{SO}_3^{\bullet -}$   | -426  |   | [58]      |
|              |                             |   | -501.9  | [322]     |
| <b>B9.10</b> | $\text{SO}_4^{\bullet -}$   | -510.6  |   | [279]     |
|              |                             |   | -607.7  | [322]     |
| <b>B9.11</b> | $\text{SO}_5^{\bullet -}$   | -493  |   | [58]      |
|              |                             |   | -486.6  | -605.4    |

**B10**  $\Delta E_{\text{H}}^{\circ}$  for the formation of  $\text{SO}_3^{\bullet-}$  from  $\text{Me}^{n+}$ -induced S(IV) oxidation at 25 °C

| No.           | $^{\text{a}}\text{Me}^{n+}/\text{Me}^{(n-1)+}$ | $E_{\text{H}}^{\circ}(\text{Me}^{n+}/\text{Me}^{(n-1)+})(\text{V})$ | $\Delta E_{\text{H}}^{\circ}(\text{V})^{\text{b}}$ | $\Delta E_{\text{H}}^{\circ}(\text{V})^{\text{c}}$ |
|---------------|--|---|--|--|
| <b>B10.1</b>  | $\text{Ag}^{3+}/\text{Ag}^{2+}$                | 1.8 <sup>d</sup>  | 0.96   | 0.66   |
| <b>B10.2</b>  | $\text{Ag}^{2+}/\text{Ag}^{+}$                 | 1.99 <sup>d</sup>   | 1.15   | 0.85   |
| <b>B10.3</b>  | $\text{Ce}^{4+}/\text{Ce}^{3+}$                | 1.72 <sup>e</sup>   | 0.88   | 0.58   |
| <b>B10.4</b>  | $\text{Co}^{3+}/\text{Co}^{2+}$                | 1.92 <sup>e</sup>   | 1.04   | 0.74   |
| <b>B10.5</b>  | $\text{Cr}^{3+}/\text{Cr}^{2+}$                | -0.41 <sup>e</sup>  | -1.25  | -0.95  |
| <b>B10.6</b>  | $\text{Cu}^{3+}/\text{Cu}^{2+}$                | 2.4 <sup>e</sup>  | 1.56   | 1.26   |
| <b>B10.7</b>  | $\text{Cu}^{2+}/\text{Cu}^{+}$                 | 0.15 <sup>e</sup>   | -0.69  | -0.99  |
| <b>B10.8</b>  | $\text{Fe}^{3+}/\text{Fe}^{2+}$                | 0.77 <sup>e</sup>   | -0.07  | -0.37  |
| <b>B10.9</b>  | $\text{Mn}^{2+}/\text{Mn}^{+}$                 | -4.46 <sup>f</sup>  | -5.3   | -5.6   |
| <b>B10.10</b> | $\text{Mn}^{3+}/\text{Mn}^{2+}$                | 1.54 <sup>e</sup>   | 0.7  | 0.4  |
| <b>B10.11</b> | $\text{Ni}^{3+}/\text{Ni}^{2+}$                | 2.3 <sup>d</sup>  | 1.46   | 1.16   |
| <b>B10.12</b> | $\text{Ti}^{3+}/\text{Ti}^{2+}$                | -0.9 <sup>e</sup>   | -1.74  | -2.04  |
| <b>B10.13</b> | $\text{V}^{3+}/\text{V}^{2+}$                  | -0.26 <sup>e</sup>  | -1.1   | -1.4   |

<sup>a</sup> $\text{Me}^{n+} + \text{e}^{-} \rightarrow \text{Me}^{(n-1)+}$ .

<sup>b</sup> $\Delta E_{\text{H}}^{\circ}$  for  $\text{Me}^{n+} + \text{SO}_3^{\bullet-} \rightarrow \text{Mn}^{(n-1)+} + \text{SO}_3^{\bullet-}$ , with  $E_{\text{H}}^{\circ}(\text{SO}_3^{\bullet-} \rightarrow \text{SO}_3^{\bullet-} + \text{e}^{-}) \sim -0.84 \text{ V}$ .

<sup>c</sup> $\Delta E_{\text{H}}^{\circ}$  for  $\text{Me}^{n+} + \text{SO}_3^{\bullet-} \rightarrow \text{Mn}^{(n-1)+} + \text{SO}_3^{\bullet-}$ , with  $E_{\text{H}}^{\circ}(\text{SO}_3^{\bullet-} \rightarrow \text{SO}_3^{\bullet-} + \text{e}^{-}) - 1.14 \text{ V}$  is the pH-corrected redox potential at  $[\text{H}^{+}] = 1 \text{ M}$  from  $-0.84 \text{ V}$  (at pH 3.6) (Huie and Neta) and  $-0.73 \text{ V}$  (at pH 11.5) (Das *et al.* 1999) using the equation beneath B.7.

<sup>d</sup>ref. [318].

<sup>e</sup>ref. [292].

<sup>f</sup>ref. [141].

**Appendix C: Kinetic data related to aqueous Fe-S(IV)-O<sub>2</sub> system****C1** Rate constants for elementary reactions involving S(IV) transformations

| No.         | Elementary reaction   | $k(\text{M}^{-1}\text{s}^{-1});$<br>( $E_{\text{a}}$ in $\text{kJ mol}^{-1}$ ) | Condition | Reference |
|-------------|---|--|-----------|-----------|
| <b>C1.1</b> | $\text{HSO}_3^{-} + \text{OH}^{\bullet} \rightarrow \text{SO}_3^{\bullet-} + \text{H}_2\text{O}$          | $2.7 \times 10^9$  | pH 4.5    | [324]     |
|             |   | $2.7 \times 10^9$  |           | [325]     |
|             |   | $4.2 \times 10^9$  |           | [217]     |
|             |   | $4.5 \times 10^9$  |           | [326]     |
|             |   | $9.5 \times 10^9$  |           | [4]       |
| <b>C1.2</b> | $\text{SO}_3^{\bullet-} + \text{OH}^{\bullet} \rightarrow \text{SO}_3^{\bullet-} + \text{OH}^{-}$         | $2.7 \times 10^9$  | pH 4.5    | [304]     |
|             |   | $4.1 \times 10^9$  | pH 9.0    | [304]     |
|             |   | $4.5 \times 10^9$  | pH 4.4    | [327]     |
|             |   | $4.6 \times 10^9$  | pH 8.5    | [217]     |
|             |   | $5.2 \times 10^9$  | pH 11.2   | [327]     |
|             |   | $5.4 \times 10^9$  |           | [326]     |
|             | $5.5 \times 10^9$   |  | [4]       |           |
| <b>C1.3</b> | $\text{HSO}_3^{-} + \text{O}_3 \rightarrow \text{HSO}_4^{-} + \text{O}_2$                                 | $3.7 \times 10^5 (E_{\text{a}} = 46)$  |           | [328]     |
| <b>C1.4</b> | $\text{SO}_3^{\bullet-} + \text{O}_3 \rightarrow \text{SO}_4^{\bullet-} + \text{O}_2$                     | $1.5 \times 10^9 (E_{\text{a}} = 44)$  |           | [328]     |
| <b>C1.5</b> | $\text{SO}_2 + \text{O}_3 (+\text{H}_2\text{O}) \rightarrow \text{HSO}_4^{-} + \text{O}_2 + \text{H}^{+}$ | $2.4 \times 10^4$  |           | [328]     |

(continued)

| No.          | Elementary reaction   | $k(\text{M}^{-1}\text{s}^{-1});$<br>( $E_a$ in $\text{kJ mol}^{-1}$ ) | Condition     | Reference |
|--------------|---|---|---------------|-----------|
| <b>C1.6</b>  | $\text{HSO}_3^- + \text{HO}_2^* \rightarrow \text{SO}_5^{*-} + \text{products}$   | $<2 \times 10^1$  |               | [272]     |
| <b>C1.7</b>  | $\text{HSO}_3^- + \text{H}_2\text{O}_2 \rightarrow \text{SO}_4^{2-} + \text{H}_2\text{O} + \text{H}^+$  | $\sim 1 \times 10^3$  |               | [144]     |
| <b>C1.8</b>  | $\text{HSO}_3^- + \text{CH}_3\text{OOH} \rightarrow \text{SO}_4^{2-} + \text{CH}_3\text{OH} + \text{H}^+$   | $6.9 \times 10^7$ ( $E_a = 33$ )                                      |               | [329]     |
| <b>C1.9</b>  | $2\text{HSO}_3^- \rightarrow \text{S}_2\text{O}_5^{2-} + \text{H}_2\text{O}$  | $1.8 \times 10^7$ ( $E_a = 32$ )                                      | 25 °C         | [329]     |
| <b>C1.10</b> | $\text{HSO}_3^- + \text{SO}_4^{*-} \rightarrow \text{SO}_4^{2-} + \text{SO}_3^{*-} + \text{H}^+$  | $7 \times 10^2$   |               | [96]      |
|              |   | $1.3 \times 10^8$   |               | [55]      |
|              |   | $4.6 \times 10^8$   |               | [327]     |
|              |   | $5.3 \times 10^8$   | pH > 7        | [55]      |
|              |   | $6.8 \times 10^8$   | pH 4, I = 0 M | [185]     |
|              |   | $7.5 \times 10^8$   |               | [330]     |
|              |   | $2.0 \times 10^9$   | pH 8.7        | [327]     |
|              |   | $2.5 \times 10^9$   |               | [269]     |
| <b>C1.11</b> | $\text{SO}_3^{2-} + \text{SO}_4^{*-} \rightarrow \text{SO}_4^{2-} + \text{SO}_3^{*-}$   | $3.1 \times 10^8$ ( $E_a = 9.6$ )                                     | I = 0 M       | [184]     |
|              |   | $3.2 \times 10^8$ ( $E_a = 10$ )                                      |               | [331]     |
|              |   | $5.5 \times 10^8$   | pH 8.0        | [38]      |
| <b>C1.12</b> | $\text{HSO}_3^- + \text{SO}_5^{*-} \rightarrow \text{HSO}_5^- + \text{SO}_3^{*-}$<br>$\rightarrow \text{H}^+ + \text{SO}_4^{2-} + \text{SO}_4^{*-}$   | $3.6 \times 10^3$   |               | [272]     |
| <b>C1.13</b> | $\text{HSO}_3^- + \text{SO}_5^{*-} \rightarrow \text{HSO}_5^- + \text{SO}_3^{*-}$   | $8.5 \times 10^3$   |               | [144]     |
|              |   | $8.6 \times 10^3$   |               | [185]     |
|              |   | $2.5 \times 10^4$   | pH 4.9        | [327]     |
|              |   | $7.5 \times 10^4$   |               | [332]     |
|              |   | $<3.0 \times 10^5$  |               | [327]     |
|              |   | $3.0 \times 10^6$   | pH 6.8        | [58]      |
|              |   | $1.3 \times 10^7$   | pH 8.7        | [327]     |
| <b>C1.14</b> | $\text{SO}_3^{2-} + \text{SO}_5^{*-} (+\text{H}^+) \rightarrow \text{HSO}_5^- + \text{SO}_3^{*-}$   | $2.1 \times 10^5$   | acidic        | [185]     |
|              |   | $3.0 \times 10^6$   |               | [38]      |
|              |   | $3.8 \times 10^6$   |               | [332]     |
| <b>C1.15</b> | $\text{SO}_3^{2-} + \text{SO}_5^{*-} \rightarrow \text{SO}_5^{2-} + \text{SO}_3^{*-}$   | $3.6 \times 10^5$   | pH 9          | [185]     |
| <b>C1.16</b> | $\text{HSO}_3^- + \text{SO}_5^{*-} \rightarrow \text{HSO}_4^- + \text{SO}_4^{*-}$<br>(or $\text{HSO}_3^- + \text{SO}_5^{*-} \rightarrow \text{H}^+ + \text{SO}_4^{2-} + \text{SO}_4^{*-}$ ) | $3.6 \times 10^2$   |               | [185]     |
|              |   | $2.5 \times 10^4$   | pH 4.9        | [332]     |
|              |   | $<3.0 \times 10^5$  |               | [327]     |
|              |   | $1.3 \times 10^7$   |               | [67]      |
|              |   | $3.0 \times 10^8$   |               | [144]     |
| <b>C1.17</b> | $\text{SO}_3^{2-} + \text{SO}_5^{2-} \rightarrow \text{SO}_4^{2-} + \text{SO}_4^{*-}$   | $1.3 \times 10^5$   |               | [163]     |
|              |   | $1.4 \times 10^5$   | pH 9          | [185]     |
| <b>C1.18</b> | $\text{SO}_3^{2-} + \text{SO}_5^{*-} (+\text{H}^+) \rightarrow \text{HSO}_4^- + \text{SO}_4^{*-}$   | $7.5 \times 10^4$   |               | [327]     |
|              |   | $5.5 \times 10^6$   |               | [185]     |
|              |   | $9.0 \times 10^6$   |               | [332]     |
|              |   | $1.0 \times 10^7$   |               | [38]      |
| <b>C1.19</b> | $\text{HSO}_3^- + \text{HSO}_5^- \rightarrow 2\text{SO}_4^{2-} + 2\text{H}^+$   | $\sim 1 \times 10^3$  |               | [144]     |
| <b>C1.20</b> | $\text{HSO}_3^- + \text{HSO}_5^- + \text{H}^+ \rightarrow 2\text{HSO}_4^- + \text{H}^+$   | $5.6 \times 10^6$   |               | [217]     |
| <b>C1.21</b> | $\text{HSO}_3^- + \text{HSO}_5^- \rightarrow 2\text{HSO}_4^-$   | $3.5 \times 10^2$   | pH 8.0        | [38]      |
|              |   | $9.1 \times 10^3$   | pH 2.9        | [217]     |
|              |   | $2.0 \times 10^4$   | pH 2.5        | [217]     |
|              |   | $7.9 \times 10^4$   | pH 1.5        | [217]     |
|              |   | $7.5 \times 10^5$   |               | [12]      |
| <b>C1.22</b> | $\text{HSO}_3^- + \text{NO}_2 \rightarrow \text{NO}_2^- + \text{HSO}_3^*$   | $1.5 \times 10^4$   | 25 °C         | [333]     |

(continued)

| No.   | Elementary reaction   | k(M <sup>-1</sup> s <sup>-1</sup> );<br>(E <sub>a</sub> in kJ mol <sup>-1</sup> ) | Condition         | Reference |
|-------|---|---|-------------------|-----------|
| C1.23 | SO <sub>3</sub> <sup>2-</sup> + NO <sub>2</sub> → NO <sub>2</sub> <sup>-</sup> + SO <sub>3</sub> <sup>•-</sup>  | 2.8 × 10 <sup>4</sup>   | 55 °C             | [12]      |
|       |   | 6.6 × 10 <sup>5</sup>   | 25 °C             | [333]     |
| C1.24 | S(IV) + 2NO <sub>2</sub> (+OH <sup>-</sup> )<br>→ 2NO <sub>2</sub> <sup>-</sup> + S(VI) + H <sup>+</sup>  | 1.1 × 10 <sup>6</sup>   | 55 °C             | [12]      |
|       |   | 1.1 × 10 <sup>7</sup>   | pH 5.3, I = 0.5 M | [232]     |
|       |   | 2.9 × 10 <sup>7</sup>   | pH 13, I = 0.5 M  | [232]     |
| C1.25 | HSO <sub>3</sub> <sup>-</sup> + Cl <sup>•</sup> → Cl <sup>-</sup> + H <sup>+</sup> + SO <sub>3</sub> <sup>•-</sup>  | 1.0 × 10 <sup>9</sup>   |                   | [54]      |
| C1.26 | HSO <sub>3</sub> <sup>-</sup> + Cl <sub>2</sub> <sup>•-</sup> → 2Cl <sup>-</sup> + H <sup>+</sup> + SO <sub>3</sub> <sup>•-</sup>                                   | 1.7 × 10 <sup>8</sup> (E <sub>a</sub> = 3)  |                   | [334]     |
|       |   | 1.8 × 10 <sup>8</sup>   |                   | [335]     |
| C1.27 | SO <sub>3</sub> <sup>2-</sup> + Cl <sub>2</sub> <sup>•-</sup> → 2Cl <sup>-</sup> + SO <sub>3</sub> <sup>•-</sup>  | 4.7 × 10 <sup>8</sup> (E <sub>a</sub> = 9)  | 25 °C, I = 0.1 M  | [320]     |
|       |   | 6.2 × 10 <sup>7</sup>   |                   | [334]     |
|       |   | 5.0 × 10 <sup>8</sup>   |                   | [54]      |
| C1.28 | HSO <sub>3</sub> <sup>-</sup> + Br <sub>2</sub> <sup>•-</sup> → 2Br <sup>-</sup> + H <sup>+</sup> + SO <sub>3</sub> <sup>•-</sup>                                   | 6.3 × 10 <sup>7</sup> (E <sub>a</sub> = 6.5)                                      | 25 °C, I = 0.1 M  | [320]     |
| C1.29 | SO <sub>3</sub> <sup>2-</sup> + Br <sub>2</sub> <sup>•-</sup> → 2Br <sup>-</sup> + SO <sub>3</sub> <sup>•-</sup>  | 2.2 × 10 <sup>8</sup> (E <sub>a</sub> = 5.4)                                      | 25 °C, I = 0.1 M  | [320]     |
| C1.30 | HSO <sub>3</sub> <sup>-</sup> + I <sub>2</sub> <sup>•-</sup> → 2I <sup>-</sup> + H <sup>+</sup> + SO <sub>3</sub> <sup>•-</sup>                                     | 1.4 × 10 <sup>6</sup> (E <sub>a</sub> = 19)                                       | 25 °C, I = 0.1 M  | [320]     |
| C1.31 | SO <sub>3</sub> <sup>2-</sup> + I <sub>2</sub> <sup>•-</sup> → 2I <sup>-</sup> + SO <sub>3</sub> <sup>•-</sup>  | 1.7 × 10 <sup>8</sup> (E <sub>a</sub> = 12)                                       | 25 °C, I = 0.1 M  | [320]     |
| C1.32 | HSO <sub>3</sub> <sup>-</sup> + CO <sub>3</sub> <sup>•-</sup> → CO <sub>3</sub> <sup>2-</sup> + H <sup>+</sup> + SO <sub>3</sub> <sup>•-</sup>                      | Est1 × 10 <sup>7</sup>  |                   | [69]      |
| C1.33 | SO <sub>3</sub> <sup>2-</sup> + CO <sub>3</sub> <sup>•-</sup> → CO <sub>3</sub> <sup>2-</sup> + SO <sub>3</sub> <sup>•-</sup>                                       | 5.0 × 10 <sup>6</sup> (E <sub>a</sub> = 3.9)                                      |                   | [336]     |
| C1.34 | HSO <sub>3</sub> <sup>-</sup> + Mn <sup>3+</sup> → Mn <sup>2+</sup> + H <sup>+</sup> + SO <sub>3</sub> <sup>•-</sup>  | 1.3 × 10 <sup>6</sup>   |                   | [76]      |
| C1.35 | SO <sub>3</sub> <sup>2-</sup> + Cu <sup>2+</sup> → Cu <sup>+</sup> + SO <sub>3</sub> <sup>•-</sup>  | 3.6 × 10 <sup>-3</sup>  |                   | [126]     |
| C1.36 | [Cu <sup>II</sup> S <sup>IV</sup> O <sub>3</sub> Cu <sup>II</sup> ] <sup>2+</sup> → [Cu <sup>II</sup> S <sup>V</sup> O <sub>3</sub> Cu <sup>I</sup> ] <sup>2+</sup> | 5.7 × 10 <sup>-3</sup> s <sup>-1</sup>  |                   | [72]      |

## C2 Rate constants for elementary reactions involving SO<sub>X</sub><sup>•-</sup> and SO<sub>5</sub><sup>2-</sup> transformations

| No.   | Elementary reaction  | k(M <sup>-1</sup> s <sup>-1</sup> );<br>(E <sub>a</sub> in kJ mol <sup>-1</sup> ) | Condition | Reference |
|-------|--|---|-----------|-----------|
| C2.1  | SO <sub>3</sub> <sup>•-</sup> + O <sub>2</sub> → +SO <sub>5</sub> <sup>2-</sup>  | 1.1 × 10 <sup>9</sup>   |           | [269]     |
|       |  | 1.5 × 10 <sup>9</sup>   |           | [217]     |
|       |  | 2.5 × 10 <sup>9</sup>   |           | [185]     |
| C2.2  | SO <sub>4</sub> <sup>•-</sup> + •OH → HSO <sub>4</sub> <sup>-</sup>  | 9.0 × 10 <sup>9</sup>   | I = 0 M   | [185]     |
|       |  | 1.0 × 10 <sup>10</sup>  | 25 °C     | [54]      |
| C2.3  | SO <sub>4</sub> <sup>•-</sup> + •H → +HSO <sub>4</sub> <sup>-</sup>  | 6.8 × 10 <sup>9</sup>   | I = 0 M   | [185]     |
| C2.4  | SO <sub>4</sub> <sup>•-</sup> + O <sub>2</sub> <sup>•-</sup> → +SO <sub>4</sub> <sup>2-</sup> + O <sub>2</sub>                                 | 3.5 × 10 <sup>9</sup>   |           | [331]     |
|       |  | 4.0 × 10 <sup>9</sup>   |           | [185]     |
| C2.5  | SO <sub>4</sub> <sup>•-</sup> + HO <sub>2</sub> <sup>•-</sup> → +SO <sub>4</sub> <sup>2-</sup> + H <sup>+</sup> + O <sub>2</sub>               | 3.5 × 10 <sup>9</sup>   |           | [331]     |
| C2.6  | SO <sub>4</sub> <sup>•-</sup> + H <sub>2</sub> O <sub>2</sub> → +SO <sub>4</sub> <sup>2-</sup> + H <sup>+</sup> + HO <sub>2</sub> <sup>•</sup> | 1.2 × 10 <sup>7</sup>   |           | [337]     |
|       |  | 2.8 × 10 <sup>7</sup>   |           | [331]     |
| C2.7  | SO <sub>4</sub> <sup>•-</sup> + H <sub>2</sub> O → +HSO <sub>4</sub> <sup>-</sup> + •OH  | 9.3 × 10 <sup>0</sup>   |           | [338]     |
| C2.8  | SO <sub>4</sub> <sup>•-</sup> (+H <sub>2</sub> O) → •OH + SO <sub>4</sub> <sup>2-</sup>  | 4.4 × 10 <sup>2</sup> s <sup>-1</sup>   |           | [339]     |
|       |  | 5.0 × 10 <sup>2</sup> s <sup>-1</sup>   |           | [325]     |
| C2.9  | SO <sub>4</sub> <sup>•-</sup> + H <sub>2</sub> O → +SO <sub>4</sub> <sup>2-</sup> + H <sup>+</sup> + •OH                                       | 1.1 × 10 <sup>1</sup> (E <sub>a</sub> = 9.2)                                      |           | [338]     |
| C2.10 | SO <sub>4</sub> <sup>•-</sup> + OH <sup>-</sup> → +SO <sub>4</sub> <sup>2-</sup> + •OH   | 1.4 × 10 <sup>7</sup>   |           | [338]     |
|       |  | 2.0 × 10 <sup>7</sup>   | I = 0 M   | [335]     |
|       |  | 6.5 × 10 <sup>7</sup>   |           | [55]      |
|       |  | 7.3 × 10 <sup>7</sup>   | pH 6.8    | [276]     |

(continued)

| No.   | Elementary reaction  | $k$ ( $M^{-1} s^{-1}$ );<br>( $E_a$ in $kJ mol^{-1}$ ) | Condition       | Reference |
|-------|--|--|-----------------|-----------|
| C2.11 | $SO_4^{*-} + S_2O_8^{2-} \rightarrow +SO_4^{2-} + S_2O_8^{*-}$                           | $6.1 \times 10^5$                                      |                 | [325]     |
|       |  | $6.3 \times 10^5$                                      |                 | [338]     |
| C2.12 | $SO_4^{*-} + HSO_5^- \rightarrow +HSO_4^- + SO_5^{*-}$                                   | $1.0 \times 10^6$                                      | 25 °C           | [54]      |
| C2.13 | $SO_4^{*-} + SO_5^{2-} \rightarrow SO_4^{2-} + SO_5^{*-}$                                | $1.0 \times 10^8$                                      | 25 °C           | [54]      |
| C2.14 | $SO_4^{*-} + HSO_3^- \rightarrow SO_4^{2-} + SO_3^{*-} + H^+$                            | $1.3 \times 10^8$                                      |                 | [55]      |
|       |  | $4.6 \times 10^8$                                      |                 | [327]     |
|       |  | $5.3 \times 10^8$                                      | pH > 7          | [55]      |
|       |  | $6.8 \times 10^8$                                      | pH 4, I = 0 M   | [185]     |
|       |  | $7.5 \times 10^8$                                      |                 | [330]     |
|       |  | $2.0 \times 10^9$                                      | pH 8.7          | [327]     |
|       |  | $2.5 \times 10^9$                                      |                 | [269]     |
| C2.15 | $SO_4^{*-} + SO_3^{2-} \rightarrow SO_4^{2-} + SO_3^{*-}$                                | $3.1 \times 10^8$ ( $E_a = 9.6$ )                      | I = 0 M         | [185]     |
|       |  | $3.2 \times 10^8$ ( $E_a = 10$ )                       |                 | [331]     |
| C2.16 | $Cr^{3+} + SO_4^{*-} \leftrightarrow [Cr^{III}(S^{VII}O_4^*)]^-$                         | $K = 7.6 \times 10^2$                                  | pH 8.0          | [38]      |
|       |  | $K = 4.2 \times 10^3$                                  | pH 3            | [268]     |
| C2.17 | $[Cr^{III}(S^{VII}O_4^*)]^- \rightarrow Cr^{IV} + SO_4^{2-}$                             | $k_{ET} = 2.3 \times 10^4$                             | pH 3            | [268]     |
|       |  | $k_{ET} = 1.2 \times 10^4$                             | pH 3.7          | [268]     |
| C2.18 | $SO_4^{*-} + Mn^{2+} \rightarrow Mn^{3+} + SO_4^{2-}$                                    | $1.4 \times 10^7$ ( $E_a = 34$ )                       | 20 °C, pH 3–5   | [52]      |
|       |  | $2.0 \times 10^7$                                      |                 | [270]     |
| C2.19 | $[Mn^{II}(SO_4^*)]^- \rightarrow Mn^{3+} + SO_4^{2-}$                                    | $k_{ET} = 2.6 \times 10^6$                             | 20 °C, pH 3–5   | [52]      |
| C2.20 | $SO_4^{*-} + Ti^{2+} \rightarrow Ti^{3+} + SO_4^{2-}$                                    | $1.7 \times 10^9$                                      |                 | [270]     |
| C2.21 | $SO_4^{*-} + Ag^+ \rightarrow Ag^{2+} + SO_4^{2-}$                                       | $1.8 \times 10^9$                                      |                 | [270]     |
| C2.22 | $SO_4^{*-} + Co^{2+} \rightarrow Co^{3+} + SO_4^{2-}$                                    | $2.0 \times 10^6$                                      |                 | [270]     |
| C2.23 | $SO_4^{*-} + Cl^- \rightarrow SO_4^{2-} + Cl^{\bullet}$                                  | $2 \times 10^8$  |                 | [270]     |
|       |  | $3.0 \times 10^8$                                      | I = 0 M         | [335]     |
|       |  | $3.1 \times 10^8$                                      | pH ~ 6.0        | [276]     |
| C2.24 | $SO_4^{*-} + Br^- \rightarrow SO_4^{2-} + Br^{\bullet}$                                  | $3.0 \times 10^8$ ( $E_a = 0$ )                        | ~25 °C, I = 0 M | [340]     |
|       |  | $2.1 \times 10^9$                                      |                 | [341]     |
|       |  | $3.5 \times 10^9$                                      |                 | [270]     |
| C2.25 | $SO_4^{*-} + N_3^- \rightarrow SO_4^{2-} + N_3^{\bullet}$                                | $2.4 \times 10^9$ ( $E_a = 10$ )                       | 25 °C, I = 0 M  | [340]     |
| C2.26 | $SO_4^{*-} + HCO_3^- \rightarrow SO_4^{2-} + CO_3^{2-} + H^+$                            | $2.8 \times 10^6$ ( $E_a = 17$ )                       | 23 °C, I = 0 M  | [340]     |
| C2.27 | $SO_4^{*-} + CO_3^{2-} \rightarrow SO_4^{2-} + CO_3^{*-}$                                | $4.1 \times 10^7$                                      |                 | [69]      |
| C2.28 | $SO_4^{*-} + HCOOH(+O_2)$<br>$\rightarrow SO_4^{2-} + H^+ + HO_2^{\bullet} + CO_2$       | $2.5 \times 10^6$                                      |                 | [331]     |
|       |  |  |                 |           |
| C2.29 | $SO_4^{*-} + HCOO^- (+O_2)$<br>$\rightarrow SO_4^{2-} + HO_2^{\bullet} + CO_2$           | $2.1 \times 10^7$                                      |                 | [331]     |
|       |  |  |                 |           |
| C2.30 | $SO_4^{*-} + CH_3OH(+O_2)$<br>$\rightarrow SO_4^{2-} + H^+ + HO_2^{\bullet} + CH_3CHO$   | $9.0 \times 10^6$ ( $E_a = 18$ )                       |                 | [342]     |
|       |  |  |                 |           |
| C2.31 | $SO_4^{*-} + CH_3CH_2OH(+O_2)$<br>$\rightarrow SO_4^{2-} + H^+ + HO_2^{\bullet} + HCHO$  | $4.1 \times 10^7$ ( $E_a = 15$ )                       |                 | [342]     |
|       |  |  |                 |           |
| C2.32 | $SO_4^{*-} + CH_2(OH)_2(+O_2)$<br>$\rightarrow SO_4^{2-} + H^+ + HO_2^{\bullet} + HCOOH$ | $1.4 \times 10^7$ ( $E_a = 11$ )                       |                 | [381]     |
|       |  |  |                 |           |
| C2.33 | $SO_4^{*-} + CH_3COOH(+O_2)$<br>$\rightarrow SO_4^{2-} + H^+ + CH_3O_2 + CO_2$           | $2.0 \times 10^5$                                      |                 | [69, 331] |
|       |  |  |                 |           |

(continued)

| No.   | Elementary reaction  | k (M <sup>-1</sup> s <sup>-1</sup> );<br>(E <sub>a</sub> in kJ mol <sup>-1</sup> ) | Condition       | Reference |
|-------|--|--|-----------------|-----------|
| C2.34 | SO <sub>4</sub> <sup>•-</sup> + CH <sub>3</sub> COO <sup>-</sup> (+O <sub>2</sub> )<br>→ SO <sub>4</sub> <sup>2-</sup> + CH <sub>3</sub> O <sub>2</sub> + CO <sub>2</sub>  | 3.7 × 10 <sup>6</sup>  | 25 °C, I = 0 M  | [330]     |
|       |  | 3.9 × 10 <sup>6</sup>  | 25 °C, I = 0 M  | [340]     |
|       |  | 5.0 × 10 <sup>6</sup>  |                 | [276]     |
|       |  | 2.8 × 10 <sup>7</sup> (E <sub>a</sub> = 10)  |                 | [331]     |
| C2.35 | SO <sub>5</sub> <sup>•-</sup> + HO <sub>2</sub> <sup>•</sup> → +HSO <sub>5</sub> <sup>-</sup> + O <sub>2</sub>   | 5.5 × 10 <sup>7</sup>  |                 | [272]     |
| C2.36 | SO <sub>5</sub> <sup>•-</sup> + O <sub>2</sub> <sup>•-</sup> (+H <sub>2</sub> O) → +HSO <sub>5</sub> <sup>-</sup> + HO <sup>-</sup> + O <sub>2</sub>   | 1.7 × 10 <sup>9</sup>  |                 | [324]     |
| C2.37 | SO <sub>5</sub> <sup>•-</sup> + O <sub>2</sub> <sup>•-</sup> (+H <sup>+</sup> ) → +HSO <sub>5</sub> <sup>-</sup> + O <sub>2</sub>  | 1.9 × 10 <sup>7</sup>  |                 | [38]      |
| C2.38 | SO <sub>5</sub> <sup>•-</sup> + HSO <sub>3</sub> <sup>-</sup> → +HSO <sub>5</sub> <sup>-</sup> + SO <sub>3</sub> <sup>•-</sup><br>→ H <sup>+</sup> + SO <sub>4</sub> <sup>2-</sup> + SO <sub>4</sub> <sup>•-</sup>   | 2.3 × 10 <sup>8</sup>  |                 | [185]     |
|       |  | 2.3 × 10 <sup>7</sup>  |                 | [144]     |
| C2.39 | SO <sub>5</sub> <sup>•-</sup> + HSO <sub>3</sub> <sup>-</sup> → +HSO <sub>5</sub> <sup>-</sup> + SO <sub>3</sub> <sup>•-</sup>   | 3.6 × 10 <sup>3</sup>  |                 | [272]     |
|       |  | 8.5 × 10 <sup>3</sup>  |                 | [144]     |
|       |  | 8.6 × 10 <sup>3</sup>  |                 | [185]     |
|       |  | 2.5 × 10 <sup>4</sup>  | pH 4.9          | [327]     |
|       |  | 7.5 × 10 <sup>4</sup>  |                 | [332]     |
| C2.40 | SO <sub>5</sub> <sup>•-</sup> + SO <sub>3</sub> <sup>2-</sup> (+H <sup>+</sup> ) → +HSO <sub>5</sub> <sup>-</sup> + SO <sub>3</sub> <sup>•-</sup>  | <3.0 × 10 <sup>5</sup>   |                 | [327]     |
|       |  | 3.0 × 10 <sup>6</sup>  | pH 6.8          | [58]      |
|       |  | 1.3 × 10 <sup>7</sup>  | pH 8.7          | [327]     |
|       |  | 2.1 × 10 <sup>5</sup>  | acidic          | [185]     |
|       |  | 3.0 × 10 <sup>6</sup>  |                 | [38]      |
| C2.41 | SO <sub>5</sub> <sup>•-</sup> + SO <sub>3</sub> <sup>2-</sup> → SO <sub>5</sub> <sup>2-</sup> + SO <sub>3</sub> <sup>•-</sup>  | 3.8 × 10 <sup>6</sup>  |                 | [332]     |
| C2.42 | SO <sub>5</sub> <sup>•-</sup> + HSO <sub>3</sub> <sup>-</sup> → +HSO <sub>4</sub> <sup>-</sup> + SO <sub>4</sub> <sup>•-</sup><br>(or SO <sub>5</sub> <sup>•-</sup> + HSO <sub>3</sub> <sup>-</sup> → H <sup>+</sup> + SO <sub>4</sub> <sup>2-</sup> + SO <sub>4</sub> <sup>•-</sup> ) | 3.6 × 10 <sup>5</sup>  | pH 9            | [185]     |
|       |  | 3.6 × 10 <sup>2</sup>  |                 | [185]     |
|       |  | 2.5 × 10 <sup>4</sup>  | pH 4.9          | [332]     |
|       |  | <3.0 × 10 <sup>5</sup>   |                 | [327]     |
| C2.43 | SO <sub>5</sub> <sup>•-</sup> + SO <sub>3</sub> <sup>2-</sup> → SO <sub>4</sub> <sup>2-</sup> + SO <sub>4</sub> <sup>•-</sup>  | 1.3 × 10 <sup>7</sup>  |                 | [67]      |
|       |  | 3.0 × 10 <sup>8</sup>  |                 | [144]     |
|       |  | 1.3 × 10 <sup>5</sup>  |                 | [163]     |
| C2.44 | SO <sub>5</sub> <sup>•-</sup> + SO <sub>3</sub> <sup>2-</sup> (+H <sup>+</sup> ) → +HSO <sub>4</sub> <sup>-</sup> + SO <sub>4</sub> <sup>•-</sup>  | 1.4 × 10 <sup>5</sup>  | pH 9            | [185]     |
|       |  | 7.5 × 10 <sup>4</sup>  |                 | [327]     |
| C2.45 | SO <sub>5</sub> <sup>•-</sup> + Fe <sup>2+</sup> → FeOH <sup>2+</sup> + HSO <sub>5</sub> <sup>-</sup>  | 5.5 × 10 <sup>6</sup>  |                 | [185]     |
|       |  | 9.0 × 10 <sup>6</sup>  |                 | [332]     |
|       |  | 1.0 × 10 <sup>7</sup>  |                 | [38]      |
|       |  | 0.6 – 3 × 10 <sup>6</sup>  |                 | [343]     |
| C2.46 | HSO <sub>5</sub> <sup>-</sup> + HO <sup>•</sup> → SO <sub>5</sub> <sup>•-</sup> + H <sub>2</sub> O   | 1.7 × 10 <sup>7</sup>  | pH 7.0          | [217]     |
| C2.47 | HSO <sub>5</sub> <sup>-</sup> + Cl <sub>2</sub> <sup>•-</sup> → 2Cl <sup>-</sup> + H <sup>+</sup> + SO <sub>5</sub> <sup>•-</sup>  | <1.0 × 10 <sup>5</sup>   |                 | [54]      |
| C2.48 | SO <sub>5</sub> <sup>2-</sup> + Cl <sub>2</sub> <sup>•-</sup> → 2Cl <sup>-</sup> + SO <sub>5</sub> <sup>•-</sup>   | 1.0 × 10 <sup>8</sup>  |                 | [54]      |
| C2.49 | HSO <sub>5</sub> <sup>-</sup> + HSO <sub>3</sub> <sup>-</sup> → 2SO <sub>4</sub> <sup>2-</sup> + 2H <sup>+</sup>   | ~1 × 10 <sup>3</sup>   |                 | [144]     |
| C2.50 | HSO <sub>5</sub> <sup>-</sup> + HSO <sub>3</sub> <sup>-</sup> + H <sup>+</sup> → 2 + HSO <sub>4</sub> <sup>-</sup> + H <sup>+</sup>  | 5.6 × 10 <sup>6</sup>  |                 | [217]     |
| C2.51 | HSO <sub>3</sub> <sup>-</sup> + HSO <sub>5</sub> <sup>-</sup> → 2 + HSO <sub>4</sub> <sup>-</sup>  | 3.5 × 10 <sup>2</sup>  | pH 8.0          | [38]      |
|       |  | 9.1 × 10 <sup>3</sup>  | pH 2.9          | [217]     |
|       |  | 2.0 × 10 <sup>4</sup>  | pH 2.5          | [217]     |
|       |  | 7.9 × 10 <sup>4</sup>  | pH 1.5          | [217]     |
|       |  | 7.5 × 10 <sup>5</sup>  |                 | [12]      |
| C2.52 | HSO <sub>5</sub> <sup>-</sup> + Fe <sup>2+</sup> → FeOH <sup>2+</sup> + SO <sub>4</sub> <sup>•-</sup>  | 7.1 × 10 <sup>6</sup> (E <sub>a</sub> = 26)  | 5 °C, I = 0.2 M | [217]     |
|       |  | 1 + [H <sup>+</sup> ]10 <sup>7</sup>   |                 | [54]      |
| C2.53 | HSO <sub>5</sub> <sup>-</sup> + Δ → OH <sup>•</sup> + SO <sub>4</sub> <sup>•-</sup>  | 3 × 10 <sup>4</sup>  |                 | [343]     |
|       |  | 4.9 × 10 <sup>-9</sup> s <sup>-1</sup>   |                 | [215]     |

### C3 Rate constants for elementary reactions involving radical recombination

| No.               | Elementary reaction                                    | $k$ ( $M^{-1} s^{-1}$ );<br>( $E_a$ in $kJ mol^{-1}$ ) | Condition        | Reference  |
|-------------------|--|--|------------------|------------|
| C3.1              | $2SO_3^{\bullet-} \rightarrow S_2O_6^{2-}$             | $1.6 \times 10^8$ ( $E_a = 10.3$ )                     | I = 0 M,         | [185, 324] |
|                   |  | $2.4 \times 10^8$                                      |                  | [335]      |
|                   |  | $1.8-4.3 \times 10^8$                                  | I = 0 M          | [56, 152]  |
|                   |  | $1.8 \times 10^8$                                      | pH:4-5, T = 25°C | [56]       |
|                   |  | $4.8 \times 10^8$                                      | T = 20°C         | [269]      |
|                   |  | $5.0 \times 10^8$                                      |                  | [185]      |
| C3.2              | $2SO_3^{\bullet-} \rightarrow SO_3 + SO_3^{2-}$        | $2.3 \times 10^8$                                      | T = 25°C, pH 4.3 | [56]       |
|                   |  | $3.2 \times 10^8$                                      | I = 0 M          | [335]      |
|                   |  | $6.8 \times 10^8$                                      | pH 9.8           | [344]      |
|                   |  | $7.2 \times 10^8$                                      | pH 10.7          | [345]      |
|                   |  | $8.5 \times 10^8$                                      | pH 5.0           | [152]      |
|                   |  | $1.1 \times 10^9$                                      | pH 9.8           | [55]       |
|                   |  | $1.4 \times 10^9$                                      | pH 10.0          | [152]      |
|                   |  | $1.6 \times 10^9$                                      | pH 14.0          | [346]      |
| C3.3              | $2SO_4^{\bullet-} \rightarrow S_2O_8^{2-}$             | $1.6 \times 10^8$                                      |                  | [338]      |
|                   |  | $2.3 \times 10^8$                                      |                  | [325]      |
|                   |  | $4.1 \times 10^8$                                      | I = 0 M          | [185]      |
|                   |  | $7.0 \times 10^8$                                      |                  | [54]       |
| C3.4              | $2SO_4^{\bullet-} \rightarrow$ products                | $3.7 \times 10^8$                                      | 25°C pH 0.1-4.8  | [193]      |
|                   |  | $4.2 \times 10^8$                                      | 25°C pH 5.5      | [260]      |
| C3.5              | $2SO_5^{\bullet-} \rightarrow 2SO_4^{\bullet-} + O_2$  | $6.0 \times 10^4$                                      |                  | [144]      |
|                   |  | $7.2 \times 10^6$ ( $E_a = 22$ )                       |                  | [338]      |
|                   |  | $8.4 \times 10^6$                                      |                  | [332]      |
|                   |  | $8.7 \times 10^7$                                      |                  | [271]      |
|                   |  | $1.0 \times 10^8$                                      |                  | [330]      |
|                   |  | $2.0 \times 10^8$                                      |                  | [348]      |
|                   |  | $2.1 \times 10^8$                                      |                  | [54]       |
|                   |  | $2.2 \times 10^8$                                      |                  | [185]      |
| C3.6              | $2SO_5^{\bullet-} \rightarrow S_2O_8^{2-} + O_2^{(*)}$ | $3.0 \times 10^8$                                      |                  | [327]      |
|                   |  | $6.0 \times 10^8$                                      |                  | [349]      |
|                   |  | $1.4 \times 10^7$                                      |                  | [271]      |
|                   |  | $4.8 \times 10^7$                                      | I = 0 M          | [185]      |
|                   |  | $9.3 \times 10^7$                                      |                  | [144]      |
|                   |  | $1.3 \times 10^8$                                      |                  | [69]       |
|                   |  | $1.4 \times 10^8$                                      |                  | [349]      |
|                   |  | $1.8 \times 10^8$ ( $E_a = 22$ )                       |                  | [338]      |
| $2.2 \times 10^8$ |  | [54]   |                  |            |

**C4 Rate constants for elementary reactons involving Fe(II) oxidation**

| No.          | Elementary reaction   | k (M <sup>-1</sup> s <sup>-1</sup> );<br>(E <sub>a</sub> in kJ mol <sup>-1</sup> )            | Condition  | Reference |
|--------------|---|---|--|-----------|
| <b>C4.1</b>  | Fe <sup>2+</sup> + H <sub>2</sub> O <sub>2</sub> → Fe <sup>3+</sup> + •OH + OH <sup>-</sup>   | 5.2 × 10 <sup>1</sup> (E <sub>a</sub> = 42)   | 20 °C, 5–300 °C                                    | [263]     |
|              |   | 6.0 × 10 <sup>1</sup>   | pH 0.4–2   | [265]     |
|              |   | 6.3 × 10 <sup>1</sup>   | 25 °C, pH 4.5                                      | [264]     |
| <b>C4.2</b>  | Fe <sup>2+</sup> + •OH → Fe <sup>3+</sup> + OH <sup>-</sup>   | 2.3 × 10 <sup>8</sup>   | pH 1.0   | [350]     |
|              |   | 3.2 × 10 <sup>8</sup>   | pH 7.0   | [351]     |
|              |   | 4.3 × 10 <sup>8</sup>   |  | [351]     |
|              |   | 4.3 × 10 <sup>8</sup> (E <sub>a</sub> = 9.1)  | pH 3.0   | [99]      |
| <b>C4.3</b>  | Fe <sup>2+</sup> + •HO <sub>2</sub> + (H <sup>+</sup> ) → Fe <sup>3+</sup> + H <sub>2</sub> O <sub>2</sub>  | 1.2 × 10 <sup>6</sup> (E <sub>a</sub> = 42)   |  | [262]     |
| <b>C4.4</b>  | Fe <sup>2+</sup> + O <sub>2</sub> <sup>•-</sup> + (2H <sup>+</sup> ) → Fe <sup>3+</sup> + H <sub>2</sub> O <sub>2</sub>                           | 1.0 × 10 <sup>7</sup>   |  | [265]     |
| <b>C4.5</b>  | Fe <sup>2+</sup> + SO <sub>3</sub> <sup>•-</sup> ↔ [Fe <sup>II</sup> S <sup>V</sup> O <sub>3</sub> ] <sup>-</sup>                                 | K = 280 <sup>⊗</sup>  | pH 4   | [53]      |
| <b>C4.6</b>  | [Fe <sup>II</sup> S <sup>V</sup> O <sub>3</sub> ] <sup>-</sup> → Fe <sup>3+</sup> + SO <sub>3</sub> <sup>2-</sup>                                 | k <sub>ET</sub> = 3.1 × 10 <sup>4</sup> s <sup>-1</sup>                                       | pH 4   | [53]      |
| <b>C4.7</b>  | Fe <sup>2+</sup> + SO <sub>3</sub> <sup>•-</sup> → Fe <sup>3+</sup> + SO <sub>3</sub>   | 9.8 × 10 <sup>6</sup>   | pH 4   | [114]     |
| <b>C4.8</b>  | Fe <sup>2+</sup> + SO <sub>4</sub> <sup>•-</sup> ↔ [Fe <sup>II</sup> (S <sup>VII</sup> O <sub>4</sub> )] <sup>-</sup>                             | K = 5.3   | 20 °C, pH 3–5                                      | [52]      |
| <b>C4.9</b>  | [Fe <sup>II</sup> (S <sup>VII</sup> O <sub>4</sub> )] <sup>-</sup> → Fe <sup>III</sup> + SO <sub>4</sub> <sup>2-</sup>                            | k <sub>ET</sub> = 1.1 × 10 <sup>9</sup> s <sup>-1</sup>                                       | 20 °C, pH 3–5                                      | [52]      |
| <b>C4.10</b> | Fe <sup>2+</sup> + SO <sub>4</sub> <sup>•-</sup> → FeSO <sub>4</sub> <sup>+</sup>   | 4.0 × 10 <sup>7</sup>   | pH 2.1   | [325]     |
|              |   | 8.6 × 10 <sup>8</sup>   |  | [352]     |
|              |   | 9.9 × 10 <sup>8</sup>   |  | [353]     |
| <b>C4.11</b> | Fe <sup>2+</sup> + SO <sub>4</sub> <sup>•-</sup> → Fe <sup>3+</sup> + SO <sub>4</sub> <sup>2-</sup>   | k = 4.6 × 10 <sup>9</sup><br>(E <sub>a</sub> = -18)   | 20 °C, pH 3–5                                      | [52]      |
| <b>C4.12</b> | Fe <sup>2+</sup> + SO <sub>4</sub> <sup>•-</sup> (+H <sub>2</sub> O)  | 3.5 × 10 <sup>7</sup>   |  | [214]     |
|              | → FeOH <sup>2+</sup> + SO <sub>4</sub> <sup>2-</sup> + H <sup>+</sup>   | 4.1 × 10 <sup>7</sup>   |  | [325]     |
| <b>C4.13</b> | Fe <sup>2+</sup> + SO <sub>5</sub> <sup>•-</sup> (+H <sub>2</sub> O) → FeOH <sup>2+</sup> + HSO <sub>5</sub> <sup>-</sup>                         | 0.6–3 × 10 <sup>6</sup>   |  | [343]     |
|              |   | 4.3 × 10 <sup>7</sup>   |  | [354]     |
| <b>C4.14</b> | Fe <sup>2+</sup> + SO <sub>5</sub> <sup>•-</sup> → Fe <sup>3+</sup> + SO <sub>5</sub> <sup>2-</sup>   | 3.2 × 10 <sup>6</sup>   |  | [215]*    |
|              |   | 4.3 × 10 <sup>7</sup>   | pH 4.5   | [354]     |
| <b>C4.15</b> | Fe <sup>2+</sup> + SO <sub>5</sub> <sup>•-</sup> + H <sup>+</sup> → Fe <sup>3+</sup> + HSO <sub>5</sub> <sup>-</sup>                              | 4.3 × 10 <sup>7</sup>   |  | [354]     |
|              |   | 2.0 × 10 <sup>8</sup>   |  | [114]     |
| <b>C4.16</b> | Fe <sup>2+</sup> + HSO <sub>5</sub> <sup>-</sup> → FeOH <sup>2+</sup> + SO <sub>4</sub> <sup>•-</sup>   | 3 × 10 <sup>4</sup>   |  | [214]     |
| <b>C4.17</b> | Fe <sup>2+</sup> + HSO <sub>5</sub> <sup>-</sup> → Fe <sup>3+</sup> + SO <sub>4</sub> <sup>2-</sup> + •OH   | 3 × 10 <sup>4</sup>   |  | [355]     |
| <b>C4.18</b> | Fe <sup>2+</sup> + S <sub>2</sub> O <sub>8</sub> <sup>2-</sup> → Fe <sup>3+</sup> + SO <sub>4</sub> <sup>2-</sup> + SO <sub>4</sub> <sup>•-</sup> | (1.2 × 10 <sup>1</sup> +<br>5.5 × 10 <sup>1</sup> [H <sup>+</sup> ])<br>(E <sub>a</sub> = 62) | 30 °C, I = 1.0 M,<br>0.4 < [H <sup>+</sup> ] < 1 M | [294]     |
|              |   | 2 × 10 <sup>1</sup>   | 22 °C  | [163]     |
|              |   | 2.7 × 10 <sup>1</sup>   |  | [356]     |
|              |   | 1.0 × 10 <sup>2</sup>   |  | [141]     |
| <b>C4.19</b> | Fe <sup>2+</sup> + S <sub>2</sub> O <sub>8</sub> <sup>2-</sup> (+H <sub>2</sub> O) →  | 1.7 × 10 <sup>1</sup>   |  | [52]      |
| <b>C4.20</b> | FeOH <sup>2+</sup> + SO <sub>4</sub> <sup>2-</sup> + SO <sub>4</sub> <sup>•-</sup> + H <sup>+</sup>   |   |  |           |
| <b>C4.21</b> | Fe <sup>2+</sup> + HS <sub>2</sub> O <sub>8</sub> <sup>-</sup> → Fe <sup>3+</sup> + HSO <sub>4</sub> <sup>-</sup> + SO <sub>4</sub> <sup>•-</sup> | > 1.3 × 10 <sup>3</sup> (E <sub>a</sub> = 32)   | 35 °C, I = 1.0 M                                   | [294]     |
| <b>C4.22</b> | 2Fe <sup>2+</sup> + S <sub>2</sub> O <sub>8</sub> <sup>2-</sup> → 2Fe <sup>3+</sup> + 2SO <sub>4</sub> <sup>2-</sup>                              | 3.1 × 10 <sup>4</sup>   | pH < 0.4   | [53]      |
| <b>C4.23</b> | Fe <sup>II</sup> SO <sub>3</sub> + SO <sub>3</sub> <sup>•-</sup> → Fe <sup>3+</sup> + 2SO <sub>3</sub> <sup>2-</sup>                              | 3.2 × 10 <sup>6</sup>   |  | [304]     |

(continued)



| No.   | Elementary reaction   | $k(\text{M}^{-1} \text{s}^{-1});$<br>( $E_a$ in $\text{kJ mol}^{-1}$ ) | Condition                   | Reference |
|-------|---|--|-----------------------------|-----------|
| C4.24 | $\text{Fe}^{2+} + \text{Mn}^{3+} \rightarrow \text{Fe}^{3+} + \text{Mn}^{2+}$   | $1.5 \times 10^4$  |                             | [357]     |
| C4.25 | $\text{Fe}^{2+} + \text{Cl}_2^{\bullet-} \rightarrow 2\text{Cl}^- + \text{Fe}^{3+}$   | $1.0 \times 10^7$ ( $E_a = 25$ )                                       |                             | [358]     |
| C4.26 | $\text{Fe}^{2+} + \text{Br}_2^{\bullet-} \rightarrow 2\text{Br}^- + \text{Fe}^{3+}$   | $3.6 \times 10^6$ ( $E_a = 28$ )                                       |                             | [358]     |
| C4.27 | $\text{Fe}^{2+} + \text{CO}_3^{\bullet-} \rightarrow \text{CO}_3^{2-} + \text{Fe}^{3+}$   | Est $2 \times 10^7$  |                             | [69]      |
| C4.28 | $\text{Fe}^{2+} + \text{O}_3 \rightarrow \text{FeO}^{2+} + \text{O}_2$  | $8.2 \times 10^5$  | 25 °C, pH 0–2,<br>I = 0–1 M | [359]     |
| C4.29 | $\text{FeO}^{2+} + \text{Fe}^{2+} + (2\text{H}^+) \rightarrow 2\text{Fe}^{3+} + \text{H}_2\text{O}$   | $1.4 \times 10^5$  | 25 °C, pH 0–2,<br>I = 0–1 M | [359]     |
| C4.30 | $\text{FeO}^{2+} + (\text{H}^+) \rightarrow \text{Fe}^{3+} + \frac{1}{2}\bullet\text{OH} + \frac{1}{2}\text{OH}^-$  | $1.3 \times 10^{-2} \text{ s}^{-1}$                                    | 25 °C, pH 0–2,<br>I = 0–1 M | [359]     |
| C4.31 | $\text{FeO}^{2+} + \bullet\text{OH} \rightarrow \text{Fe}^{3+} + \text{HO}_2^{\bullet-}$  | $1.0 \times 10^7$  | 25 °C, pH 0–2,<br>I = 0–1 M | [359]     |
| C4.32 | $\text{FeO}^{2+} + \text{H}_2\text{O}_2 \rightarrow \text{Fe}^{3+} + \text{HO}_2^{\bullet} + \text{OH}^-$   | $1.0 \times 10^4$  | 25 °C, pH 0–2,<br>I = 0–1 M | [359]     |
| C4.33 | $\text{FeO}^{2+} + \text{HO}_2^{\bullet} \rightarrow \text{Fe}^{3+} + \text{HO}_2^{\bullet} + \text{OH}^-$  | $2.0 \times 10^6$  | 25 °C, pH 0–2,<br>I = 0–1 M | [359]     |
| C4.34 | $\text{Fe}^{\text{II}}\text{L} + \text{HSO}_5^- \rightarrow \text{Fe}^{\text{III}}\text{L} + \text{SO}_4^{\bullet-} + \text{OH}^-$<br>(where L = EDTA/NTA/DTPA) | $\sim 3 \times 10^4$   | 25 °C, pH $\sim 2$          | [201]     |

### C5 Rate constants for elementary reactions involving Fe(III) reduction

| No.   | Elementary reaction   | $k(\text{M}^{-1} \text{s}^{-1});$<br>( $E_a$ in $\text{kJ mol}^{-1}$ ) | Condition                   | Reference  |
|-------|---|--|-----------------------------|------------|
| C5.1  | $\text{Fe}^{3+} + \text{H}_2\text{O}_2 \rightarrow \text{Fe}^{2+} + \text{HO}_2^{\bullet} + \text{H}^+$   | $2 \times 10^{-3}$   |                             | [266, 267] |
| C5.2  | $\text{Fe}^{3+} + \text{H}_2\text{O}_2 \rightarrow \text{Fe}^{2+} + \bullet\text{OH} + \text{OH}^-$   | $7.6 \times 10^1$  |                             | [218]      |
| C5.3  | $\text{Fe}^{3+} + \text{O}_2^{\bullet-} \rightarrow \text{Fe}^{2+} + \text{O}_2$  | $1.5 \times 10^8$  |                             | [265]      |
| C5.4  | $\text{Fe}^{3+} + \text{HO}_2^{\bullet} \rightarrow \text{Fe}^{2+} + \text{O}_2 + \text{H}^+$   | $< 1.0 \times 10^4$  |                             | [265]      |
| C5.5  | $\text{Fe}^{\text{III}}\text{OH}^{2+} + \text{HO}_2^{\bullet} \rightarrow \text{Fe}^{2+} + \text{O}_2 + \text{H}_2\text{O}$                         | $1.3 \times 10^5$  |                             | [214]      |
| C5.6  | $\text{Fe}^{\text{III}}\text{OH}^{2+} + \text{O}_2^{\bullet-} \rightarrow \text{Fe}^{2+} + \text{OH}^- + \text{O}_2$                                | $1.5 \times 10^8$  |                             | [215]*     |
| C5.7  | $\text{Fe}^{\text{III}}(\text{OH})_2^+ + \text{O}_2^{\bullet-} \rightarrow \text{Fe}^{2+} + 2\text{OH}^- + \text{O}_2$                              | $1.5 \times 10^8$  |                             | [215]*     |
| C5.8  | $\text{Fe}^{\text{III}}\text{OH}^{2+} + \text{HSO}_3^- \rightarrow \text{Fe}^{2+} + \text{SO}_3^{\bullet-} + \text{H}_2\text{O}$                    | $3.9 \times 10^1$  |                             | [214]      |
| C5.9  | $\text{Fe}^{3+} + \text{SO}_3^{\bullet-} (+\text{H}_2\text{O}) \rightarrow \text{Fe}^{2+} + \text{SO}_4^{2-} + \text{H}^+$                          | $1.5 \times 10^7$  |                             | [114]      |
| C5.10 | $\text{Fe}^{\text{III}}\text{SO}_3^+ \rightarrow \text{Fe}^{2+} + \text{SO}_3^{\bullet-}$   | $2.1 \times 10^{-3} \text{ s}^{-1}$                                    | pH 2.0                      | [136]      |
|       |   | $1.4 \times 10^{-1} \text{ s}^{-1}$                                    | pH 2.5                      | [73]       |
|       |   | $1.9 \times 10^{-1} \text{ s}^{-1}$                                    | 25 °C, I = 1.0 M            | [45]       |
|       |   | $2 \times 10^{-1} \text{ s}^{-1}$                                      | pH 2.5                      | [114]      |
| C5.11 | ** $\text{Fe}^{\text{III}}\text{O} + \text{HSO}_3\text{H}^+ (+\text{O}_2) \rightarrow \text{Fe}^{2+} + \text{H}_2\text{O} + \text{SO}_5^{\bullet-}$ | $6.5 \times 10^{-2} \text{ s}^{-1}$                                    |                             | [214]      |
|       | ( $\text{Fe}^{\text{III}}\text{O} + \text{HSO}_3\text{H}^+ \rightarrow \text{Fe}^{2+} + \text{H}_2\text{O} + \text{SO}_3^{\bullet-}$ )              | $2 \times 10^{-1} \text{ s}^{-1}$                                      |                             | [141]      |
| C5.12 | $\text{Fe}^{3+} + \text{Cu}^+ \rightarrow \text{Fe}^{2+} + \text{Cu}^{2+}$  | $3 \times 10^7$  |                             | [360]      |
| C5.13 | $[\text{HOFe}^{\text{III}}\text{OS}^{\text{IV}}\text{O}_2] \leftrightarrow [\text{HOFe}^{\text{II}}\text{OS}^{\text{V}}\text{O}_2]$                 | $4 \times 10^{-2} \text{ s}^{-1}$                                      | 25 °C, I = 0.4 M,<br>pH 2.1 | [136]      |

\*Quoted in Yermakov *et al.* 2003 [215], but original source unclear.

\*\*Expression in Yermakov *et al.* 2003 [215] as  $\text{Fe}^{\text{III}}\text{OHSO}_3\text{H}^+ (+\text{O}_2) \rightarrow \text{Fe}^{2+} + \text{H}_2\text{O} + \text{SO}_5^{\bullet-}$ , with rate given in unit  $\text{s}^{-1}$ . If molecular oxygen is required in the decay, then  $0.2 \text{ s}^{-1}$  represent the rate constant at  $\text{O}_2$ -abundant condition. It is possible that the complex first decomposes to give  $\text{SO}_3^{\bullet-}$ , which then reacts with  $\text{O}_2$  to give  $\text{SO}_5^{\bullet-}$ .

**C6 Rate constants for elementary photolysis reactions**

| No.   | Elementary reaction   | k(s <sup>-1</sup> )    | Reference |
|-------|---|------------------------|-----------|
| C6.1  | Fe <sup>III</sup> OH <sup>2+</sup> + hv → Fe <sup>2+</sup> + •OH                                      | 4.5 × 10 <sup>-3</sup> | [254]     |
| C6.2  | Fe <sup>III</sup> (OH) <sub>2</sub> <sup>+</sup> + hv → Fe <sup>2+</sup> + OH <sup>-</sup> + •OH      | 5.8 × 10 <sup>-3</sup> | [361]     |
| C6.3  | Fe <sup>III</sup> SO <sub>4</sub> <sup>+</sup> + hv → Fe <sup>2+</sup> + SO <sub>4</sub> <sup>-</sup> | 6.4 × 10 <sup>-3</sup> | [254]     |
| C6.4  | HSO <sub>3</sub> <sup>-</sup> + hv → H <sup>+</sup> + SO <sub>3</sub> <sup>•-</sup>                   | 2.9 × 10 <sup>-5</sup> | [144]     |
| C6.5  | SO <sub>3</sub> <sup>2-</sup> + hv → SO <sub>3</sub> <sup>•-</sup> + e <sub>aq</sub> <sup>-</sup>     | 6.0 × 10 <sup>-5</sup> | [144]     |
| C6.6  | SO <sub>4</sub> <sup>2-</sup> + hv(λ <sub>exc</sub> < 200 nm) → SO <sub>4</sub> <sup>•-</sup>         | –                      | [260]     |
| C6.7  | H <sub>2</sub> O <sub>2</sub> + hv → 2•OH   | 7.2 × 10 <sup>-6</sup> | [362]     |
| C6.8  | NO <sub>2</sub> <sup>-</sup> + hv(+H <sup>+</sup> ) → NO + •OH  | 2.6 × 10 <sup>-5</sup> | [362]     |
| C6.9  | NO <sub>2</sub> <sup>-</sup> + hv(+H <sub>2</sub> O) → NO + •OH + OH <sup>-</sup>                     | 2.6 × 10 <sup>-5</sup> | [215]*    |
| C6.10 | NO <sub>3</sub> <sup>-</sup> + hv(+H <sup>+</sup> ) → NO <sub>2</sub> + •OH                           | 4.3 × 10 <sup>-7</sup> | [362]     |
| C6.11 | NO <sub>3</sub> <sup>-</sup> + hv(+H <sub>2</sub> O) → NO <sub>2</sub> + •OH + OH <sup>-</sup>        | 5.6 × 10 <sup>-5</sup> | [215]*    |

\*Quoted in Yermakov *et al.* 2003 [215], but original source unclear.

**C7 Rate constants for other elementary reactions related to aque. Fe-S(IV)-O<sub>2</sub> system**

| No.   | Elementary reaction   | k(M <sup>-1</sup> s <sup>-1</sup> );<br>(E <sub>a</sub> in kJ mol <sup>-1</sup> ) | Condition                   | Reference |
|-------|---|---|-----------------------------|-----------|
| C7.1  | H• + O <sub>2</sub> → HO <sub>2</sub> <sup>•</sup>  | 7.5 × 10 <sup>9</sup>   |                             | [144]     |
|       |   | 2 × 10 <sup>10</sup>  |                             | [296]     |
|       |   | 2.1 × 10 <sup>10</sup>  |                             | [261]     |
| C7.2  | O <sub>2</sub> <sup>•-</sup> + H <sup>+</sup> → HO <sub>2</sub> <sup>•</sup>  | 5.0 × 10 <sup>10</sup>  |                             | [296]     |
| C7.3  | O <sub>2</sub> <sup>•-</sup> + O <sub>3</sub> (+H <sup>+</sup> ) → 2O <sub>2</sub> + •OH  | 1.5 × 10 <sup>9</sup>   |                             | [363]     |
| C7.4  | O <sub>2</sub> <sup>•-</sup> + •OH → O <sub>2</sub> + OH <sup>-</sup>   | 1.1 × 10 <sup>10</sup> (E <sub>a</sub> = 18)                                      |                             | [364]     |
| C7.5  | O <sub>2</sub> <sup>•-</sup> → products   | 1.9 × 10 <sup>2</sup> s <sup>-1</sup>   |                             | [185]     |
| C7.6  | HO <sub>2</sub> <sup>•</sup> + OH• → H <sub>2</sub> O + O <sub>2</sub>  | 1.0 × 10 <sup>10</sup>  |                             | [365]     |
| C7.7  | HO <sub>2</sub> <sup>•</sup> + HO <sub>2</sub> <sup>•</sup> → H <sub>2</sub> O <sub>2</sub> + O <sub>2</sub>                        | 8.3 × 10 <sup>5</sup> (E <sub>a</sub> = 23)                                       |                             | [296]     |
| C7.8  | HO <sub>2</sub> <sup>•</sup> + O <sub>2</sub> <sup>•-</sup> (+H <sup>+</sup> ) → H <sub>2</sub> O <sub>2</sub> + O <sub>2</sub>     | 9.7 × 10 <sup>8</sup>   |                             | [144]     |
| C7.9  | HO <sub>2</sub> <sup>•</sup> + O <sub>2</sub> + H <sub>2</sub> O → H <sub>2</sub> O <sub>2</sub> + O <sub>2</sub> + OH <sup>-</sup> | 9.7 × 10 <sup>7</sup> (E <sub>a</sub> = 8.8)                                      |                             | [296]     |
| C7.10 | HO <sub>2</sub> <sup>•</sup> → H <sup>+</sup> + O <sub>2</sub> <sup>•-</sup>  | 6.5 × 10 <sup>5</sup> s <sup>-1</sup>   |                             | [296]     |
| C7.11 | HO <sub>3</sub> <sup>•</sup> → •OH + O <sub>2</sub>   | 1.1 × 10 <sup>5</sup>   |                             | [299]     |
| C7.12 | •OH + HSO <sub>4</sub> <sup>-</sup> → H <sub>2</sub> O + SO <sub>4</sub> <sup>•-</sup>  | 3.5 × 10 <sup>5</sup>   |                             | [366]     |
| C7.13 | •OH + HSO <sub>5</sub> <sup>-</sup> → H <sub>2</sub> O + SO <sub>5</sub> <sup>•-</sup>  | 5.0 × 10 <sup>6</sup>   |                             | [54]      |
| C7.14 | •OH + SO <sub>5</sub> <sup>2-</sup> → OH <sup>-</sup> + SO <sub>5</sub> <sup>•-</sup>   | 2.1 × 10 <sup>9</sup>   |                             | [367]     |
| C7.15 | •OH + S <sub>2</sub> O <sub>8</sub> <sup>2-</sup> → OH <sup>-</sup> + S <sub>2</sub> O <sub>8</sub> <sup>•-</sup>                   | 1.2 × 10 <sup>7</sup>   |                             | [54]      |
| C7.16 | O <sub>3</sub> <sup>-</sup> + H <sup>+</sup> → HO <sub>3</sub> <sup>•</sup>   | 5.5 × 10 <sup>10</sup>  |                             | [299]     |
| C7.17 | O <sub>3</sub> <sup>-</sup> + H <sub>2</sub> O → HO <sub>3</sub> <sup>•</sup> + OH <sup>-</sup>                                     | 8.5 × 10 <sup>9</sup>   |                             | [299]     |
| C7.18 | H <sub>2</sub> O <sub>2</sub> + •OH → H <sub>2</sub> O + HO <sub>2</sub> <sup>•</sup>   | 2.7 × 10 <sup>7</sup> (E <sub>a</sub> = 14)                                       | 25 °C, pH 7–14              | [368]     |
| C7.19 | S <sub>2</sub> O <sub>7</sub> <sup>2-</sup> + H <sub>2</sub> O → 2SO <sub>4</sub> <sup>2-</sup> + 2H <sup>+</sup>                   | 1.3 × 10 <sup>-2</sup>  | 25 °C, pH 2–5,<br>I = 0.5 M | [216]     |
|       |   |   |                             |           |
| C7.20 | S <sub>2</sub> O <sub>8</sub> <sup>2-</sup> (+H <sub>2</sub> O) → 2SO <sub>4</sub> <sup>•-</sup>                                    | 1.1 × 10 <sup>-8</sup> s <sup>-1</sup>  |                             | [178]     |
|       |   | 1.0 × 10 <sup>-7</sup> s <sup>-1</sup>  | 25 °C, pH 1.3               | [274]     |
|       |   | 5.7 × 10 <sup>-5</sup> s <sup>-1</sup>  | 70 °C, pH 1.3               | [274]     |

(continued)

| No.          | Elementary reaction   | $k(\text{M}^{-1}\text{s}^{-1});$<br>( $E_a$ in $\text{kJ mol}^{-1}$ ) | Condition | Reference |
|--------------|---|---|-----------|-----------|
| <b>C7.21</b> | $\text{S}_2\text{O}_8^{2-} + \text{Ag}^+ \rightarrow 2\text{SO}_4^{\bullet-} + \text{Ag}^+$     | $3.3 \times 10^{-3} - 2.2 \times 10^{-2}$                             | 25 °C     | [274]     |
| <b>C7.22</b> | $\text{Cl}^\bullet + \text{Cl}^- \rightarrow \text{Cl}_2^{\bullet-}$                            | $2.1 \times 10^{10}$  |           | [262]     |
| <b>C7.23</b> | $2\text{NO}_2 + \text{H}_2\text{O} \rightarrow \text{HNO}_3 + \text{HNO}_2$                     | $7.4 \times 10^7$   | 25 °C     | [333]     |
|              |   | $1.6 \times 10^7$   | 55 °C     | [12]      |
| <b>C7.24</b> | $e_{\text{aq}}^- + \text{O}_2 \rightarrow \text{O}_2^{\bullet-}$                                | $1.9 \times 10^{10}$  |           | [261]     |
|              |   | $2.0 \times 10^{10}$  |           | [296]     |
| <b>C7.25</b> | $e_{\text{aq}}^- + \text{N}_2\text{O} \rightarrow \text{N}_2 + \text{OH}^\bullet + \text{OH}^-$ | $9.1 \times 10^9$   |           | [261]     |
| <b>C7.26</b> | $e_{\text{aq}}^- + \text{H}^+ \rightarrow \text{H}^\bullet$                                     | $2.3 \times 10^{10}$  |           | [261]     |

\*Quoted in Yermakov *et al.* 2003 [215], but original source unclear.

### C8 Forward ( $k_{\text{for}}$ ) and backward ( $k_{\text{bk}}$ ) rate constants for selected reactions at 25 °C\*

| No.          | Reaction   | $k_{\text{for}}(\text{s}^{-1})$<br>( $E_a$ in $\text{kJ mol}^{-1}$ ) | $k_{\text{bk}}(\text{M}^{-1}\text{s}^{-1})$ | $\log K^{**}$     | $\log K_{\text{Lit}}^c$ |
|--------------|--|--|---|-------------------|-------------------------|
| <b>C8.1</b>  | $\text{H}_2\text{O} \leftrightarrow \text{H}^+ + \text{OH}^-$  | $2.3 \times 10^{-5}$ ( $E_a = 57$ ) [369]                            | $1.3 \times 10^{11}$ [370]                  | -15.7             | -14.0 [292]             |
| <b>C8.2</b>  | $2\text{Fe}^{3+} (+2\text{H}_2\text{O}) \leftrightarrow \text{Fe}_2(\text{OH})_2^{4+} + 2\text{H}^+$ | $3.6 \times 10^{-3a}$ [138]  | $6.7 \times 10^{3b}$ [138]                  | -6.3              | -2.9                    |
| <b>C8.3</b>  | $\text{Fe}^{3+} (+2\text{H}_2\text{O}) \leftrightarrow \text{Fe}(\text{OH})_2^+ + 2\text{H}^+$       | $3.5 \times 10^0$ [138]  | $2.5 \times 10^0$ [138]                     | 1.5               | -5.8                    |
| <b>C8.4</b>  | $\text{Fe}_2(\text{OH})\text{SO}_4^{3+} \leftrightarrow \text{FeOH}^{2+} + \text{FeSO}_4^+$          | $4.6 \times 10^0$ [47]   | $2.0 \times 10^2$ [47]                      | -1.6              | - <sup>c</sup>          |
| <b>C8.5</b>  | $\text{HSO}_5^- \leftrightarrow \text{H}^+ + \text{SO}_5^{2-}$                                       | $2.0 \times 10^1$ [185, 371]   | $5 \times 10^{10}$ [371]                    | -9.4              | -9.6                    |
| <b>C8.6</b>  | $2\text{HSO}_3^- \leftrightarrow \text{S}_2\text{O}_5^{2-} + \text{H}_2\text{O}$                     | $7 \times 10^{2a}$ [96]  | $1 \times 10^{4b}$ [96]                     | -1.2              | -1.2                    |
| <b>C8.7</b>  | $\text{FeOH}^{2+} + \text{H}_2\text{O} \leftrightarrow \text{Fe}(\text{OH})_2^+ + \text{H}^+$        | $1.1 \times 10^{3a}$ [372]   | $8.0 \times 10^9$ [372]                     | -6.9              | -3.6 <sup>d</sup>       |
|              |  | $6.1 \times 10^{4a}$ [372]   |   | -5.1              |                         |
|              |  | $5.6 \times 10^{5a}$ [215]   |   | -4.2              |                         |
| <b>C8.8</b>  | $\text{HSO}_3^- \leftrightarrow \text{H}^+ + \text{SO}_3^{2-}$                                       | $3.1 \times 10^3$ ( $E_a = -16$ ) [373]                              | $5 \times 10^{10}$ [370]                    | -7.2              | -7.2                    |
| <b>C8.9</b>  | $\text{Fe}^{3+} + \text{SO}_4^{2-} \leftrightarrow \text{FeSO}_4^+$                                  | (I~0.5 M) $4.7 \times 10^{3a}$ [26]                                  | $1.8 \times 10^{5b}$ [26]                   | -1.6              | 4.2 <sup>d</sup>        |
| <b>C8.10</b> | $\text{Fe}^{3+} + \text{H}_2\text{O} \leftrightarrow \text{FeOH}^{2+} + \text{H}^+$                  | $4.7 \times 10^{4a}$ [26]  | $4.3 \times 10^8$ [26]                      | -4.0              | -2.2 <sup>d</sup>       |
| <b>C8.11</b> | $\text{SO}_2 + \text{H}_2\text{O} \leftrightarrow \text{H}^+ + \text{HSO}_3^-$                       | $6.3 \times 10^{4a}$ ( $E_a = -16$ ) [373]                           | $2.0 \times 10^8$ [370]                     | -3.5              | -1.9                    |
|              |  | $1.0 \times 10^{8a}$ [374]   | $2.5 \times 10^9$ [374]                     | -1.4 <sup>f</sup> |                         |
| <b>C8.12</b> | $\text{Fe}^{3+} + \text{H}_2\text{O} \leftrightarrow \text{FeOH}^{2+} + \text{H}^+$                  | $8.6 \times 10^{5a}$ [215]   | $4.3 \times 10^8$ [215]                     | -2.7              | -2.2                    |
|              |  |  | $1.5 \times 10^9$ [99]                      | -3.2              |                         |
|              |  | $3.5 \times 10^{-1a}$ [138]  | $1.3 \times 10^2$ [138]                     | -2.6              |                         |
| <b>C8.13</b> | $\text{CH}_3\text{COOH} \leftrightarrow \text{H}^+ + \text{CH}_3\text{COO}^-$                        | $8.8 \times 10^5$ ( $E_a = 0$ ) [369]                                | $5 \times 10^{10}$ [370]                    | -4.8              | -4.8                    |
| <b>C8.14</b> | $\text{Fe}^{3+} + \text{SO}_4^{2-} \leftrightarrow \text{FeSO}_4^+$                                  | $3.2 \times 10^{7a}$ [215]   | $1.8 \times 10^{5b}$ [215]                  | 2.3               | 4.2                     |
| <b>C8.15</b> | $\text{HSO}_4^- \leftrightarrow \text{H}^+ + \text{SO}_4^{2-}$                                       | $1.0 \times 10^9$ ( $E_a = -22$ ) [375]                              | $1 \times 10^{11}$ [370]                    | -2.0              | -2.0                    |
| <b>C8.16</b> | $\text{Fe}^{3+} + \text{HSO}_3^- \leftrightarrow \text{FeHSO}_3^{2+}$                                | $5.0 \times 10^{10a}$ [215]  | $6.9 \times 10^{8b}$ [215]                  | 1.9               | 1.8                     |
| <b>C8.17</b> | $\text{FeOH}^{2+} + \text{HSO}_3^- \leftrightarrow \text{FeOHSO}_3\text{H}^+$                        | $5.0 \times 10^{10a}$ [215]  | $8.3 \times 10^{7b}$ [215]                  | 2.8               | 2.8                     |
| <b>C8.18</b> | $\text{Fe}^{3+} + \text{SO}_3^{2-} \leftrightarrow \text{FeSO}_3^+$                                  | $5.0 \times 10^{10a}$ [215]  | $6.9 \times 10^{3b}$ [215]                  | 6.9               | 2.0                     |

(continued)

| No.          | Reaction  | $k_{\text{for}}(\text{s}^{-1})$<br>( $E_a$ in $\text{kJ mol}^{-1}$ ) | $k_{\text{bk}}(\text{M}^{-1}\text{s}^{-1})$ | $\log K^{**}$ | $\log K_{\text{Lit}}^c$ |
|--------------|---|--|---|---------------|-------------------------|
| <b>C8.19</b> | $\text{FeOH}^{2+} + \text{SO}_3^{2-} \leftrightarrow \text{FeOHSO}_3$ | $5.0 \times 10^{10a}$ [215]  | $2.5 \times 10^{3b}$ [215]                  | 7.3           | 8.6                     |
| <b>C8.20</b> | $\text{HNO}_3 \leftrightarrow \text{H}^+ + \text{NO}_3^-$             | $1.1 \times 10^{12}(E_a = -15)$ [375]                                | $5 \times 10^{10}$ [370]                    | 1.3           | 1.4                     |
| <b>C8.21</b> | $\text{H}_2\text{SO}_4 \leftrightarrow \text{H}^+ + \text{HSO}_4^-$   | $5.0 \times 10^{12}$ [215]   | $5.0 \times 10^{10}$ [215]                  | 2.0           | - <sup>e</sup>          |
| <b>C8.22</b> | $\text{Fe}^{2+} + \text{SO}_4^{2-} \leftrightarrow \text{FeSO}_4$     | $7.9 \times 10^{12a}$ [215]  | $5.0 \times 10^{10b}$ [215]                 | 2.2           | 2.3                     |
| <b>C8.23</b> | $\text{HCl} \leftrightarrow \text{H}^+ + \text{Cl}^-$                 | $8.6 \times 10^{16}(E_a = -57)$ [376]                                | $5 \times 10^{10}$ [370]                    | -6.2          | -6.2 [376]              |

\*Original reference unclear for rate constants quoted from Yermakov *et al.* 2003 [215].

\*\*Where  $K = k_{\text{for}}/k_{\text{bk}}$ .

<sup>a</sup>Second order  $k_{\text{for}}$  in unit  $\text{M}^{-1}\text{s}^{-1}$ .

<sup>b</sup>First order  $k_{\text{bk}}$  in unit  $\text{s}^{-1}$ .

<sup>c</sup> $K_{\text{Lit}} = K_{\text{eqm}}$  reported in literature. Values from **B1**, **B2**, **B3**, and **B5**.

<sup>d</sup>Calculated from average of the values reported in **B3** and **B5** and acid dissociation constant for H<sub>2</sub>O.

<sup>e</sup>Not found.

<sup>f</sup>At ionic strength of 0.9 M.

### C9 Rate expression for catalytic and non-catalytic oxidation of S(IV) and Fe(II)

| Rate expression*   | Condition                           | Reference |
|--|-------------------------------------|-----------|
| <b>Non-catalytic S(IV) oxidation</b>   |                                     |           |
| $r_{\text{S(IV)}} = 2r_{\text{O}_2} = 2k[\text{HSO}_3^-]^2[\text{H}^+]^{-2}$<br>$k = 3.6 \times 10^6 \text{ s}^{-1}$   | 25 °C, I = 0.05 M, pH ~4-6          | [216]     |
| $r_{\text{S(IV)}} = k[\text{S}^{\text{IV}}]$<br>$k = 4.5 \times 10^{-5} \text{ s}^{-1}$  | 30 °C, I = 0.1-1.0 M                | [377]     |
| $r_{\text{S(IV)}} = k_1[\text{S(IV)}]^2[\text{O}_2]^{1/2}$<br>$\ln k_1 = 19.5 - 5070/T + 14.71T^{1/2} - 2.9I - 2880I^{1/2};$<br>( $k_1$ in $\text{M}^{-1.5} \text{ min}^{-1}$ ); $E_a = 140 \text{ kJ mol}^{-1}$ | 15-45 °C, pH 4-8.5, salinity ~3.5%  | [164]     |
| $r_{\text{S(IV)}} = k[\text{S(IV)}][\text{H}^+]^{-0.7}$<br>$k = 1.2 \times 10^{-5} \text{ M}^{0.7} \text{ s}^{-1}$ ; $E_a = 30 \text{ kJ mol}^{-1}$  | 10-30 °C, pH 2-6<br>seawater        | [283]     |
| <b>Non-catalytic Fe(II) oxidation</b>  |                                     |           |
| $r_{\text{Fe(II)}} = k_1[\text{Fe}^{2+}][\text{OH}^-]^2\text{P}_{\text{O}_2}$  | 25 °C, pH > 4.5                     | [378]     |
| $r_{\text{Fe(II)}} = k_2[\text{Fe}^{2+}]\text{P}_{\text{O}_2}$<br>$k_1 = 1.3 \times 10^{12} \text{ M}^{-2} \text{ atm}^{-1} \text{ s}^{-1}$<br>$k_2 = 1.7 \times 10^{-9} \text{ atm}^{-1} \text{ s}^{-1}$        | 25 °C, pH < 4.5                     |           |
| $r_{\text{Fe(II)}} = k_1[\text{Fe(II)}][\text{O}_2][\text{OH}^-]^2$<br>$\ln k_1 = 21.6 - 1550/T + 3.3I^{1/2} - 1.5I$<br>( $k_1$ in $\text{M}^{-3} \text{ min}^{-1}$ ); $E_a = 29 \text{ kJ mol}^{-1}$            | 5-45 °C, pH 5-9,<br>salinity 0-3.5% | [158]     |
| <b>Catalytic S(IV) oxidation</b>   |                                     |           |
| $r_{\text{S(IV)}} = 6[\text{Fe}^{\text{III}}][\text{S}^{\text{IV}}]/[\text{H}^+]$ *  | 25 °C, pH 0-3                       | [67]      |
| $r_{\text{S(IV)}} = 10^9[\text{Fe}^{\text{III}}]^2[\text{S}^{\text{IV}}]$ *  | 25 °C, pH 4                         |           |
| $r_{\text{S(IV)}} = 10^{-3}[\text{S}^{\text{IV}}]$ *   | 25 °C, pH 5-6                       |           |

(continued)

| Rate expression*   | Condition                                    | Reference          |
|--|--|--------------------|
| $r_{S(IV)} = 10^{-4}[S^{IV}]^*$  | 25 °C, pH 7                                  |                    |
| $r_{S(IV)} = (k_1 + k_2[H^+]^{0.5} + k_3P_{O_2}[H^+]^{-1})[SO_3^{2-}]$                 | 25 °C, pH 4–12, $P_{O_2}$ 0.11–1.0 atm       | [379]              |
| $k_1 = 4.4 \times 10^{-3} s^{-1}$  |  |                    |
| $k_2 = 8.9 M^{-0.5} s^{-1}$  |  |                    |
| $k_3 = 3.9 \times 10^{-12} Matm^{-1} s^{-1}$   |  |                    |
| $r_{S(IV)} = k[Fe(III)][S(IV)][H^+]^{-1}$  | 25 °C, pH 0–3                                | [64]               |
| $k = 8.2 \times 10^{-1} s^{-1}$  |  |                    |
| $r_{S(IV)} = k[Fe(III)][S(IV)][H^+]^{-1}$  | 20 °C, pH 4–5                                | [282] <sup>a</sup> |
| $k = 1.0 \times 10^{-1} s^{-1}$  |  | [136]              |
| $r_{S(IV)} = k[Fe(III)][S(IV)][H^+]^{-1}$  | 20 °C, pH $\leq$ 4                           | [146] <sup>a</sup> |
| $k = 7.6 \times 10^{-2} s^{-1}$  |  | [136]              |
| $r_{S(IV)} = k[Fe(III)][SO_3^{2-}]$  | 20 °C, pH 1.3–3.3                            | [145] <sup>a</sup> |
| $k = 4.5 \times 10^5 M^{-1} s^{-1}$  |  | [136]              |
| $r_{S(IV)} = k[Fe(III)][S(IV)]^2[H^+]^{-1}$  | 10 °C, pH 1.5–3.0                            | [380] <sup>a</sup> |
| $k = 4.0 \times 10^1 M^{-1} s^{-1}$  |  | [136]              |
| $r_{S(IV)} = k[Fe(III)][S(IV)]^2$  | 20 °C, pH $\geq$ 6                           | [146] <sup>a</sup> |
| $k = 1.0 \times 10^5 M^{-2} s^{-1}$  |  | [136]              |
| $r_{S(IV)} = k[Fe(III)][S(IV)]^2$  | 20 °C, pH $\geq$ 5                           | [282] <sup>a</sup> |
| $k = 1.0 \times 10^7 M^{-2} s^{-1}$  |  | [136]              |
| $r_{S(IV)} = k[Fe^{3+}][S(IV)]$  | pH 4–8                                       | [282]              |
| $k = 1.0 \times 10^2 M^{-1} s^{-1}$  |  |                    |
| $r_{S(IV)} = k\alpha[Fe(III)][S(IV)]^2$  | Compilation of all <sup>a</sup> studies      | [136]              |
| $k = 1.0\text{--}1.2 \times 10^6 M^{-1} s^{-1}$  |  |                    |
| $\alpha = K_{a1}K_{a2}/([H^+]^2 + K_{a1}[H^+] + K_{a1}K_{a2})$                         |  |                    |
| $-\log K_{a1} = 1.9$   |  |                    |
| $-\log K_{a2} = 7.2$   |  |                    |
| $r_{S(IV)} = k_1[Fe(II)]_0^{1.2}[HSO_3^-]^{0.6}[H^+]^{-1.1}[SO_4^{2-}]^{-0.4}$         | 25 °C, pH $\sim$ 0.7–2.3, $P_{O_2} < 10$ bar | [98]               |
| $\log k_1 = 0.8 - 11^{1/2}[1 + I^{1/2}]^{-1}$  |  |                    |
| $r_{S(IV)} = k[Fe^{3+}][HSO_3^-]^2[H^+]^{-1}$  |  | [219]              |
| $k = 2.6 \times 10^2 M^{-1} s^{-1}$  |  |                    |
| <b>Catalytic Fe(II) oxidation</b>  |  |                    |
| $r_{Fe(II)} = k[S(IV)]^{1.40}[O_2]^{0.314}([Fe_T]/[SO_4^{2-}])^{1.06}/[H^+]_i^{0.062}$ | 25 °C  | [74]               |
| $r_{Fe(II)} = k[Fe^{2+}]^a[O_2]^b/[H_2SO_4]^c$   | 65–80 °C, 2% SO <sub>2</sub>                 | [115]              |
| {a $\sim$ 2, b $\sim$ 1, c $\sim$ 0.25–0.35}   |  |                    |
| $r_{Fe(II)} = k[Fe(III)][HSO_3^-]/[H^+]^{0.2}$   | 40–95 °C, 2% SO <sub>2</sub> ,<br>pH: 0–3    | [39]               |
| <b>Fe(III) reduction</b>   |  |                    |
| $r_{Fe(III)} = 0.004[Fe(III)][S(IV)][H^+]^{-2}(1 + 20[Fe^{2+}])$                       | 25 °C, I = 1.0 M                             | [119]              |

\*For atmospheric waters. Effects due to ionic strength, high S(IV), or the presence of organics can be empirically corrected. See Martin *et al.* 1991 [67], Kotronarou *et al.* 1993 [181].

## Appendix D: Molecular structures of oxysulphur anions and radicals

## D1 Structures of oxysulphur anions

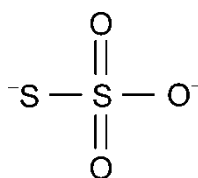
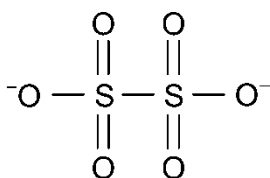
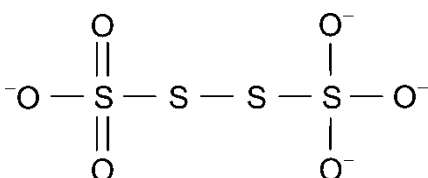
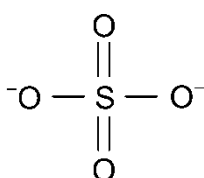
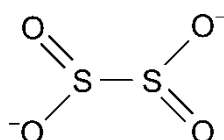
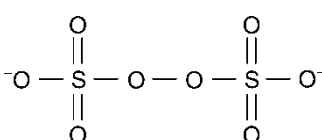
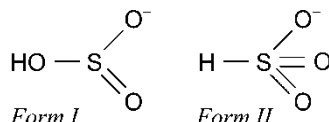
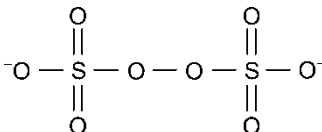
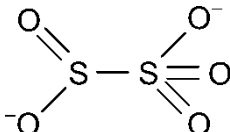
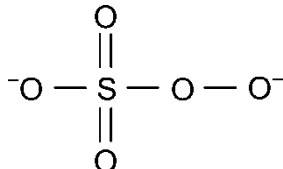
| Oxidation state <sup>a</sup> | Molecular configuration  | Oxidation state      | Molecular configuration  |
|------------------------------|--|----------------------|--|
| S(II)                        |  <p>Thiosulphate (S<sub>2</sub>O<sub>3</sub><sup>2-</sup>)<sup>c</sup></p>  | S(V) <sup>b</sup>    |  <p>Dithionate (S<sub>2</sub>O<sub>6</sub><sup>2-</sup>)</p>                     |
| S(II)                        |  <p>Tetrathionate (S<sub>4</sub>O<sub>6</sub><sup>4-</sup>)<sup>c</sup></p> | S(VI) <sup>b</sup>   |  <p>Sulphate (SO<sub>4</sub><sup>2-</sup>)</p>                                   |
| S(III) <sup>b</sup>          |  <p>Dithionite/Hyposulphite (S<sub>2</sub>O<sub>4</sub><sup>2-</sup>)</p>  | S(VI) <sup>b</sup>   |  <p>Pyrosulphate (S<sub>2</sub>O<sub>7</sub><sup>2-</sup>)<sup>f</sup></p>      |
| S(IV) <sup>b</sup>           |  <p>Bisulphite (HSO<sub>3</sub><sup>-</sup>)<sup>d</sup></p>              | S(VII) <sup>b</sup>  |  <p>Peroxydisulphate (S<sub>2</sub>O<sub>8</sub><sup>2-</sup>)<sup>g</sup></p> |
| S(IV) <sup>b</sup>           |  <p>Disulphite (S<sub>2</sub>O<sub>5</sub><sup>2-</sup>)<sup>e</sup></p>  | S(VIII) <sup>b</sup> |  <p>Peroxymonosulphate (SO<sub>5</sub><sup>2-</sup>)<sup>g</sup></p>           |

<sup>a</sup>Average oxidation state of sulphur atom.<sup>b</sup>One of the several resonance stabilized configurations.<sup>c</sup>Hypothesized structure based upon sulphur divalence and tetravalence. See the review on sulphur valence by Benson (1978) [382].<sup>d</sup>Brandt and van Eldik (1995) [26].<sup>e</sup>Brandt and van Eldik (1995) [26], Conklin and Hoffmann. (1988a) [44].<sup>f</sup>Betterton and Hoffmann. (1988) [217], Connick *et al.* (1993) [216].<sup>g</sup>Dogliotti *et al.* (1967) [193], Betterton and Hoffmann. (1988) [217].

## D2 Structures of oxysulphur radicals\*

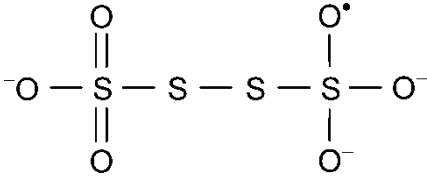
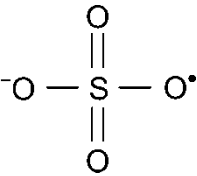
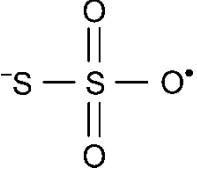
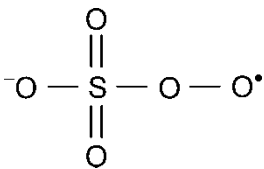
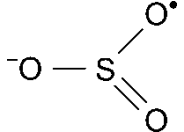
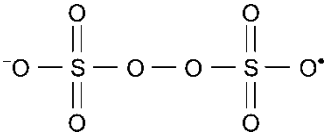
| Oxidation state <sup>a</sup> | Molecular configuration   | Oxidation state | Molecular configuration   |
|------------------------------|---|-----------------|---|
| S(IX/IV)                     |  <p>Tetrathionate radical (<math>S_4O_6^{3-}</math>)<sup>c</sup></p> | S(VII)          |  <p>Sulphate radical (<math>SO_4^{\bullet-}</math>)</p>           |
| S(V/II)                      |  <p>Thiosulphate radical (<math>S_2O_3^{3-}</math>)<sup>b</sup></p>  | S(IX)           |  <p>Peroxymonosulphate radical (<math>SO_5^{\bullet-}</math>)</p> |
| S(V)                         |  <p>Sulphite radical (<math>SO_3^{\bullet-}</math>)</p>              | S(XV/II)        |  <p>Peroxydisulphate radical (<math>S_2O_8^{3-}</math>)</p>       |

\*For convenience, the unpaired electron is drawn on the oxygen atom. In reality, the unpaired electron should reside on the S atom, stabilised by the resonance of electron densities from adjacent oxygen atoms.

<sup>a</sup>Averaged oxidation state of sulphur atom.

<sup>b</sup>Based on hypothesized structure.

<sup>c</sup>Postulated by Das *et al.* (1999) [57] in accordance to spectroscopic observation. A further rearrangement with an oxygen bridging into the sulphur backbone as suggested by the paper is not shown.